



# NONRESIDENT TRAINING COURSE



February 1992

---

# Fireman

NAVEDTRA 14104

**Although the words “he,” “him,” and “his” are used sparingly in this course to enhance communication, they are not intended to be gender driven or to affront or discriminate against anyone.**

## PREFACE

By enrolling in this self-study course, you have demonstrated a desire to improve yourself and the Navy. Remember, however, this self-study course is only one part of the total Navy training program. Practical experience, schools, selected reading, and your desire to succeed are also necessary to successfully round out a fully meaningful training program.

**COURSE OVERVIEW:** By successfully completing this nonresident training course, you will demonstrate mastery of the following subject areas: engineering administration, and engineering fundamentals, the basic steam cycle, boilers, steam turbines, gas turbines, internal-combustion engines, ship propulsion, auxiliary machinery and equipment, instruments, shipboard electrical equipment, and environmental controls.

**THE COURSE:** This self-study course is organized into subject matter areas, each containing learning objectives to help you determine what you should learn along with text and illustrations to help you understand the information. The subject matter reflects day-to-day requirements and experiences of personnel in the rating or skill area. It also reflects guidance provided by Enlisted Community Managers (ECMs) and other senior personnel, technical references, instructions, etc., and either the occupational or naval standards, which are listed in the *Manual of Navy Enlisted Manpower Personnel Classifications and Occupational Standards*, NAVPERS 18068.

**THE QUESTIONS:** The questions that appear in this course are designed to help you understand the material in the text.

**VALUE:** In completing this course, you will improve your military and professional knowledge. Importantly, it can also help you study for the Navy-wide advancement in rate examination. If you are studying and discover a reference in the text to another publication for further information, look it up.

*1992 Edition Prepared by  
EMC(SW) E. Charles Santeler*

Published by  
NAVAL EDUCATION AND TRAINING  
PROFESSIONAL DEVELOPMENT  
AND TECHNOLOGY CENTER

**NAVSUP Logistics Tracking Number  
0504-LP-026-7720**

## **Sailor's Creed**

“I am a United States Sailor.

I will support and defend the Constitution of the United States of America and I will obey the orders of those appointed over me.

I represent the fighting spirit of the Navy and those who have gone before me to defend freedom and democracy around the world.

I proudly serve my country's Navy combat team with honor, courage and commitment.

I am committed to excellence and the fair treatment of all.”

# CONTENTS

CHAPTER	Page
1. Engineering Administration . . . . .	1-1
2. Engineering Fundamentals . . . . .	2-1
3. Basic Steam Cycle . . . . .	3-1
4. Boilers . . . . .	4-1
5. Steam Turbines . . . . .	5-1
6. Gas Turbines . . . . .	6-1
7. Internal-Combustion Engines . . . . .	7-1
8. Ship Propulsion . . . . .	8-1
9. Pumps, Valves, and Piping . . . . .	9-1
10. Auxiliary Machinery and Equipment . . . . .	10-1
11. Instruments . . . . .	11-1
12. Shipboard Electrical Equipment . . . . .	12-1
13. Environmental Controls . . . . .	13-1
APPENDIX	
I. Glossary . . . . .	AI-1
II. References . . . . .	AII-I
INDEX . . . . .	INDEX-1

# INSTRUCTIONS FOR TAKING THE COURSE

## ASSIGNMENTS

The text pages that you are to study are listed at the beginning of each assignment. Study these pages carefully before attempting to answer the questions. Pay close attention to tables and illustrations and read the learning objectives. The learning objectives state what you should be able to do after studying the material. Answering the questions correctly helps you accomplish the objectives.

## SELECTING YOUR ANSWERS

Read each question carefully, then select the BEST answer. You may refer freely to the text. The answers must be the result of your own work and decisions. You are prohibited from referring to or copying the answers of others and from giving answers to anyone else taking the course.

## SUBMITTING YOUR ASSIGNMENTS

To have your assignments graded, you must be enrolled in the course with the Nonresident Training Course Administration Branch at the Naval Education and Training Professional Development and Technology Center (NETPDTC). Following enrollment, there are two ways of having your assignments graded: (1) use the Internet to submit your assignments as you complete them, or (2) send all the assignments at one time by mail to NETPDTC.

**Grading on the Internet:** Advantages to Internet grading are:

- you may submit your answers as soon as you complete an assignment, and
- you get your results faster; usually by the next working day (approximately 24 hours).

In addition to receiving grade results for each assignment, you will receive course completion confirmation once you have completed all the

assignments. To submit your assignment answers via the Internet, go to:

**<http://courses.cnet.navy.mil>**

**Grading by Mail:** When you submit answer sheets by mail, send all of your assignments at one time. Do NOT submit individual answer sheets for grading. Mail all of your assignments in an envelope, which you either provide yourself or obtain from your nearest Educational Services Officer (ESO). Submit answer sheets to:

COMMANDING OFFICER  
NETPDTC N331  
6490 SAUFLEY FIELD ROAD  
PENSACOLA FL 32559-5000

**Answer Sheets:** All courses include one “scannable” answer sheet for each assignment. These answer sheets are preprinted with your SSN, name, assignment number, and course number. Explanations for completing the answer sheets are on the answer sheet.

**Do not use answer sheet reproductions:** Use only the original answer sheets that we provide—reproductions will not work with our scanning equipment and cannot be processed.

Follow the instructions for marking your answers on the answer sheet. Be sure that blocks 1, 2, and 3 are filled in correctly. This information is necessary for your course to be properly processed and for you to receive credit for your work.

## COMPLETION TIME

Courses must be completed within 12 months from the date of enrollment. This includes time required to resubmit failed assignments.

## **PASS/FAIL ASSIGNMENT PROCEDURES**

If your overall course score is 3.2 or higher, you will pass the course and will not be required to resubmit assignments. Once your assignments have been graded you will receive course completion confirmation.

If you receive less than a 3.2 on any assignment and your overall course score is below 3.2, you will be given the opportunity to resubmit failed assignments. **You may resubmit failed assignments only once.** Internet students will receive notification when they have failed an assignment--they may then resubmit failed assignments on the web site. Internet students may view and print results for failed assignments from the web site. Students who submit by mail will receive a failing result letter and a new answer sheet for resubmission of each failed assignment.

## **COMPLETION CONFIRMATION**

After successfully completing this course, you will receive a letter of completion.

## **ERRATA**

Errata are used to correct minor errors or delete obsolete information in a course. Errata may also be used to provide instructions to the student. If a course has an errata, it will be included as the first page(s) after the front cover. Errata for all courses can be accessed and viewed/downloaded at:

<http://www.advancement.cnet.navy.mil>

## **STUDENT FEEDBACK QUESTIONS**

We value your suggestions, questions, and criticisms on our courses. If you would like to communicate with us regarding this course, we encourage you, if possible, to use e-mail. If you write or fax, please use a copy of the Student Comment form that follows this page.

## **For subject matter questions:**

E-mail: n314.products@cnet.navy.mil  
Phone: Comm: (850) 452-1001, Ext. 1826  
DSN: 922-1001, Ext. 1826  
FAX: (850) 452-1370  
(Do not fax answer sheets.)  
Address: COMMANDING OFFICER  
NETPDTC N314  
6490 SAUFLEY FIELD ROAD  
PENSACOLA FL 32509-5237

## **For enrollment, shipping, grading, or completion letter questions**

E-mail: fleetservices@cnet.navy.mil  
Phone: Toll Free: 877-264-8583  
Comm: (850) 452-1511/1181/1859  
DSN: 922-1511/1181/1859  
FAX: (850) 452-1370  
(Do not fax answer sheets.)  
Address: COMMANDING OFFICER  
NETPDTC N331  
6490 SAUFLEY FIELD ROAD  
PENSACOLA FL 32559-5000

## **NAVAL RESERVE RETIREMENT CREDIT**

If you are a member of the Naval Reserve, you may earn retirement points for successfully completing this course, if authorized under current directives governing retirement of Naval Reserve personnel. For Naval Reserve retirement, this course is evaluated at 9 points. (Refer to *Administrative Procedures for Naval Reservists on Inactive Duty*, BUPERSINST 1001.39, for more information about retirement points.)





## Student Comments

**Course Title:** Fireman

**NAVEDTRA:** 14104 **Date:** \_\_\_\_\_

**We need some information about you:**

Rate/Rank and Name: \_\_\_\_\_ SSN: \_\_\_\_\_ Command/Unit \_\_\_\_\_

Street Address: \_\_\_\_\_ City: \_\_\_\_\_ State/FPO: \_\_\_\_\_ Zip \_\_\_\_\_

**Your comments, suggestions, etc.:**

<p><b>Privacy Act Statement:</b> Under authority of Title 5, USC 301, information regarding your military status is requested in processing your comments and in preparing a reply. This information will not be divulged without written authorization to anyone other than those within DOD for official use in determining performance.</p>
--

NETPDTC 1550/41 (Rev 4-00)



## CHAPTER 1

# ENGINEERING ADMINISTRATION

The Navy has many programs that will affect you at some time in your Navy career. In this chapter you will learn the basics of some of the programs that will affect you as a Fireman. This chapter is not designed to make you an expert in any of these programs, rather it will make you aware of their existence and advise you where to seek more in-depth information. Programs we discuss include only those you will need to know about while carrying out your assigned duties.

After studying this chapter, you should be able to identify the organizational structure of the engineering department, have a general understanding of each engineering rating, and be able to incorporate general safety precautions to perform your day-to-day tasks. You should be able to discuss with some accuracy the various programs pertinent to you as an engineer; that is, the planned maintenance system (PMS), the equipment tag-out program, and the engineering operational sequencing system (EOSS).

### STANDARD SHIP ORGANIZATION

The responsibility for organization of the officers and crew of a ship belongs to the commanding officer by U.S. Navy regulations. The executive officer is responsible, under the commanding officer, for organization of the command. The department heads are responsible for the organization of their departments for readiness in battle and for assigning individuals to stations and duties within their respective departments. The *Standard Organization and Regulations of the U.S. Navy* manual (SORM), OPNAVINST 3120.32B, prescribes this administrative organization for all types of ships.

### ORGANIZATION OF THE ENGINEERING DEPARTMENT

The SORM organizes the engineering department for the efficient operation, maintenance, and

repair of the ship's propulsion plant, auxiliary machinery, and piping systems. The engineering department is responsible for (1) damage control, (2) operation and maintenance of electric generators and distribution systems, (3) repair to the ship's hull, and (4) general shipboard repairs.

The organization of each engineering department varies according to the size of the ship and the engineering plant. For example, forces afloat, such as repair ships and tenders, have a separate repair department with many engineering ratings responsible for off-ship repair and maintenance. These ships also have a standard ship's force engineering department. Smaller ships, because of the smaller number of engineering ratings aboard, combine many ratings into one division.

Figure 1-1 is an example of the organizational structure of the engineering department aboard any large ship. Note that the administrative assistant and the special assistants are aides to the engineer officer. These responsibilities are often assigned as additional duties to officers functioning in other capacities.

The three main assistants to the engineer officer are the main propulsion assistant (MPA), the electrical officer, and the damage control assistant (DCA). Each assistant is assigned the division(s) shown on the organization chart.

The division officers are responsible for the various divisions. The organization of each division by sections is set up by the watch, quarter, and station bill.

### ENGINEER OFFICER

The engineer officer is the head of the engineering department. Besides the duties as a department head, the engineer officer is responsible for the following areas:

- Operation, care, and maintenance of all propulsion and auxiliary machinery
- Control of damage

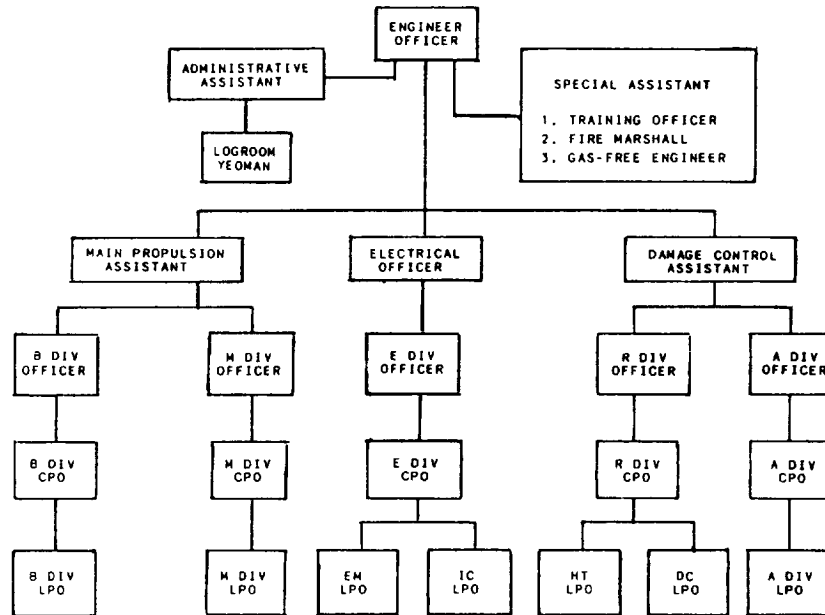

Figure 1-1.—Typical engineering department.

- Completion of all repairs within the capacity of the shops in the engineering department

For more detailed information about the duties and responsibilities of the engineer officer, refer to the *U.S. Navy Regulations*, the *Engineering Department Organization and Regulations Manual* (EDORM), and the SORM.

#### Assistants to the Engineer Officer

The engineer officer is assigned assistants for main propulsion, electrical, damage control, and other specific duties that are required for the proper performance of the functions of the engineering department. The engineer officer must make sure the assistants perform their assigned duties. In the following paragraphs, we will describe the duties of the administrative assistant, training officer, fire marshal, gas-free engineer, MPA, electrical officer, and DCA.

**ADMINISTRATIVE ASSISTANT.**— The department administrative assistant functions as an aide to the engineer officer in the details of administration. The responsibilities and duties of the department administrative assistant are as follows:

- Supervise the operation of the department administrative office; this includes the

upkeep of assigned office spaces and the care and maintenance of office equipment.

- Screen all department incoming correspondence and initiate required action; also, screen and ensure correct preparation of all outgoing correspondence.
- Assist in the preparation of all department directives and exercise control over their issuance.
- Supervise the maintenance of department records and maintain a tickler file on all required reports.
- Coordinate the preparation of the department daily watch bill.
- Assign tasks to, and evaluate the performance of, department yeomen and other enlisted personnel assigned to the department office.

In an engineering department without an administrative assistant billet, the engineer officer may delegate the duties of such a billet to any competent person.

**TRAINING OFFICER.**— The duties of a department training officer are delegated by the

engineer officer to an assistant. Some of these duties include the following:

- Develop a department training program in support of the training objectives of the ship.
- Carry out approved training plans and policies within the department.
- Coordinate and assist in the administration of division training programs within the department. This includes supervision of the preparation of training materials and review of curricula, training courses, and lesson plans. It also includes assisting in the selection and training of instructors, observation of instruction given at drills, on watch, on station, and in the classroom. It further includes procurement of required training aids and devices.
- Maintain department training records and training reports.
- Disseminate information concerning the availability of fleet and service schools.
- Requisition training supplies and materials.

**FIRE MARSHAL.**— The fire marshal works under the engineer officer and the DCA and is responsible for the maintenance and readiness of the ship's fire-fighting equipment. The fire marshal is also responsible for the prevention and elimination of fire hazards on the ship.

**GAS-FREE ENGINEER.**— The duties and responsibilities of the gas-free engineer are described in *Naval Ships' Technical Manual*, chapter 074, volume 3, "Gas-Free Engineering." Briefly, the gas-free engineer tests and analyzes the air in sealed compartments or voids that are being opened for inspection. The engineer determines whether such spaces are safe for personnel to enter without danger of poisoning or suffocation. The engineer also determines whether it is safe to perform welding or cutting within or in the vicinity of such spaces. Such hot work is dangerous and can cause fires and explosions.

**MAIN PROPULSION ASSISTANT.**— The responsibilities of the MPA are as follows:

- Operation, care, and maintenance of the ship's propulsion machinery and related auxiliaries
- Care, stowage, and use of fuels and lubricating oils
- Preparation and care of the Engineering Log and the Engineer's Bell Book
- Preparation of operation and maintenance records and procedures

The MPA also has the responsibility as division officer for the boiler and machinery divisions. These divisions are discussed in the following paragraphs.

**Boiler (B) Division.**— The B division operates the boilers and the fireroom auxiliary machinery. If you are assigned to this division, your work station may be in a fireroom. The firerooms are usually located midships on the lower level. There may be as many as eight firerooms, depending on the size and type of ship. Ships with only one fireroom will have two boilers. They are installed either facing each other or side by side. The boilers are arranged so any number of them supply steam to the ship's engines. The firerooms are separated by watertight bulkheads. This allows any fireroom to be sealed off in case of a casualty. The ship can operate on the remaining boilers.

On your first trip through the fireroom, you will notice many sizes of pipes and valves. These lines (pipes) carry steam, water, fuel oil, and air. You will become familiar with a few of them at a time. Gradually, you will learn all their purposes and functions.

The lines that carry steam or water are covered by insulation and lagging. This is done to ensure personnel safety and to prevent heat loss and condensation. Stencils on the lines show the fluid carried and the direction of flow.

During your training, you will trace these lines from one unit to another throughout each system. The ship's blueprints and drawings will help you trace out systems in the engineering plant.

**Machinery (M) Division.**— The M division is responsible for the safe operation of the main engines, reduction gears, shafting, bearings, and all associated auxiliary machinery that supports

this equipment. When assigned to this division, you will work in one of the engine rooms. The engine rooms are generally located immediately aft of the firerooms that supply them with steam.

**ELECTRICAL OFFICER.**— The electrical officer is designated E division officer and electrical safety officer. The electrical officer is responsible to the engineer officer. The following are the specific duties and responsibilities of the electrical officer:

- Routinely observe the performance of personnel and equipment to ensure efficiency and safety and take action to correct deficiencies
- Administer and execute the ship's electrical safety program using the most up-to-date instructions and notices
- Provide training to the crew routinely on electrical safety

The E division has charge of enforcing the electrical safety program for both personal and shipboard electrical equipment. It maintains generators, power and lighting distribution, gyrocompasses, intercommunications, and other electrical equipment throughout the ship. If assigned to this division, you may work in the main motor rooms, the engine rooms, the electric repair shop, or in the interior communications (IC) rooms.

**DAMAGE CONTROL ASSISTANT.**— The DCA is responsible for the prevention and control of damage. This includes control of stability, list, and trim. Material conditions of readiness, watertight integrity, and compartment testing are carried out under the supervision of the DCA. The DCA administers various training for ship's personnel. This training includes damage control, fire fighting, emergency repair work, and nonmedical defensive measures for chemical, biological, and radiological (CBR) defense.

The DCA is in charge of the hull maintenance (R division) and the auxiliary machinery (A division) shops. In these shops repairs to the ship's hull and the ship's boats, which are within the ship's capabilities, are made by the assigned personnel. These divisions are described in the following paragraphs.

**Repair (R) Division.**— The R division is responsible for keeping the ship watertight. The

R division operates the hull maintenance shops. This division maintains damage control and fire-fighting equipment and assists in damage-control training for shipboard personnel.

**Auxiliary (A) Division.**— The A division operates the refrigeration plant, air compressors, emergency fire pumps, emergency diesel generators, and the ventilation, heating, and air-conditioning systems. They are the boat engineers in small boats. They also maintain the ship's steering engines. If assigned to this division, you may work in the auxiliary spaces or parts of the ship under A division's authority. The equipment assigned to A division is found throughout the ship.

### **Division Officer**

The duties of a division officer are described in the *U.S. Navy Regulations* and the SORM. The following are specific duties and responsibilities of the division officer:

- Direct the division through work center supervisors.
- Assign watches and duties within the division.
- Ensure that division personnel receive indoctrination and military and professional training.
- Prepare enlisted performance evaluation sheets for personnel of the division.
- Maintain a division notebook containing personnel data cards, training data, a space and equipment responsibility log, and the watch and battle stations requirements. The notebook also has data useful for ready reference and for the orientation of a relief officer.
- Account for all forms, reports, and correspondence originated or maintained by the division.
- Establish and maintain a division organization manual and other directives necessary for the administration of the division.
- Ensure that prescribed security measures are strictly observed by division personnel.

- Recommend to the department head personnel transfers and changes in the division allowance.
- Forward requests for leave, liberty, and special privileges. This includes making recommendations for their disposition.
- Conduct periodic inspections, exercises, and musters.
- Evaluate the performance and discipline of the division.

The division chief petty officer (CPO) and division leading petty officer (LPO) are assigned to aid the division officer in the administrative, organizational, and disciplinary duties. Their function within the division is discussed in the following paragraphs.

**DIVISION CHIEF PETTY OFFICER.**— The function of a division CPO is to assist the division officer in coordinating and administering the division. The duties, responsibilities, and authority of the division CPO depends on the division organization. The division CPO may be required to perform the following tasks:

- Supervise the preparation and maintenance of the watch, quarter, and station bill.
- Formulate and implement policies and procedures for the operation of the division.
- Supervise the division in the performance of its daily routine and conduct inspections.
- Administer discipline within the division.
- Complete Enlisted Performance Evaluation Reports (NAVPERS 1616/24) after evaluating individual performances. The LPO assists the CPO in this task.
- Provide counsel and guidance to division personnel.
- Ensure routine logs and records are maintained correctly and required division reports are prepared properly.
- Act as the division officer in his or her absence.
- Perform other duties assigned by the division officer.

**DIVISION LEADING PETTY OFFICER.**—

The LPO appointed by the division officer or CPO is usually the senior petty officer in the division. The LPO will assist in the administration, supervision, training, and watch standing qualifications of division personnel.

**ENLISTED PERSONNEL**

Besides the general ratings, some specific billets or assignments require special mention. Two of these billets are the oil and water king and the boat engineer.

**Oil and Water King**

On large ships, the billet for oil and water king is divided into two billets—one for fuel oil and the other for potable (fresh) water and feedwater.

On steam-driven ships, the oil and water king could be either a Boiler Technician or a Machinist's Mate. On diesel- and gas turbine-driven ships, the oil and water king is an Engineman or a Gas Turbine Systems Technician. The responsibilities of an oil and water king are as follows:

- Supervise the operation of all valves in the fuel oil and transfer system and the freshwater system, as prescribed by the casualty control bills for those systems.
- Properly maintain fuel oil service tanks and shift suction among service tanks.
- Maintain the distribution of fuel oil and water so the ship can remain on an even keel and in proper trim.
- Prepare fuel and water reports.
- Test and record the pH, phosphate, chloride content, hardness, and other properties of feed and boiler water.
- Test and record fuel oil samples. For detailed information on these tests, refer to *Naval Ships' Technical Manual*, chapter 541, "Petroleum Fuel Stowage, Use, and Testing," and chapter 220, volume 2, "Boiler Water/Feedwater Tests and Treatment."

Refer to *Basic Military Requirements*, NAVEDTRA 10054-F, chapter 19, for information on safety precautions to be observed when handling fuel oil.

## Small Boat Engineer

Firemen, Enginemen, or Machinist's Mates from the A division are detailed as boat engineers. Boat engineers operate, clean, and inspect the section of the boats assigned to them. Boat engines are repaired by Enginemen.

When a ship is at anchor, the officers and crew usually travel to and from the shore in small boats. As a Fireman, you may be assigned as an engineer on one of these boats. You will be responsible for operating the boat's engine(s). A coxswain will be in charge of the overall operation of the boat. On some boats, two seamen may act as bow and stern hooks, or one seaman may act as bowhook and the engineer may act as sternhook.

For additional information on small boats and boat safety, refer to *Basic Military Requirements*, NAVEDTRA 10054-F, and *Seaman*, NAVEDTRA 10120-J.

## ENGINEERING DEPARTMENT RATINGS

In general, the engineering department ratings require (1) an aptitude for mechanical knowledge, (2) a degree of skill in mathematics and physics, and (3) some experience in repair work. A knowledge of mechanical drawing is also desirable. Training manuals (TRAMANs) and nonresident training courses (NRTCs) covering many aspects of basic engineering are available to help you.

Schools for engineering ratings are available to those who qualify. You can find a list of all schools and their requirements in the *Catalog of Navy Training Courses* (CANTRAC), NAVEDTRA 10500.

In this section we will describe the titles and jobs of the various engineering ratings. The engineering ratings are classified into two occupational fields—marine engineering and ship maintenance.

### MARINE ENGINEERING OCCUPATIONAL FIELD

The marine engineering occupational field includes the Machinist's Mate, Engineman, Boiler Technician, Electrician's Mate, Interior Communications Electrician, Gas Turbine Systems Technician (Electrical), and Gas Turbine Systems Technician (Mechanical) ratings. In the

following paragraphs we will describe these ratings:

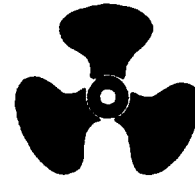

**Machinist's Mate (MM)**

**MACHINIST'S MATES** operate and maintain ship propulsion machinery, reduction gears, condensers, and air ejectors. They are also responsible for miscellaneous auxiliary equipment. This includes pumps, air compressors, turbine-driven generators, distilling units, valves, oil purifiers, oil and water heaters, governors, air-conditioners, refrigeration, propeller shafts, potable water systems, and ship's steering and various other hydraulic systems.

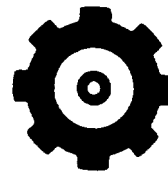

**Engineman (EN)**

**ENGINEMEN** work primarily with reciprocating engines (diesel and gasoline). They operate, maintain, and repair diesel propulsion plants and diesel engines used for ship's service generators, and supporting auxiliary equipment. Such equipment includes refrigeration and air-conditioning systems, pumps, air compressors, auxiliary boilers, distillers, and various kinds of hydraulic equipment.



**Boiler Technician (BT)**

**BOILER TECHNICIANS** operate, maintain, test, and repair marine boilers, heat exchangers, pumps, and forced draft blowers. They also transfer, test, and take soundings and inventory of fuel and feedwater tanks.





**Electrician's Mate (EM)**

**ELECTRICIAN'S MATES** stand watch on generators and switchboards. They maintain and repair power and lighting circuits, electrical fixtures, motors, generators, distribution switchboards, and other electrical equipment. They test for grounds, or other casualties, and repair or rebuild electrical equipment in the electrical shop. They also maintain motion-picture equipment aboard ship.

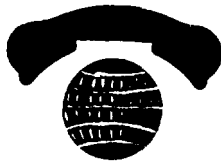

**Interior Communications Electrician (IC)**

**INTERIOR COMMUNICATIONS ELECTRICIANS** operate, maintain, and repair IC systems. These systems include gyrocompass, voice interior communications, alarm, warning, ship's control, entertainment, and plotting. They also stand watches on related equipment.



**Gas Turbine Systems Technician (GS)**

The **GAS TURBINE SYSTEMS TECHNICIAN** rating is divided into two groups: the Gas Turbine Systems Technician (Electrical) (GSE) and the Gas Turbine Systems Technician (Mechanical) (GSM).

The GSEs operate, repair, and perform preventive and corrective maintenance on the electrical components of gas turbine engines, main propulsion machinery, auxiliary equipment, propulsion control systems, electrical and electronic circuitry in the engineering spaces, and alarm and warning circuits.

The GSMs operate, repair, and perform preventive and corrective maintenance on

mechanical components of gas turbine engines, main propulsion machinery (gears, shafts, and controllable pitch propellers), auxiliary equipment in the engineering spaces, and propulsion control systems.

**SHIP MAINTENANCE  
OCCUPATIONAL FIELD**

The ship maintenance occupational field includes the Hull Maintenance Technician, Damage Controlman, Machinery Repairman, Molder, Instrumentman, Opticalman, and Patternmaker ratings. In the following paragraphs we will describe these ratings:



**Hull Maintenance Technician (HT)**

**HULL MAINTENANCE TECHNICIANS** plan, supervise, and perform tasks to fabricate, install, and repair various structures, shipboard and shore-based plumbing, and piping systems.



**Damage Controlman (DC)**

**DAMAGE CONTROLMEN** are qualified in the skills and techniques of damage control, fire fighting, and CBR defense. They must be able to take all measures required to maintain the watertight integrity of the ship. They must also be able to coordinate damage-control efforts and instruct other ratings in damage-control procedures.



**Machinery Repairman (MR)**

**MACHINERY REPAIRMEN** make all types of machine shop repairs on shipboard machinery. This work requires skill in using lathes, milling machines, boring mills, grinders, power hacksaws, drill presses, and other machine tools. It also requires skill in using hand tools and measuring

instruments usually found in a machine shop. The job of restoring machinery to good working order may range from making a simple pin or link to the complete rebuilding of an intricate gear system. Often, without dimensional drawings or other design information, a Machinery Repairman must depend on ingenuity and know-how to machine a repair part successfully.



**Molder (ML)**

**MOLDERS** operate foundries aboard ship and at shore stations. They make molds and cores, rig flasks, prepare heats, and pour castings of ferrous, nonferrous, and alloy metals. They also shake out and clean castings and pour bearings.



**Instrumentman (IM)**

**INSTRUMENTMEN** perform preventive and corrective maintenance and calibration on mechanical instruments and standards and Navy timepieces. They use Navy or mechanical instrument repair and calibration shop (MIRCS) procedures.

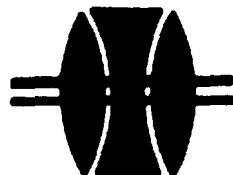

**Opticalman (OM)**

**OPTICALMEN** perform preventive and corrective maintenance on small navigational instruments, binoculars, gun sights, range finders, submarine and turret periscopes, night vision sights, and other optical instruments.



**Patternmaker (PM)**

**PATTERNMAKERS** make wooden, plastic, plaster, and metal patterns used by Molders in a Navy foundry. They mount patterns on matchboard/match plates for production molding. Patternmakers make master patterns, full-scale layouts of wooden patterns, coreboxes, and templates. They also index and store patterns.

## **SAFETY PROGRAM**

The objective of the Navy's Safety Program is to enhance operational readiness by reducing the frequency and severity of on- and off-duty mishaps to personnel and the cost of material and property damage attributed to accidental causes. The use of the term *safety program* in this chapter signifies both occupational safety and health.

Operating and maintenance personnel must be familiar with technical manuals and other publications concerning equipment they are working with. Personnel must continuously exercise good judgment and common sense in the setting-up and operation of all equipment to prevent damage to the equipment and injury to personnel.

Personnel can prevent damage to machinery by properly preparing and operating the equipment by following instructions and procedures outlined in the EOSS (which is discussed later in this chapter) and by being completely familiar with all parts and functions of the machinery.

You can prevent damage to the ship by operating the machinery so no loss of power occurs at an inopportune time, by keeping engines ready for service in any emergency, and by preventing hazardous conditions that may cause fire or explosion. Always maintain fire-fighting equipment in a "ready to use" state.

You can prevent injury to personnel by having a thorough knowledge of duties, by knowing how to properly handle tools and operate equipment, by observing normal precautions around moving parts, and by receiving constant training.

Other everyday safety habits you should follow include (1) preventing the accumulation of oil in the bilges or other pockets or foundations and subbases; (2) taking care, particularly when on an uneven keel, that water in the bilges does

not reach electrical machinery or wiring; and (3) ensuring that safety guards are provided at potential danger points, such as rotating and reciprocating equipment.

For personnel and machinery safety, you must adhere to the following safety precautions specifically related to the engineering department:

- Do not attempt to operate equipment by overriding automatic shutdown or warning devices.
- Tag-out and disconnect batteries or other sources of electrical power before performing maintenance. This prevents injuries from short circuits and accidental start-up of equipment.
- Avoid holding or touching spark plugs, ignition units, or high-tension leads while they are energized.
- Do not use oxygen to pressure test fuel lines and equipment.
- Take precautions to avoid inhaling vapors of lacquer thinner, trichlorethylene, and similar solvents.
- Do not wear jewelry or watches while working in machinery spaces.
- Take precautions to avoid touching exposed hot parts of an engine. Do not perform maintenance work until the engine has been shut down and cooled.
- Wear proper ear protection in all main machinery spaces.

It is the responsibility of supervisory personnel to ensure that their subordinates are instructed in and carry out the applicable safety precautions. Each individual is responsible for knowing and observing all safety precautions applicable to their living or working spaces. Refer to *Navy Safety Precautions for Forces Afloat*, OPNAVINST 5100.19.

### **SHIPS' MAINTENANCE AND MATERIAL MANAGEMENT (3-M) SYSTEMS**

The *Ships' Maintenance and Material Management (3-M) Manual*, OPNAVINST 4790.4, describes in detail the Ships' 3-M Systems. The

primary objective of the Ships' 3-M Systems is to provide for managing maintenance and maintenance support in a way to ensure maximum equipment operational readiness. The Ships' 3-M Systems is divided into two subsystems. They are the planned maintenance system (PMS) and the maintenance data system (MDS).

### **PURPOSES OF PMS**

The PMS was established for the following purposes:

- To reduce complex maintenance to simplified procedures that are easily identified and managed at all levels
- To define the minimum planned maintenance required to schedule and control PMS performances
- To describe the methods and tools to be used
- To provide for the detection and prevention of impending casualties
- To forecast and plan personnel and material requirements
- To plan and schedule maintenance tasks
- To estimate and evaluate material readiness
- To detect areas requiring additional or improved personnel training and/or improved maintenance techniques or attention
- To provide increased readiness of the ship

### **BENEFITS OF PMS**

The PMS is a tool of command. By using PMS, the commanding officer can readily determine whether the ship is being properly maintained. Reliability and availability are improved. Preventive maintenance reduces the need for major corrective maintenance, increases economy, and saves the cost of repairs.

The PMS assures better records because the shipboard maintenance manager has more useful data. The flexibility of the system allows for programming of inevitable changes in employment schedules. This helps to better plan preventive maintenance.

The PMS helps leadership and management reduce frustrating breakdowns and irregular hours of work, and thus improves morale. It enhances the effectiveness of all hands.

## LIMITATIONS OF PMS

The PMS is not self-starting; it does not automatically produce good results. It requires considerable professional guidance and continuous direction at each level of the system's operation. One individual must have both the authority and the responsibility at each level of the system's operation.

Training in the maintenance steps as well as in the system is necessary. No system is a substitute for the actual technical ability required of the petty officers who direct and perform the upkeep of the equipment. Because of rapid changes in the Ships' 3-M Systems, always refer to a current copy of the 3-M *Manual*.

## EQUIPMENT TAG-OUT PROGRAM

An effective tag-out program is necessary because of the complexity of modern ships as well as the cost, delay, and hazard to personnel that could result from the improper operation of equipment. The equipment tag-out program is a procedure to prevent improper operation of a component, equipment, system, or part of a system that is isolated or in an abnormal condition. This procedure is also used when safety devices, such as blank flanges on piping, are installed for testing, maintenance, or casualty isolation.

The use of **DANGER** or **CAUTION** tags is not a substitute for other safety measures, such as locking valves or pulling fuses. Tags applied to valves, switches, or other components should indicate restrictions on their operation. Never use tags for identification purposes.

The procedures in this program are mandatory to standardize tag-out procedures used by all ships and repair activities. The program also provides a procedure for use when an instrument is unreliable or is not in normal operating condition. It is similar to the tag-out procedure. However, labels instead of tags are used to indicate instrument status. The tag-out program must be enforced during normal operations as well as during construction, testing, repair, or maintenance. Strict enforcement of tag-out procedures

is required by both you and any repair activity that may be working on your equipment.

## RESPONSIBILITY

The commanding officer is responsible for the safety of the entire command. It is the duty of the commanding officer to ensure that all personnel know all applicable safety precautions and procedures and to ensure compliance with the program. The engineer officer is responsible to the commanding officer for ensuring that personnel assigned to the engineering department understand and comply with this program.

When repairs are done by a repair activity (other than ships' personnel), a dual responsibility exists for the safety of the personnel making repairs. The ship tended is responsible for controlling the tag-out program and ensuring that the systems that require work are properly tagged-out. The repair activity is responsible for ensuring that this is done properly. They verify this by signing the appropriate space on the tag-out sheet and the tag.

## PROCEDURES

After identifying the need to tag-out an item or a system, you must get permission from an authorizing officer. The authorizing officer for the engineering department is the engineering officer of the watch (EOOW) while under way or the engineering duty officer (EDO) while in port. If the item or system tagged is placed out of commission, the authorizing officer must get permission from the engineer officer and the commanding officer. When permission has been received, the authorizing officer then directs you to prepare the tag-out record sheet and tags.

Normally, the petty officer in charge of the work fills out and signs the record sheet and prepares the tags. The record sheet is filled out for a stated purpose. All tags for that purpose are normally listed on one record sheet. Each sheet is assigned a log serial number. All tags associated with it are given the same log serial number and a sequential number is entered on the record sheet. For example, tag E107-4 is the fourth tag issued on the record sheet with the log serial number 107 for engineering.

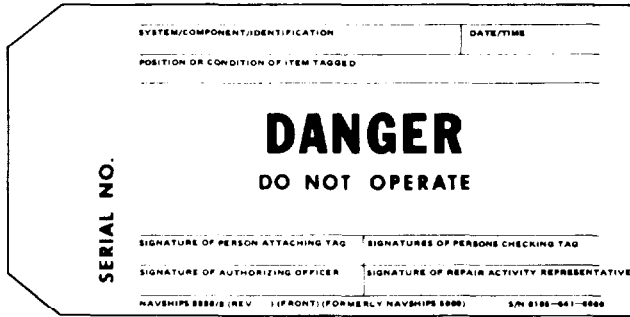

BLACK LETTERING ON RED TAG



BLACK LETTERING ON YELLOW TAG

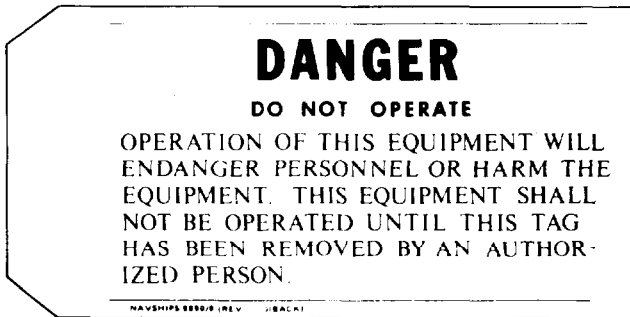

67.330

Figure 1-2.—Danger tag.

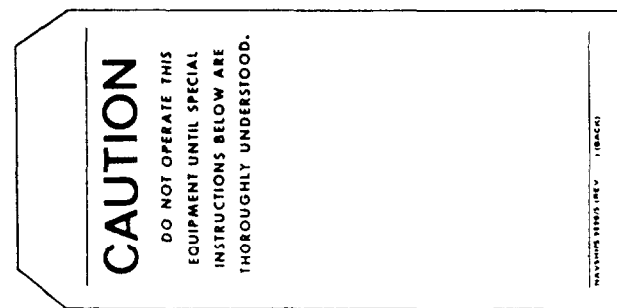

67.329

Figure 1-3.—Caution tag.

The record sheet includes reference to any documents that apply—such as PMS, technical manuals, and other instructions, the reason for the tag-out, the hazards involved, any amplifying instructions, and the work necessary to clear the tags. Use enough tags to completely isolate the item or system being worked on. This will prevent operation from any and all stations that could exercise control. Indicate the location and condition of the tagged item by the simplest means (for example, FOS-11A, closed).

When attaching the tags, you must ensure that the item is in the position or condition indicated on the tag. As you attach each tag, you then must sign the tag and initial the record sheet. After all tags are attached, a second qualified person ensures the items are in the position and condition indicated, and verifies proper tag placement. That person also signs the tags and initials the record sheet.

## TYPES OF TAGS

The following sections describe the various tags and the applications required to be used from time to time.

### Danger Tag

A danger tag is a **RED** tag (fig. 1-2) used to prohibit the operation of equipment that could jeopardize the safety of personnel or endanger equipment. Under no circumstances should equipment be operated when tagged with **DANGER** tags.

### Caution Tag

A caution tag is a **YELLOW** tag (fig. 1-3) used as a precautionary measure to provide temporary special instructions or to indicate that unusual caution must be exercised to operate equipment. These instructions must give the specific reason that the tag was installed. The use of such phrases as **DO NOT OPERATE WITHOUT EOOW PERMISSION** is **NOT APPROPRIATE** since equipment or systems are not operated unless permission has been granted by responsible authority. A **CAUTION** tag is **NOT** used any time personnel or equipment can be endangered while performing evolutions using normal operating procedures; a **DANGER** tag is used in this case.

OUT OF COMMISSION	
SERIAL NO.	DATE
AUTHORIZED BY/ CONCURRENCE BY	
TAG BY	TIME

Figure 1-4.—Out-of-commission label (colored red).

### Out-of-Commission Labels

Out-of-commission labels are **RED** labels (fig. 1-4) used to identify instruments that do not work properly because they are defective or isolated from the system. This indicates the instrument cannot be relied on and must be repaired and recalibrated, or be reconnected to the system before use.

### Out-of-Calibration Labels

Out-of-calibration labels are **ORANGE** labels (fig. 1-5) used to identify instruments that are out of calibration and may not work properly. This label indicates the instrument may be used for system operation only with extreme caution.

### ENFORCEMENT

The tag-out log is kept in a designated space, usually CCS. Supervisory watch standers review the log during watch relief. Active tag-outs are spot checked periodically to ensure tag integrity is being maintained.

An audit of the tag-out log is conducted by the EDO every 2 weeks while in port, prior to getting under way, and weekly if in the yards or at a maintenance availability. Results of the audit are reported to the engineer officer.

OUT OF CALIBRATION	
SERIAL NO.	DATE
AUTHORIZED BY/ CONCURRENCE BY	
TAG BY	TIME
ERROR	

Figure 1-5.—Out-of-calibration label (colored orange).

To ensure that tag-out procedures are enforced properly, the engineer officer checks the log frequently, noting any errors and bringing them to the attention of the proper personnel.

### ENGINEERING OPERATIONAL SEQUENCING SYSTEM

The Navy has developed a system known as EOSS. Essentially, the EOSS is to the operator as the PMS is to the maintainer.

Main propulsion plants in Navy ships are becoming more technically complex with each new class of ship. Increased complexity requires increased engineering skills for proper operation. Ships that lack experienced personnel have material casualties. These casualties jeopardize operational readiness. Rapid turnover of engineering personnel further compounds the problems of developing and maintaining a high level of operator and operating efficiency.

The Navy has been increasingly aware of these problems. An evaluation of the methods and procedures used in operating engineering plants has been completed. The results of these studies show that sound operating techniques were not always followed. Some unusual circumstances found to be prevailing in engineering plants are as follows:

- The information needed by the watch stander was scattered throughout publications that were not readily available.
- The bulk of the publications were not systems oriented. Reporting engineering personnel had to learn specific operating procedures from “old hands” presently assigned. Such practices could ultimately lead to misinformation or degradation of the transferred information. These practices were costly and resulted in nonstandard operating procedures, not only between adjoining spaces, but also between watch sections within the same space.
- Posted operating instructions often did not apply to the installed equipment. They were conflicting or incorrect. Procedures for aligning the various systems with other systems were not provided.

- The light-off and securing schedules were prepared by each ship and were not standardized between ships. The schedules were written for general, rather than specific, equipment or systems. They did not include alternatives between all the existing modes of operation.

Following these studies, NAVSEA developed the EOSS. It is designed to help eliminate operational problems. The EOSS involves the participation of all personnel from the department head to the watch stander. The EOSS is a set of systematic and detailed written procedures. The EOSS uses charts, instructions, and diagrams developed specifically for the operational and casualty control function of a specific ship's engineering plant.

The EOSS is designed to improve the operational readiness of the ship's engineering plant. It does this by increasing its operational efficiency and providing better engineering plant control. It also reduces operational casualties and extends the equipment life. These objectives are accomplished first by defining the levels of control; second, by operating within the engineering plant guidelines; and last, by providing each supervisor and operator with the information needed. This is done by putting these objectives in words they can understand at their watch station.

The EOSS is composed of three basic parts.

- The *User's Guide*
- The engineering operational procedures (EOP)
- The engineering operational casualty control (EOCC)

### **EOSS USER'S GUIDE**

The *User's Guide* is a booklet that explains the EOSS package and how to use it to the ship's best advantage. It has document samples and explains how they are used. It provides recommendations for training the ship's personnel using the specified procedures.

The EOSS documentation is developed using work-study techniques. All existing methods and procedures for plant operation and casualty control procedures are documented. These include the actual ship procedures as well as those procedures contained in available reference sources.

Each action is subjected to a serious review to measure the completeness of the present methods. At the completion of this analytic phase, new procedural steps are developed into an operational sequencing system. Step-by-step, time-sequenced procedures and configuration diagrams are prepared to show the plant layout in relation to operational components. The final step in the development phase of an EOSS is a validation on board ship. This is done to verify technical accuracy and adequacy of the prepared sequencing system. All required corrections are made. They are then incorporated into the package before installation aboard ship.

The resulting sequencing system provides the best tailored operating and casualty control procedures available that apply to a particular ship's propulsion plant. Each level is designed with the information required to enable the engineering plant to respond to any demands placed upon it.

### **ENGINEERING OPERATIONAL PROCEDURES**

The EOP has all the information necessary for the proper operation of a ship's engineering plant. It has guides for scheduling, controlling, and directing plant evolutions through operational modes. This includes receiving shore services, to various modes of in-port auxiliary plant steaming, to underway steaming.

The EOP documentation exists for specifically defined operational stages. These are defined as stages I, II, and III.

Stage I deals with the total engineering plant under the direct responsibility of the plant supervisor (EOOW). The EOOW coordinates the placing in operation and securing of all systems and components normally controlled by the various space supervisors. This person also supervises those functions that affect conditions internal to the engineering plant, such as jacking, testing, and spinning main engines. The EOP documentation helps the plant supervisor guarantee optimum plant operating efficiency, proper sequencing of events in each evolution, and the training of newly assigned personnel. During a plant evolution, the EOOW appoints control and operation of the following systems and components:

- Systems that interconnect one or more engineering plant machinery spaces and electrical systems.

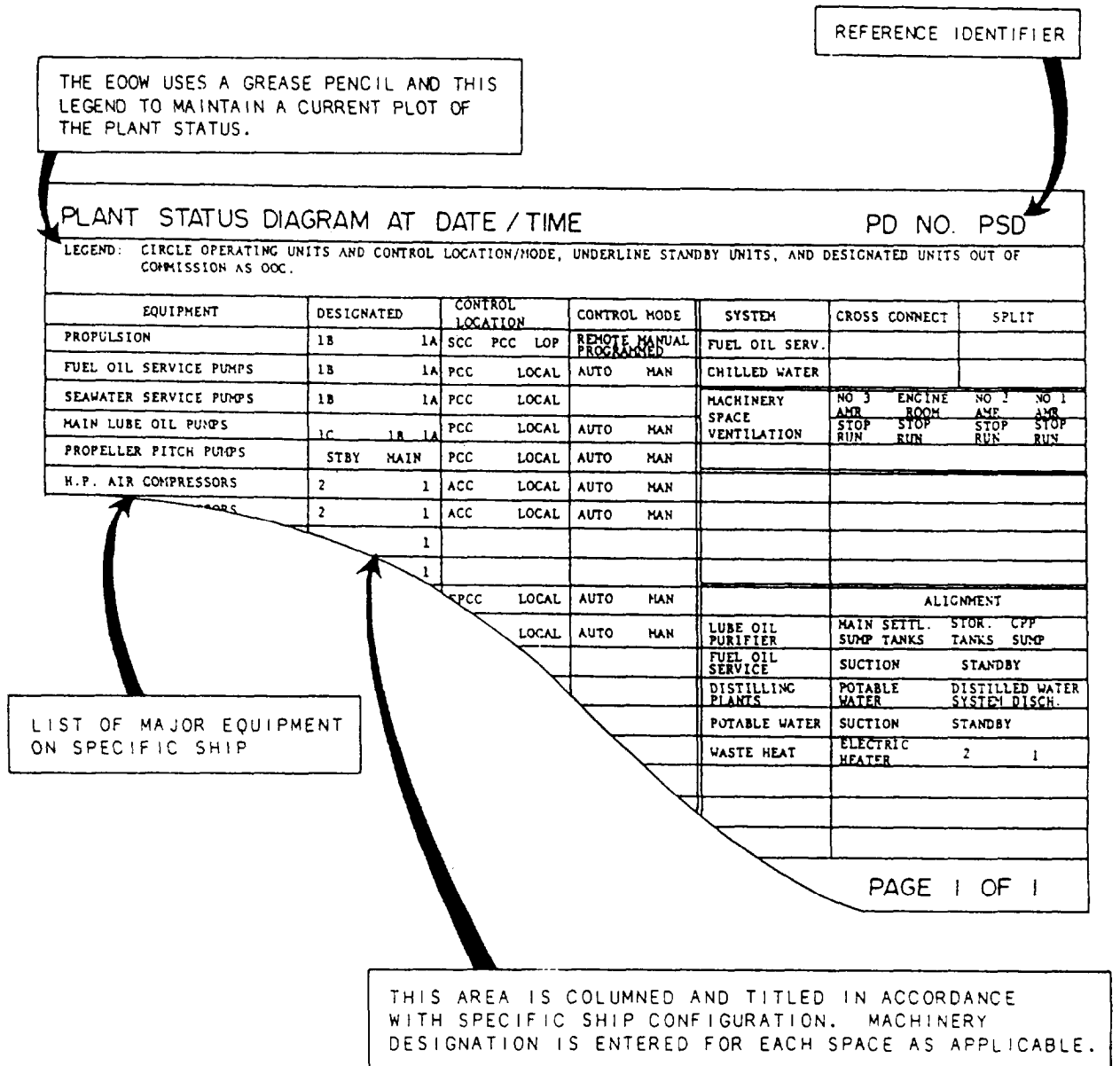

Figure 1-6.—Sample plant status diagram.

- Systems and components required to support the engineering plant or other ship functions, such as distilling plants, air compressors, fire pumps, and auxiliaries. These are placed in operation or secured in response to demand upon their services.

To assist the plant supervisor with these operations, the EOP section provides the following documents:

- Index pages listing each document in the stage I station by identification number and title.

- Plant status diagrams (fig. 1-6) providing a systematic display of the major systems and cross-connect valves as well as a graphic presentation of the major equipment in each machinery space. These diagrams are used to maintain a current plot of systems' alignment and equipment operating status.

- A diagram for plant steaming conditions used to outline the best generator combinations. This diagram shows the preferred electric power generator combinations for



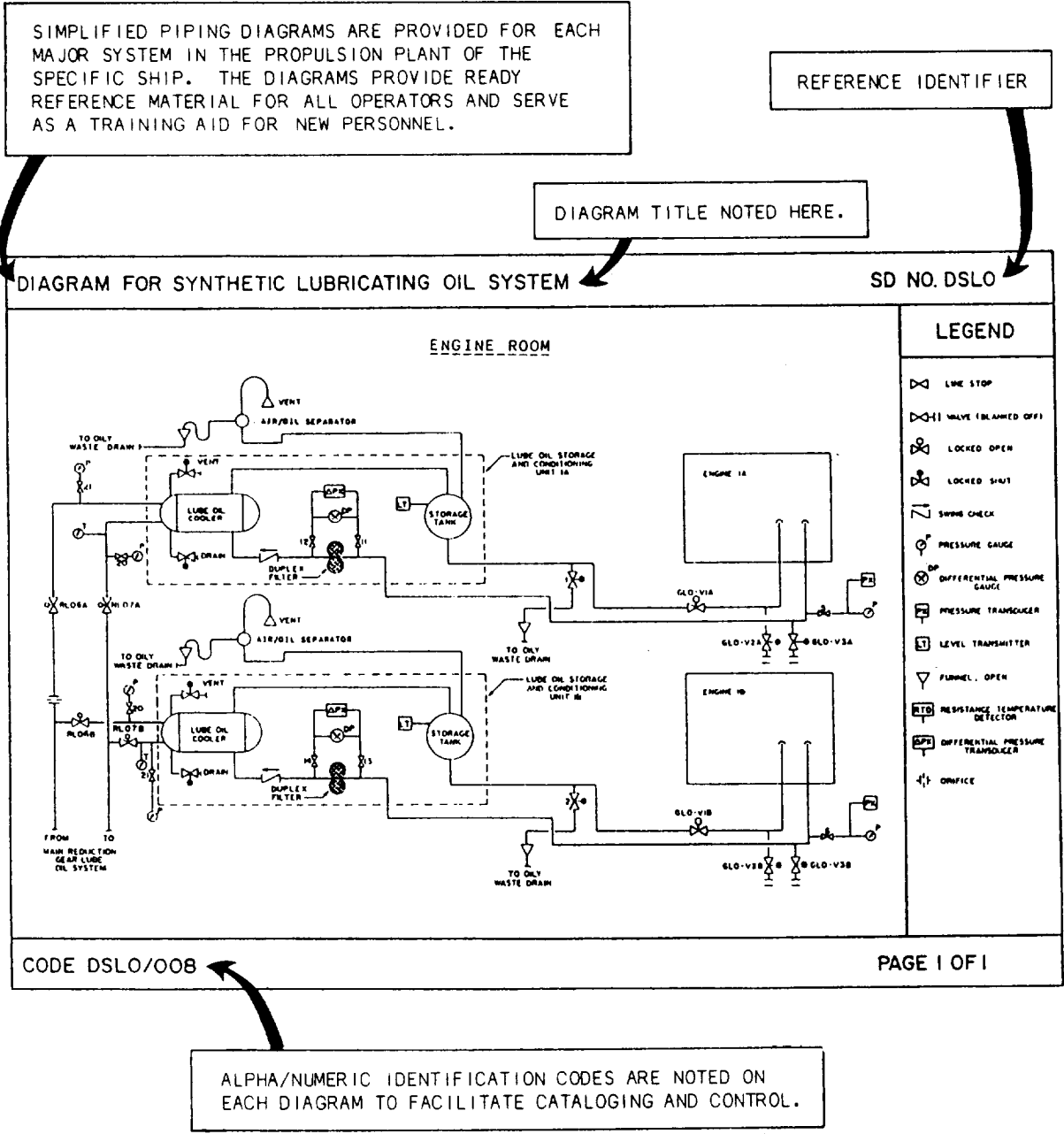

Figure 1-7.—Sample training diagram.

- the various plant operating conditions. This diagram is also provided in the stage II electrical documentation.
- System alignment diagrams showing the preferred initial and final alignment for each engineering plant.
- A diagram for equipment versus speed requirement delineating the equipment normally required for various ship speeds.
- A diagram that shows the location of shore service connections. This diagram traces the connections for steam, electrical power, feedwater, potable water, firemain, and fuel oil.
- Training diagrams (fig. 1-7) outlining each major piping system to aid in plant familiarization and training of personnel. These diagrams indicate the relative locations of lines, valves, and equipment.

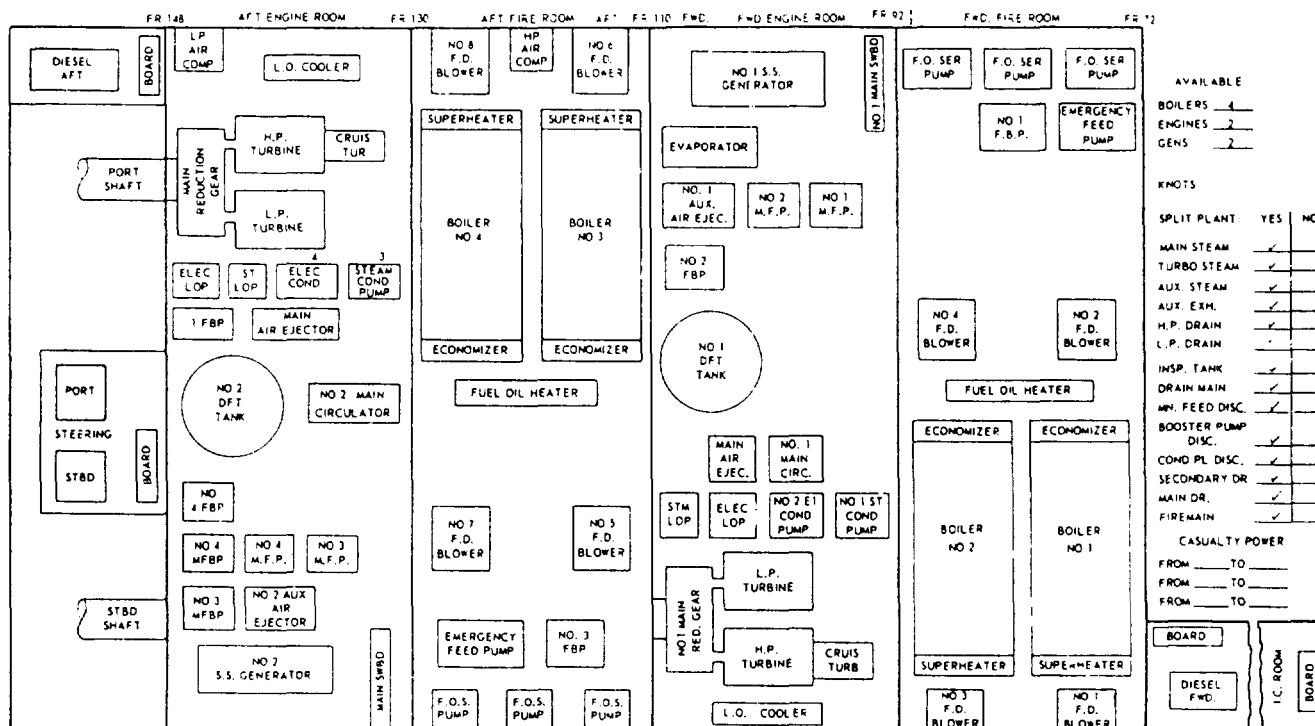

Figure 1-8.—Casualty control board.

Stage II deals with the system component level under supervision of the space supervisor. In stage II, the space supervisor accomplishes the tasks delegated by the plant supervisor (EOOW under way and EDO in port). The EOP documentation assists the space supervisor in properly sequencing events, controlling the operation of equipment, maintaining an up-to-date status of the operational condition of the equipment assigned, and training personnel. To assist the space supervisor in the effort, the EOP section provides the following stage II documents:

- Index pages listing each document by identification number and title for each specified operating group, such as engine rooms (ERs), auxiliary machinery rooms (AMRs), or electrical systems.
- Space procedure charts providing the step-by-step procedures to accomplish and support the requirements of the plant procedure charts.
- Space status board providing a layout of major systems. Allows maintenance personnel and watch standers a visual plot as to the systems alignment and equipment operating status. This board is similar in configuration to the casualty control board

for the stage I documentation shown in figure 1-8.

- Diagram for electrical plant status showing generators, switchboards, and shorepower connections within the electrical distribution systems. This diagram is provided in both the electrical operating group and in the stage I (EOOW) documentation for maintaining a plot of the system alignment.
- Diagram for plant steaming conditions used to plan the best generator combinations provided in the electrical operating group documentation. This specifies the preferred electric power generator combination. This diagram is the same as that provided in the stage I documentation.
- Training diagrams of each major piping system developed for stage I. Other diagrams include individual systems, such as the fuel oil and main engine lube oil systems located within the machinery spaces.

Stage III deals with the system component level under the supervision of component operators. The component operators place

DESCRIPTION OF SPECIFIC DIAGRAM. OPERATIONAL DIAGRAM IS PROVIDED WHEN NECESSARY TO CLARIFY OPERATIONAL PROCEDURE SET FORTH IN A COMPONENT/SYSTEM PROCEDURE CARD.

REFERENCE IDENTIFIER

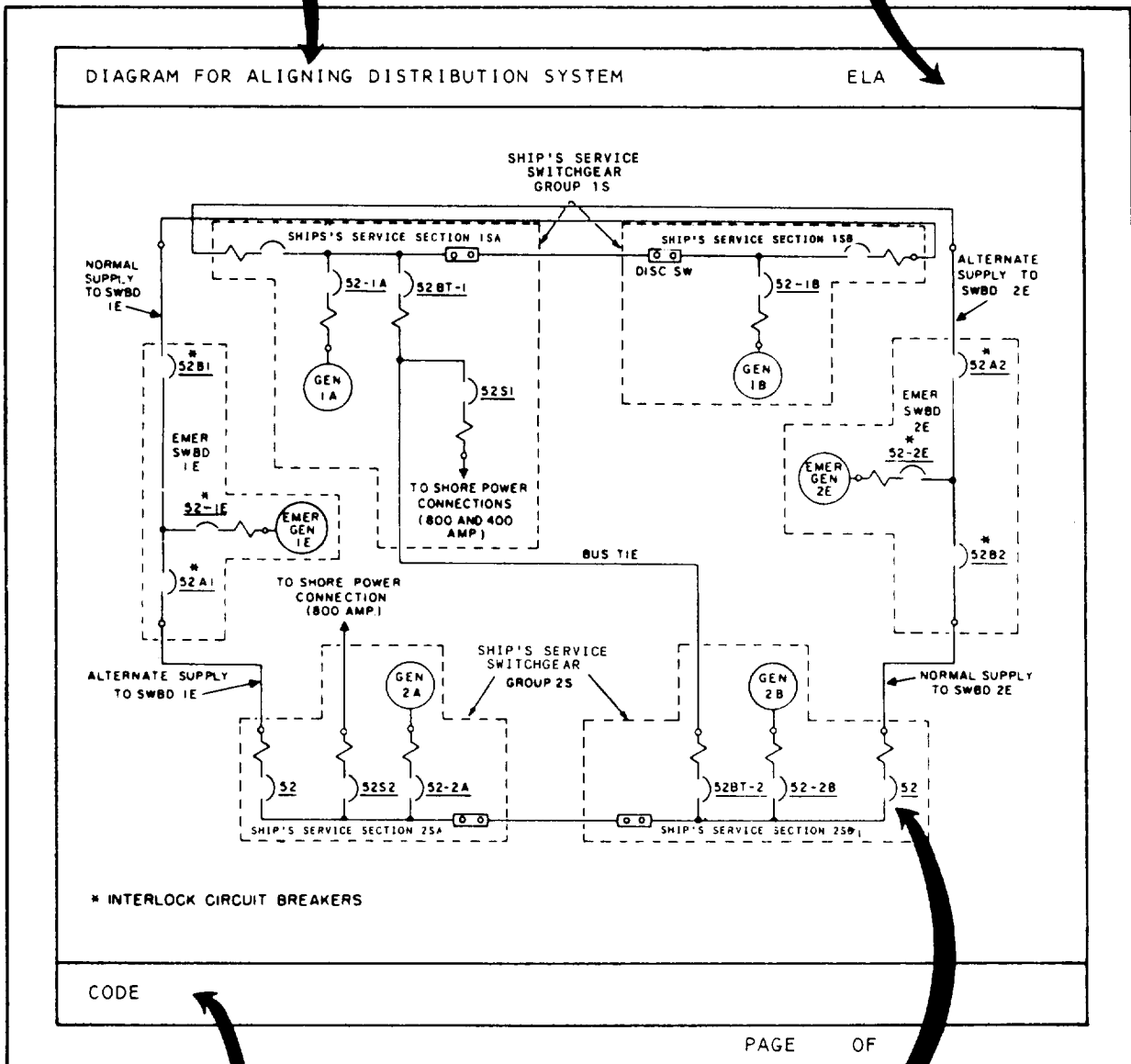

IDENTIFIER FOR CATALOGING AND DOCUMENT CONTROL.

SIMPLIFIED SCHEMATIC OF SPECIFIC SYSTEM UNDER CONSIDERATION. COMPONENT IS NUMBERED TO FACILITATE SYSTEM ALIGNMENT BY OPERATOR AS HE REFERS TO THE RELATED PROCEDURE CARD.

Figure 1-9.—Component/system alignment diagram.

equipment in and out of operation, align systems, and monitor and control their operation. Stage III documents include the following:

- Index pages listing each document by identification number and title for each specific system, such as the fuel oil and lube oil service systems.
- Component procedure cards providing step-by-step procedures for systems' alignment or component operation.
- Component procedure cards as required to support each operation or alignment.
- Alignment diagrams (fig. 1-9) amplifying the written procedure to assist the component

operator in proper systems' alignment. An alignment diagram is used whenever two or more alignment conditions exist for a given system or component.

The operational use of EOP documentation is of primary importance at all levels in controlling, supervising, and operating the engineering plant.

## **ENGINEERING OPERATIONAL CASUALTY CONTROL**

The EOCC is the casualty control portion of the EOSS. It contains information relevant to the recognition of casualty symptoms and their probable causes and effects. Also, it has information on actions taken to prevent a casualty. It specifies procedures for controlling single- and multiple-source casualties.

Casualty prevention must be the concern of everyone on board. Proper training of all personnel must provide an adequate knowledge and experience in effective casualty prevention. The EOCC manual has efficient, technically correct casualty control and prevention procedures. These procedures relate to all phases of an engineering plant. The EOCC documents possible casualties that may be caused by human error, material failure, or battle. The EOCC manual describes proven methods for the control of a casualty. It also provides information for prevention of further damage to the component, the system, or the engineering plant.

The EOCC manuals (books) are available at each watch station for self-indoctrination. The manuals contain documentation to assist engineering personnel in developing skills in controlling casualties to the ship's propulsion plant.

Skill in EOCC procedures is maintained through a well-administered training program. Primary training concentrates on the control of single-source casualties. These are casualties that may be attributed to the failure or malfunction of a single component or the failure of piping at a specific point in a system. Advanced training concentrates on controlling multiple casualties or on conducting a battle problem. An effective, well-administered watch-stander training program will contain, as a minimum, the following elements:

- Recognition of the symptoms
- Probable causes

- Probable effects
- Preventive actions that may be taken to reduce, eliminate, or control casualties

An EOSS package is not intended to be forgotten once it is developed and installed aboard a ship. It offers many advantages to the ship's operational readiness capabilities. It also provides detailed step-by-step sequencing of events for all phases of the engineering plant operation. Because it is work studied and system oriented, the EOSS provides the basic information for the optimum use of equipment and systems. It does this by specifying correct procedures tailored for a specific plant configuration.

The EOSS is not intended to eliminate the need for skilled plant operators. No program or system can achieve such a goal. The EOSS is a tool for better use of personnel and skills available. Although the EOSS is an excellent tool for shipboard training of personnel, it is primarily a working system for scheduling, controlling, and directing plant operations and casualty control procedures.

## **WATCH-STANDING DUTIES AND RESPONSIBILITIES**

As a Fireman, you maybe assigned to one of many different types of ships. On these ships, the engineering spaces vary in size and appearance. On a steam-driven ship, the boilers, the main engines, and their associated equipment may be in one space; or the boilers and their equipment may be in one space and the main engines and their equipment in another. Regardless of the number of boilers and main engines, the watches on most ships are basically the same. Therefore, this information is general in nature and does not apply to a specific class of ship.

When working with a variety of propulsion, auxiliary, and electrical equipment, you will stand various watches that range from main switchboards to security watches or other watches, depending on your ship's organization. When standing these watches, you will be required to perform many tasks. These include logging meter readings, inspecting equipment for leaks, and preventing fire hazards. This section has information on watches and duties that you may be required to perform. As you progress and become better acquainted with the fireroom and engine room, you will stand watches under the

supervision and instruction of a petty officer. You will learn to operate equipment using EOSS by following the ship's EOP and EOCC procedures.

In the following paragraphs we will discuss the EOOW, the watch stander from whom you will take your directions. We will also describe the various watches that pertain directly to you.

## **ENGINEERING OFFICER OF THE WATCH**

The EOOW is the officer on watch in charge of the main propulsion plant and of the associated auxiliaries. On some types of ships, the EOOW is normally a senior petty officer. The EOOW is primarily responsible for the safe and efficient performance of the engineering department watches (except damage control) associated with the equipment in his or her charge. The engineer officer determines if an officer or petty officer of the engineering department is qualified to perform the duties of the EOOW. When the engineer officer considers the officer or petty officer qualified in all respects, he or she assigns that person to the watch. The engineer officer or, in his or her absence, the MPA is authorized to direct the EOOW concerning the duties of the watch when such action is considered necessary.

## **DAMAGE CONTROL CENTRAL WATCH**

Damage control central (DCC) on most ships is manned around the clock when the ship is in port and under way. The DCC watch is responsible for the supervision and maintenance of the material condition of readiness in effect on the ship at all times. As a watch stander in DCC, you will be required to maintain the Damage Control Closure Log. You will also be responsible for the damage control log. On this log you will make entries of the firemain pressure, the number of pumps on the firemain, and several other entries. You will also make hourly status reports to the officer of the deck (OOD).

## **SOUNDING AND SECURITY**

As a Fireman, you will be required to stand sounding and security watches. While on this type of watch, you are the ship's first line of defense in maintaining watertight integrity. Your primary mission is to look for fire and flooding hazards. On some ships, this watch is set from the end of the working day until 0800 the next morning. It

is also in effect during holiday routine. The watch is particularly needed at these times because fewer personnel are working aboard the ship; certain spaces that require frequent observation are not under the normal observation of personnel working in or near them. On most ships, sounding and security watches are stood around the clock. When standing this watch, besides looking for fire and flooding hazards, you may take readings on the air-conditioning and refrigeration plants. You may also have to ensure no freshwater spigots are leaking or have been left running in heads, laundries, galleys, and pantries. Another of your responsibilities is to maintain the proper material readiness conditions by checking all watertight air ports, doors, hatches, scuttles, and other damage-control fittings. You must report any irregular condition (change in soundings, violations of material condition, fire hazards, and so forth) to your watch supervisor.

You will use a sounding tape to take soundings. The sounding tape is a steel tape coiled on a reel suitable for being held while the tape is lowered. The tape is weighted at the end so that it can be lowered into the sounding tube.

When taking a sounding, you will notice that water is relatively hard to see on a brass or bronze sounding rod. If you have problems reading the level, dry the rod or tape thoroughly and coat it with white chalk or indicating paste before you take a sounding. When the chalk becomes wet, it turns to a light-brown color. For example, if there are 6 inches of water in a tank when you take a sounding, the light-brown color of the chalk will be distinctly visible up to the 6-inch mark. The remainder of the sounding rod will still be covered with the white chalk.

**NOTE:** The chalk method is used only where water may be present. Water-indicating paste will not change color with fuel oil and is often used by the oil king to determine if there is water at the bottom of a fuel tank. Always remember never to use the same sounding tape in a fresh water tank sounding that had been used for fuel, oil, or any other purpose other than fresh water.

## **MESSENGER OF THE WATCH**

The messenger of the watch performs a number of important duties that involve great responsibility. The messenger is usually assigned as the sound-powered telephone talker. This occurs when the ship is undergoing close maneuvering conditions with other ships, entering

or leaving port, or refueling or replenishing from another ship. Since the sound-powered telephones provide communications between all the engineering spaces, you must know the proper procedures. When you talk, speak slowly and distinctly. Pronounce the syllables of each word very clearly. When you receive a message, or are given a message to transmit, repeat it word for word, exactly as it was given to you. Do not engage in any idle chatter.

As the messenger of the watch, you will also perform other duties as assigned by the petty officer of the watch. These duties include checking operating machinery and recording temperature and pressure readings in the appropriate logs.

The operating log is an hourly record of operating pressures and temperatures of almost all operating machinery. The log readings include lube oil and boiler pressures and temperatures, pump suction and discharge pressures, and other items needed to operate the engineering plant. You will have to write and print legibly. You also have to spell common Navy terms correctly and maintain your logs neatly and accurately. You should know the proper operating and limiting or danger pressures and temperatures of your equipment. This allows you to know when a piece of machinery or equipment is not operating properly.

### **COLD-IRON WATCH**

When a ship stops operating its own plant and is receiving services from shore or other ships, the ship is considered to be in a cold iron status. A security and fire watch is usually set by each department. This watch is called the cold-iron watch.

Each cold-iron watch makes frequent inspections of the assigned area and looks for fire hazards, flooding, or other unusual conditions throughout the area. The watch sees that no unauthorized persons are in the watch area; that all spaces are cleaned; and that no tools, rags, gear, and the like are left adrift. The watch also keeps the bilges reasonably free of water. (**NOTE:** You must get permission to pump water from the duty engineer officer and the OOD.)

The watch makes hourly reports to the OOD or the DCC watch on all existing conditions. Any unusual conditions are reported to the OOD or DCC immediately. They can notify the department responsible to take the necessary corrective measures.

When hot work is done in the watch area, the cold-iron watch ensures that a fire watch is stationed. The fire watch stands by with a CO<sub>2</sub> extinguisher. If a fire watch has not been stationed, the cold-iron watch stops all work until a fire watch can be stationed. The cold-iron watch then carries out all pertinent orders.

If the ship is in dry dock, the cold-iron watch will check all sea valves after working hours. This is to ensure that the valves are secure or blanked off. The cold-iron watch also ensures that no oil is pumped into the dry docks at any time. The watch will not allow any weights, such as fuel oil or feedwater, to be shifted without permission of the engineer officer or DCA.

### **BURNERMAN**

The burnerman is responsible for cutting burners "in" and "out" as directed by the boiler technician of the watch (BTOW). The burnerman must keep a close check for dirty atomizers and change them when authorized by the BTOW. The burnerman must always be assisted by another watch stander when lighting fires or cutting in additional burners. This procedure will ensure that fires are safely lit and are burning properly, that no fuel leaks, and that fires can be quickly secured if a casualty occurs.

### **CHECKMAN/UPPER-LEVEL WATCH**

On ships that do not have automatic feedwater controls, the checkman is responsible for operating the feed check valve and maintaining the proper water level in the steam drum. This is the checkman's only responsibility. On ships that have automatic feedwater controls, a checkman is not needed unless the control is shifted from automatic to manual. The responsibilities of the upper-level watch include (1) the operation of the forced draft blowers, deaerating feed tank, and all boiler-related equipment on the upper level; (2) surface blowing; (3) starting and stopping machinery; (4) opening and closing valves; (5) monitoring gauges; and (6) aligning systems.

### **FIREROOM LOWER-LEVEL**

The fireroom watch is responsible for starting, stopping, and maintaining proper levels and pressures on all boiler-related equipment on the lower level. This equipment will normally include the main feed booster pumps and the fuel oil

service pumps. The fireroom watch may also assist the burnerman in lighting fires in the boiler. This watch may also assist in shifting suction tanks on fuel oil, fresh water, feedwater, and shifting cooling water strainers and fuel oil strainers.

## **THROTTLE WATCH**

The tasks of a throttleman at the main engines are critical. Orders from the bridge concerning the movement of the propellers must be complied with immediately. To make correct adjustments for the required speed, you must keep a close watch on the revolutions-per-minute (rpm) indicator on the throttle board. You have to open or close the throttle, as required, to achieve or maintain the necessary rpm. Besides handling the throttle itself, you may also have to operate a variety of associated valves; accurately log all speed changes in the Engineer's Bell Book; visually check all gauges (pressure, temperature, vacuum, and so forth) installed on the throttle board; and keep the petty officer in charge informed of any abnormal gauge readings.

You should become thoroughly familiar with all the gauges, instruments, and indicators on the throttle board to know what the normal readings are. Some of these include the steam, feedwater, and cooling water pressure gauges, steam temperature thermometers, the rpm indicator, the EOT, gauges indicating the vacuum obtained in the main engine low-pressure turbine, and others. Whenever an opportunity presents itself, study the throttle board and ask questions. Do not hesitate to ask the operator which readings are normal. Ask which readings are appropriate for steaming conditions. After learning the difference between a normal reading and an abnormal reading, you will be able to help prevent a major casualty. You will recognize an abnormal reading and can report it to the petty officer in charge of the watch.

## **ENGINE ROOM UPPER-LEVEL WATCH**

When you are assigned to the duties of the upper-level watch in the engine room, you will have to perform the following tasks:

- Record periodic temperature and pressure readings from various gauges on, or connected to, the upper-level machinery.
- Make required valve adjustments to correct conditions indicated by slight

variations from the normal readings, and report unusual conditions to the petty officer in charge.

- Maintain a normal water level in the deaerating tank, if it is located in the engine room, by adjusting the excess and makeup feed valves.
- Light off and secure turbogenerators and other upper-level machinery, as ordered.
- Maintain an adequate gland seal pressure on the turbogenerator.

## **ENGINE ROOM LOWER-LEVEL WATCH**

You will be assigned to the engine room lower level to assist the lower-level watch (pumpman). You will be involved with a number of pumps and other auxiliary machinery. Some of the pumps and equipment with which you will work are the main lube oil pumps and lube oil coolers; the main condensate pumps and main condenser; the main feed pumps; the main feed booster pumps; the fire pumps; and when they are installed in the engine room, air compressors.

Besides learning the proper procedures for starting, operating, and stopping the pumps and equipment, you must make various checks of the operating machinery. Some of the checks for the main feed pump, the lube oil pump, and the main condensate pump are described in the sections that follow.

### **Main Feed Pump**

You will have to comply with the posted instructions and safety precautions for the machinery and equipment at the main feed pump station. When assisting the pumpman, you will also perform the following duties:

- Maintain the main feed pump discharge pressure at a predetermined value by adjusting the constant pressure governor.
- Keep the main feed pump bearings at the proper temperature by regulating the flow of water through the feed pump lube oil cooler.
- Check to ensure the lube oil pressure to the bearings is correct.

- Keep the shaft packing glands adjusted properly. A small amount of leakage is necessary to prevent burning out the packing, but excessive leakage wastes boiler feedwater.
- Check and maintain the proper lube oil level in the main feed pump sump tank.
- Keep the valve packing glands tightened to prevent leakage.
- Keep the watch station clean; remove fire hazards by wiping up oil and picking up rags and other stray gear.
- Keep alert for unusual sounds, vibrations, temperatures, and pressures from operating equipment.
- Keep the standby pump ready for instant use.

### **Lube Oil Pump**

The following are duties you will perform while assisting the pumpman at the lube oil pump station:

- Maintain the proper lube oil pump discharge pressure and the proper lube oil temperature.
- Keep the standby pump on automatic standby.
- Shift and clean the main lube oil strainers at least once each watch.
- Check the lube oil system for leaks, and maintain the proper oil level in the main engine sump tank.
- Operate the lube oil purifier as directed.
- Regulate the cooling water flow through the lube oil cooler to maintain the correct oil outlet temperature.

### **Main Condensate Pump**

The following are duties you will perform while assisting the pumpman at the main condensate pump station:

- Keep the condensate in the condenser hot well at the proper level.

- Frequently check the exhaust trunk and main condenser overboard for abnormal temperatures.
- Check the main condensate pump bearings for proper oil pressure and temperature.
- Start or secure an additional pump, as required, to keep the condensate level at the correct height.
- Constantly check for unusual conditions (vibrations, sounds, and high or low temperatures or pressures) of operating equipment.

All watch standers should be constantly alert for signs of leakage in all parts of the steam and water systems. The following are some of the more common causes of feedwater waste:

- Leaks in pipe fittings, flanges, valve and pump packing glands, pump housings, and relief valves
- Excessive gland sealing steam

Remember, a poorly operated plant reflects on the ability of the watch stander.

### **SHAFT ALLEY WATCH**

Another main engine duty is that of keeping watch on the bearings of the propeller shafts leading from the reduction gears (or motors of a turboelectric-driven ship) to the ship's propellers. As a shaft alley watch stander, you may perform the following duties:

- Check all spring bearings for proper lubrication. This includes correct oil level, condition of the oil, proper operation of self-oiling devices (ring or chain), and bearing temperature.
- Check and adjust the stern tube gland for the correct amount of leak-off.
- Pump the shaft alley bilge, as authorized by the EOW and OOD.
- During high speed, keep alert and observe any abnormal rise in bearing temperature.
- Report hourly, by phone, to the control engine room under normal conditions and if abnormal conditions develop.
- Operate the main thrust bearing when it is located in the shaft alley.



## EVAPORATOR WATCH

A ship requires a large amount of pure fresh water daily for use as boiler feedwater, for corrosion control (freshwater wash down), and for the crew's consumption. However, a ship can only store enough water to last a few days. Therefore, proper and careful watches must be maintained on the evaporators whenever they are in operation. An evaporator watch has to constantly check on pressures, temperatures, vacuum, and salt content of the distilled water. A ship cannot operate if the distilled water for feedwater contains more than the maximum allowable amount of salt.

## WATCH, QUARTER, AND STATION BILL

Each division officer prepares a watch, quarter, and station bill for his or her division. You will generally find the following information on this bill:

- Organization of the division (sections and watches).
- A listing of each person as to billet number, locker number, bunk number, compartment number, name, rating, and rate (actual and allowance).
- Watch assignments for each person under various conditions of battle readiness.
- The station and job each person will have in emergency situations, such as fire, rescue and assistance, and general emergency.

- The special duties and stations each person will have. The special duties may include visit and search party, landing force, special sea detail, and other special duties.

The watch, quarter, and station bill tells you where you fit into the ship's organizational picture. Check it frequently; it is your duty to know where you belong under all conditions. **THERE IS NO EXCUSE FOR NOT KNOWING.** The bills may be designed differently for different ships, but the stations and duties are always about the same. The bill assignments are for actual emergencies and drills. Billets are assigned according to the skills and the qualifications of the personnel in the division. Refer to *Basic Military Requirements*, NAVEDTRA 10054-F, for more information about the watch, quarter, and station bill.

## SUMMARY

This chapter has covered information on standard ship and engineering organization and engineering administration, ratings, and programs, such as safety, PMS, tag-out, and EOSS. You have learned about the various watches of the engineering department. Do not become overwhelmed by the many things you must learn to be an effective watch stander. Keep your ears and eyes open, and above all, ASK QUESTIONS. If you desire to advance in the Navy, you should study the publications mentioned in the *Advancement Handbook for Apprenticeships*, NAVEDTRA 71700, and the *Advancement Handbook for Petty Officers* (the NAVEDTRA number is rate specific; ask your division training officer for assistance).



## CHAPTER 2

# ENGINEERING FUNDAMENTALS

You are about to become acquainted with the fascinating world of PHYSICS. You will learn about the various natural and physical laws and phenomena. Physics is concerned with those aspects of nature which can be understood in a fundamental way in terms of elementary principles and laws. The forces of physics and the laws of nature are at work in every piece of machinery and equipment. It is by these forces and laws that the machinery and equipment produce work.

In the following paragraphs you will learn about matter, magnetism, electricity, motion, properties of mass, temperature, pressure, various laws and principles of physics dealing with motion, gases, hydraulics and pneumatics, and basic information on metals. After studying this chapter, you will have the fundamental, basic knowledge to understand what electrical and mechanical devices are all about and how they work.

### MATTER

If western science has roots, they probably lie in the rubble that was once ancient Greece. Except for the Greeks, ancient people had little interest in the structure of materials. They accepted a solid as being just that—a continuous, uninterrupted substance. One Greek school of thought believed that if a piece of matter, such as copper, were subdivided, it could be subdivided indefinitely and still only that material would be found. Others reasoned that a limit exists to the number of subdivisions that could be made and have the material still retain its original characteristics. They held fast to the idea that all substances are built upon a basic particle. Experiments have revealed that, indeed, several basic particles, or building blocks, are within all substances.

Matter cannot be created nor destroyed. This law holds within the experimental error of the

most precise chemical reactions. This theory of the conservation of energy will be discussed later in this chapter. Matter is defined as anything that occupies space and has weight; that is, the weight and dimensions of matter that can be measured. Examples of matter are air, water, clothing, and even our own bodies. So, we can say matter is found in any one of three states: GASEOUS, LIQUID, and SOLID.

In the following paragraphs we will describe how substances are classified as elements and compounds and how they are made up of molecules and atoms. We will then learn about protons, electrons, and the physics of electricity.

### ELEMENTS AND COMPOUNDS

An element is a substance that cannot be reduced to a simpler substance by chemical means. Examples of elements with which you are in every day contact are iron, gold, silver, copper, and oxygen. Over 100 known elements are in existence. All the different substances we know about are composed of one or more of these elements.

When two or more elements are chemically combined, the resulting substance is called a COMPOUND. A compound is a chemical combination of elements that can be separated by chemical means. Examples of common compounds are water, which consists of hydrogen and oxygen, and table salt, which consists of sodium and chlorine. A MIXTURE, on the other hand, is a combination of elements and compounds, not chemically combined, that can be separated by physical means. Examples of mixtures are air, which is made up of nitrogen, oxygen, carbon dioxide, and small amounts of rare gases, and sea water, which consists chiefly of salt and water.

### MOLECULES

A MOLECULE is a chemical combination of two or more atoms, (atoms are described in the

next paragraph). In a compound the molecule is the smallest part that has all the characteristics of the compound. Consider water, for example. Depending on the temperature, it may exist as a liquid (water), a solid (ice), or a gas (steam). Regardless of the temperature, it will still have the same composition. If we start with a quantity of water, divide this and pour out one half, and continue this process enough times, we will end up with a quantity of water that cannot be further divided without ceasing to be water. This quantity is called a molecule of water. If this molecule of water is divided, instead of two parts of water, we will have one part of oxygen and two parts of hydrogen (H<sub>2</sub>O).

## ATOMS

Molecules are made up of smaller particles called ATOMS. An atom is the smallest particle of an element that retains the characteristics of that element. The atom of one element, however, differs from the atoms of all other elements. Since over 100 elements are known, there must be over 100 different atoms, or a different atom for each element. Just as thousands of words are made by a combination of the proper letters of the alphabet, so thousands of different materials are made by the chemical combination of the proper atoms. Any particle that is a chemical combination of two or more atoms is called a molecule. The oxygen molecule has two atoms of oxygen, and the hydrogen molecule has two molecules of hydrogen. Sugar, on the other hand,

is a compound composed of atoms of carbon, hydrogen, and oxygen. These atoms are combined into sugar molecules. Since the sugar molecules can be broken down by chemical means into smaller and simpler units, we cannot have sugar atoms.

In figure 2-1 you will see that the atoms of each element are made up of electrons, protons, and, in most cases, neutrons, which are collectively called subatomic particles. Furthermore, the electrons, protons, and neutrons of one element are identical to those of any other element. The reason there are different elements is that the number and arrangement of electrons and protons within the atom are different for the different elements.

The electron is considered to be a small negative charge of electricity. The proton has a positive charge of electricity equal and opposite to the charge of the electron. Scientists have measured the mass and size of the electron and proton. They know how much charge each has. The electron and proton each have the same quantity of charge, although the mass of the proton is about 1837 times that of the electron. In some atoms, a neutral particle exists called a neutron. The neutron is a mass about equal to that of a proton, but it has no electrical charge. According to a popular theory, the electrons, protons, and neutrons of the atoms are thought to be arranged in a manner similar to a miniature solar system. The protons and neutrons form a heavy nucleus with a positive charge, around which the very light electrons revolve.

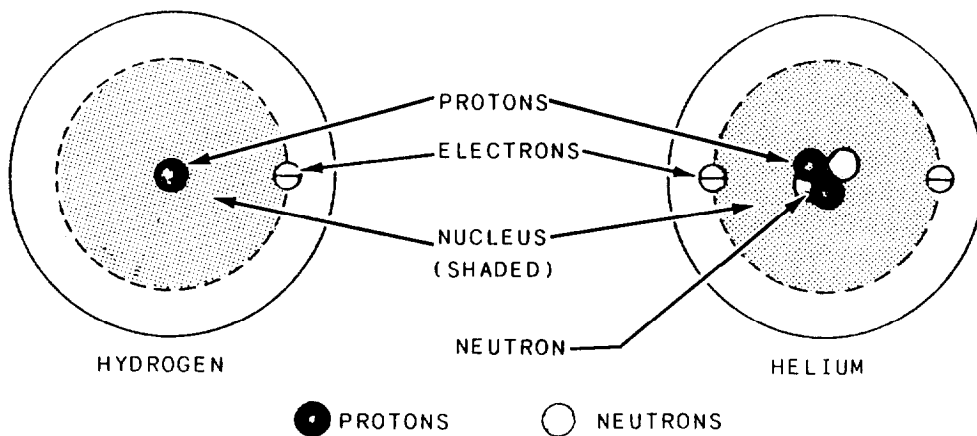

Figure 2-1.—Structure of simple atoms.

Figure 2-1 shows one hydrogen and one helium atom. Each has a relatively simple structure. The hydrogen atom has only one proton in the nucleus with one electron rotating about it. The helium atom is a little more complex. It has a nucleus made up of two protons and two neutrons, with two electrons rotating about the nucleus. Elements are classified numerically according to the complexity of their atoms. The atomic number of an atom is determined by the number of protons in its nucleus.

In a neutral state, an atom contains an equal number of protons and electrons. Therefore, an atom of hydrogen, which contains one proton and one electron, has an atomic number of 1; and helium, with two protons and two electrons, has an atomic number of 2. The complexity of atomic structure increases with the number of protons and electrons.

## MAGNETISM

To understand properly the principles of how electrical equipment produces work, you must understand magnetism, the effects of magnetism on electrical equipment, and the relationship of the different properties of electricity. Magnetism and electricity are so closely related that the study of either subject would be incomplete without at least a basic knowledge of the other.

Much of today's electrical and electronic equipment could not function without magnetism. Computers, tape recorders, and video reproduction equipment use magnetic tape. High fidelity speakers use magnets to convert amplifier outputs into audible sound. Electric motors use magnets to convert mechanical motion into electrical energy. Magnetism is generally defined as that property of a material that enables it to attract pieces of iron. Material with this property is known as **MAGNETIC**. The word *magnetic* originated from the ancient Greeks, who found stones possessing this characteristic. Materials that are attracted by a magnet, such as iron, steel, nickel, and cobalt, have the ability to become magnetized. Thus they are magnetic materials. Materials, such as paper, wood, glass, or tin, which are not attracted by magnets, are considered nonmagnetic. Nonmagnetic materials

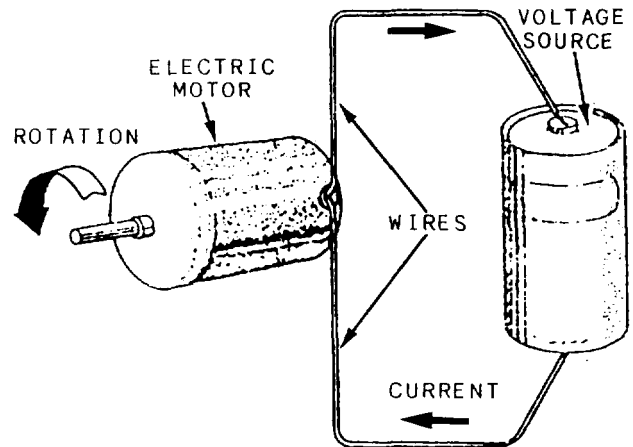

Figure 2-2.—The effect of current.

are not able to become magnetized. You will find additional information on the basic principles of magnetism in the Navy Electricity and Electronics Training Series (NEETS), module 1, NAVED-TRA 172-01-00-88, chapter 1.

## ELECTRICITY

Electricity is a combination of a force called **VOLTAGE** and the movement of invisible particles known as **CURRENT**. The force of voltage can be compared to the force generated by a water pump, which moves water through a distribution system, generally an arrangement of pipes. Voltage is the force that causes current to flow through a system of wires. Current is the movement of invisible particles that causes electrical devices to operate. We cannot see current, but we can determine its presence by the effects it produces. Figure 2-2, for example, shows the effect of current. It shows how the voltage force from a battery causes electrical current to flow through wires and an electrical motor. The current is invisible, but it produces the effect of making the motor run. Current flows through the wires much the same way as water flows through pipes.

Current consists of electrons, which are invisible atomic particles. Voltage is the force that causes current, in the form of electrons, to move through wires and electrical devices. However, one important difference between current in wires and water in pipes is that water can flow out of a

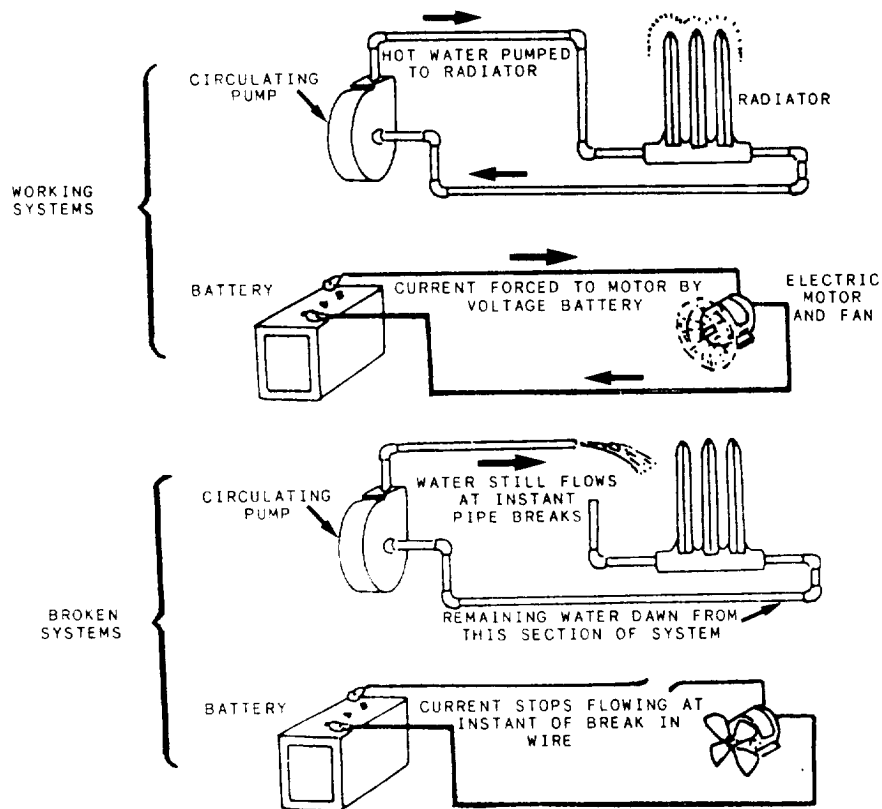

Figure 2-3.—Different characteristics of current and water.

broken pipe, but current cannot flow out of a broken wire. When a wire is broken, the force of the voltage is removed from the motor, as shown in figure 2-3. The circulating pump in the working system creates a force that moves hot water through the pipes and radiator. The battery creates a force that moves current through the wires and causes the motor to run. The wire and pipe are broken open in the broken system. In these instances, the circulating pump forces water to flow out of the pipe, but even though the battery still creates a voltage force, current does not flow out of the wire. You will find additional information on the basic principles of electricity in the NEETS, module 1, NAVEDTRA 172-01-00-88, chapter 1.

resistance. This relationship is called Ohm's law and is stated as follows:

$$I = E/R,$$

where: I = current in amperes,

E = voltage in volts, and

R = resistance in ohms.

As stated in Ohm's law, current is inversely proportional to resistance. This means, as the resistance in a circuit increases, the current decreases proportionately. In the equation  $I = E/R$ , if any two quantities are known, the third one can be determined.

## OHM'S LAW

In the early part of the 19th century, George Simon Ohm proved by experiment that a precise relationship exists between current, voltage, and

## NEWTON'S LAWS

Sir Isaac Newton was an English philosopher and mathematician who lived from 1642 to 1727 A.D. He was the formulator of the basic laws of

modern philosophy concerning gravity and motion. Before we discuss motion and other related factors, you should be familiar with Newton's laws. These laws are the bases for the theories of physics that we describe in the following sections.

### NEWTON'S FIRST LAW

Newton's first law states that a body at rest tends to remain at rest. A body in motion tends to remain in motion. This law can be demonstrated easily in everyday use. For example, a parked automobile will remain motionless until some force causes it to move—a body at rest tends to remain at rest. The second portion of the law—a body in motion tends to remain in motion—can be demonstrated only in a theoretical sense. The same car placed in motion would remain in motion (1) if all air resistance were removed, (2) if no friction were in the bearings, and (3) if the surface were perfectly level.

### NEWTON'S SECOND LAW

Newton's second law states that an imbalance of force on a body tends to produce an acceleration in the direction of the force. The acceleration, if any, is directly proportional to the force. It is inversely proportional to the mass of the body. This law can be explained by throwing a common softball. The force required to accelerate the ball to a rate of 50 ft/sec<sup>2</sup> would have to be doubled to obtain an acceleration rate of 100 ft/sec<sup>2</sup>. However, if the mass of the ball were doubled, the original acceleration rate would be cut in half. You would have 50 ft/sec<sup>2</sup> reduced to 25 ft/sec<sup>2</sup>.

### NEWTON'S THIRD LAW

Newton's third law states that for every action there is an equal and opposite reaction. You have demonstrated this law if you have ever jumped from a boat up to a dock or a beach. The boat moved opposite to the direction you jumped. The recoil from firing a shotgun is another example of action-reaction. Figure 2-4 depicts these examples.

In an airplane, the greater the mass of air handled by the engine, the more it is accelerated by the engine. The force built up to thrust the plane forward is also greater. In a gas turbine,

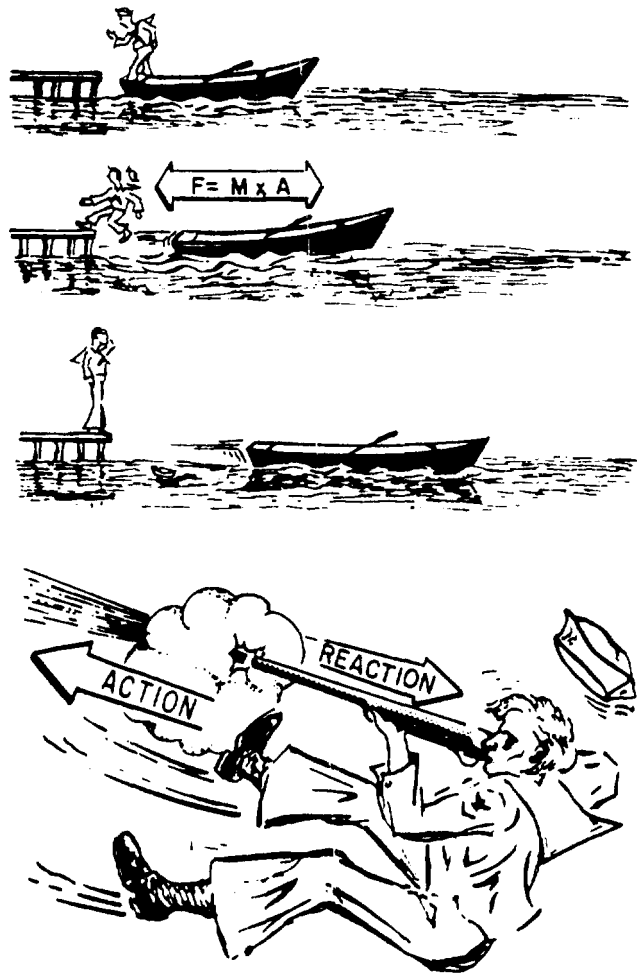

Figure 2-4.—Newton's third law of motion.

the thrust velocity can be absorbed by the turbine rotor and converted to mechanical energy. This is done by the addition of more and progressively larger power turbine wheels.

### SPEED, VELOCITY, AND ACCELERATION

SPEED is defined as the distance covered per unit of time, such as a car traveling at 60 mph. VELOCITY is speed in a certain direction, such as a car traveling due north at 60 mph. ACCELERATION is the rate at which velocity increases. If, for example, the propeller shaft rate of rotation increases from stop to 100 rpm in 20 minutes, the acceleration is 5 rpm per minute. In other words, the velocity has increased 5 revolutions per minute, during each minute, for a total period of 20 minutes. A body moving at

a constant speed has no acceleration. When the velocity of an object increases by the same amount each second or minute, you have uniform acceleration. Uniform deceleration is when the decrease in velocity is the same each second or minute.

### **MASS, WEIGHT, FORCE, AND INERTIA**

Very few terms are used in physics with greater frequency and assurance than mass, and few are more difficult to define. Mass is often confused with weight. This is a mistake not helped since the unit of measurement for both mass and weight is the gram. The **MASS** of an object is the quantity of matter that the object contains. The **WEIGHT** of the object is equal to the gravitational force with which the object is attracted to the earth. **FORCE** is what makes an object start to move, speed up, slow down, or keep moving against resistance. Force may be either a push or a pull. You exert a force when you push against a truck, whether you move the truck or only try to move it. You also exert a force when you pull on a heavy piano, whether you move the piano or only try to move it. Forces can produce or prevent motion.

A tendency to prevent motion is the frictional resistance offered by an object. This frictional resistance is called frictional force. While it can never cause an object to move, it can check or stop motion. Frictional force wastes power, creates heat, and causes wear. Although frictional force cannot be entirely eliminated, it can be reduced with lubricants.

**INERTIA** is the property that causes objects at rest to remain at rest and objects in motion to remain in motion until acted upon by an outside force. An example of inertia is one body that has twice as much mass as another body of the same material offering twice as much force in opposition to the same acceleration rate.

Inertia in a body depends on its motion. The physical principles of mass and inertia are involved in the design and operation of the heavy machinery that is to be placed into motion, such as an engine's flywheel and various gears that are at work in the ship's engineering plant. The great mass of the flywheel tends to keep it rotating once it has been set in motion. The high inertia of the flywheel keeps it from responding to small fluctuations in speed and thus helps keep the engine running smoothly.

### **ENERGY**

Can you define energy? Although everyone has a general idea of the meaning of energy, a good definition is hard to find. Most commonly, perhaps, energy is defined as the capacity for doing work. This is not a very complete definition. Energy can produce other effects which cannot possibly be considered work. For example, heat can flow from one object to another without doing work; yet heat is a form of energy, and the process of heat transfer is a process that produces an effect. A better definition of energy, therefore, states that energy is the capacity for producing an effect.

Energy exists in many forms. For convenience, we usually classify energy according to the size and nature of the bodies or particles with which it is associated. Thus we say that **MECHANICAL ENERGY** is the energy associated with large bodies or objects—usually, things that are big enough to see. **THERMAL ENERGY** is energy associated with molecules. **CHEMICAL ENERGY** is energy that arises from the forces that bind the atoms together in a molecule. Chemical energy is demonstrated whenever combustion or any other chemical reaction takes place. Electrical energy (light, X rays, and radio waves) is associated with particles that are even smaller than atoms.

Mechanical energy, thermal energy, and chemical energy must also be classified as being either stored energy or energy in transition.

**STORED ENERGY** can be thought of as energy that is actually contained in or stored in a substance or system. There are two kinds of stored energy: (1) potential energy and (2) kinetic energy. When energy is stored in a substance or system because of the relative **POSITIONS** of two or more objects or particles, we call it potential energy. When energy is stored in a substance or system because of the relative **VELOCITIES** of two or more objects or particles, we call it kinetic energy.

Mechanical energy in transition is called work. Thermal energy in transition is called heat. In the next section we will discuss mechanical and thermal energy and energy transformations.

If you do not completely understand this classification, come back to it from time to time as you read the following sections on mechanical energy and thermal energy. The examples and discussion given in the following sections will probably help you understand this classification.



## MECHANICAL ENERGY

Let's consider the two stored forms of mechanical energy. Mechanical POTENTIAL energy exists because of the relative positions of two or more objects. For example, a rock resting on the edge of a cliff in such a position that it will fall freely if pushed has mechanical potential energy. Water at the top of a dam has mechanical potential energy. A sled that is being held at the top of an icy hill has mechanical potential energy.

Mechanical KINETIC energy exists because of the relative velocities of two or more objects. If you push that rock, open the gate of the dam, or let go of the sled, something will move. The rock will fall; the water will flow; the sled will slide down the hill. In each case the mechanical potential energy will be changed to mechanical kinetic energy. Another way of saying this is that the energy of position will be changed to the energy of motion.

In these examples, you will notice that an external source of energy is used to get things started. Energy from some outside source is required to push the rock, open the gate of the dam, or let go of the sled. All real machines and processes require this kind of boost from an energy source outside the system. For example, a tremendous amount of chemical energy is stored in fuel oil; but this energy will not turn the power turbine until you have expended some energy to start the oil burning. Similarly, the energy in any one system affects other energy systems. However, it is easier to learn the basic principles of energy if we forget about all the energy systems that might be involved in or affected by each energy process. In the examples given in this chapter, therefore, we will consider only one energy process or energy system at a time, disregarding both the energy boosts that may be received from outside systems and the energy transfers that may take place between the system we are considering and other systems.

Notice that both mechanical potential energy and mechanical kinetic energy are stored forms of energy. It is easy to see why we regard mechanical potential energy as being stored, but it is not so easy to see the same thing about mechanical kinetic energy. Part of the trouble comes about because mechanical kinetic energy is often referred to as the energy of motion, thus leading to the false conclusion that energy in transition is somehow involved. This is not the case, however. Work is the only form of

mechanical energy that can be properly considered as energy in transition.

If you have trouble with the idea that mechanical kinetic energy is stored, rather than in transition, think of it like this: A bullet that has been fired from a gun has mechanical kinetic energy because it is in motion. The faster the bullet is moving, the more kinetic energy it has. There is no doubt in anybody's mind that the bullet has the capacity to produce an effect, so we may safely say that it has energy. Although the bullet is not in transition, the energy of the bullet is not transferred to any other object or system until the bullet strikes some object that resists its passage. When the bullet strikes against a resisting object, then, and only then, can we say that energy in transition exists, in the form of heat and work.

In this example, we are ignoring the fact that some work is done against the resistance of the air and that some heat results from the passage of the bullet through the air. But this does not change the basic idea that kinetic energy is stored energy rather than energy in transition. The air must be regarded as a resisting object, which causes some of the stored kinetic energy of the bullet to be converted into energy in transition (heat and work) while the bullet is passing through the air. However, the major part of the stored kinetic energy does not become energy in transition until the bullet strikes an object firmer than air that resists its passage.

Mechanical potential energy is measured in foot-pounds (ft-lb). Consider, for example, the rock at the top of the cliff. If the rock weighs 5 pounds and if the distance from the rock to the earth at the base of the cliff is 100 feet, 500 ft-lb of mechanical potential energy exists because of the relative positions of the rock and the earth. Another way of expressing this idea is by the following formula:

$$P E = W \times D ,$$

where:

PE = total potential energy of the object  
(in ft-lb),

W = total weight of the object (in  
pounds), and

D = distance between the earth and the  
object (in feet).

Mechanical kinetic energy is also measured in ft-lb. The amount of kinetic energy present at any one time is directly related to the velocity of the moving object and to the weight of the moving object.

Mechanical potential energy can be changed into mechanical kinetic energy. If you push that 5-pound rock over the edge of the 100-foot cliff, it begins to fall, and as it falls, it loses potential energy and gains kinetic energy. At any given moment, the total mechanical energy (potential plus kinetic) stored in the system is the same—500 ft-lb. But the proportions of potential energy and kinetic energy are changing all the time as the rock is falling. Just before the rock hits the earth, all the stored mechanical energy is kinetic energy. As the rock hits the earth, the kinetic energy is changed into energy in transition—that is, work and heat.

Mechanical kinetic energy can likewise be changed into mechanical potential energy. For example, suppose you throw a baseball straight up in the air. The ball has kinetic energy while it is in motion, but the kinetic energy decreases and the potential energy increases as the ball travels upward. When the ball has reached its uppermost position, just before it starts its fall back to earth, it has only potential energy. Then, as it falls back toward the earth, the potential energy is changed into kinetic energy again.

Mechanical energy in transition is called WORK. When an object is moved through a distance against a resisting force, we say that work has been done. The formula for calculating work is

$$W = F \times D ,$$

where:

W = work,

F = force, and

D = distance.

As you can see from this formula, you need to know how much force is exerted and the distance through which the force acts before you can find how much work is done. The unit of force is the pound. When work is done against gravity, the force required to move an object is equal to the weight of the object. Why? Because weight is a measure of the force of gravity or, in other words, a measure of the force of attraction

between an object and the earth. How much work will you do if you lift that 5-pound rock from the bottom of the 100-foot cliff to the top? You will do 500 ft-lb of work—the weight of the object (5 pounds) times the distance (100 feet) that you move it against gravity.

We also do work against forces other than the force of gravity. When you push an object across the deck, you are doing work against friction. In this case, the force you work against is not only the weight of the object, but also the force required to overcome friction and slide the object over the surface of the deck.

Notice that mechanical potential energy, mechanical kinetic energy, and work are all measured in the same unit, ft-lb. One ft-lb of work is done when a force of 1 pound acts through a distance of 1 foot. One ft-lb of mechanical potential energy or mechanical kinetic energy is the amount of energy that is required to accomplish 1 ft-lb of work.

The amount of work done has nothing at all to do with how long it takes to do it. When you lift a weight of 1 pound through a distance of 1 foot, you have done 1 ft-lb of work, regardless of whether you do it in half a second or half an hour. The rate at which work is done is called POWER. The common unit of measurement for power is the HORSEPOWER (hp). By definition, 1 hp is equal to 33,000 ft-lb of work per minute or 550 ft-lb of work per second. Thus a machine that is capable of doing 550 ft-lb of work per second is said to be a 1-hp machine. (As you can see, your horsepower rating would not be very impressive if you did 1 ft-lb of work in half an hour. Figure it out. It works out to be just a little more than one-millionth of a horsepower. )

## THERMAL ENERGY

Earlier in this chapter we discussed molecules. You should remember that all substances are composed of very small particles called molecules. The energy associated with molecules is called thermal energy. Thermal energy, like mechanical energy, exists in two stored forms and in one transitional form. The two stored forms of thermal energy are (1) internal potential energy and (2) internal kinetic energy. Thermal energy in transition is called HEAT.

Although molecules are too small to be seen, they behave in some ways pretty much like the larger objects we considered in the discussion of mechanical energy. Molecules have energy of position (internal potential energy) because of the

forces that attract molecules to each other. In this way, they are somewhat like the rock and the earth we considered before. Molecules have energy of motion (internal kinetic energy) because they are constantly in motion. Thus, the two stored forms of thermal energy—internal potential energy and internal kinetic energy—are in some ways similar to mechanical potential energy and mechanical kinetic energy, except everything is on a smaller scale.

For most purposes, we will not need to distinguish between the two stored forms of thermal energy. Therefore, instead of referring to internal potential energy and internal kinetic energy, from now on we will simply use the term *internal energy*. By internal energy, then, we will mean the total of all internal energy stored in the substance or system because of the motion of the molecules and because of the forces of attraction between molecules. Although the term may be unfamiliar to you, you probably know more about internal energy than you realize. Because molecules are constantly in motion, they exert a pressure on the walls of the pipe, cylinder, or other object in which they are contained. Also, the temperature of any substance arises from, and is directly proportional to, the activity of the molecules. Therefore, every time you read thermometers and pressure gauges you are finding out something about the amount of internal energy contained in the substance. High pressures and temperatures indicate that the molecules are moving rapidly and that the substance therefore has a lot of internal energy.

*Heat* is a more familiar term than internal energy, but may actually be more difficult to define correctly. The important thing to remember is that heat is THERMAL ENERGY IN TRANSITION—that is, it is thermal energy that is moving from one substance or system to another.

An example will help to show the difference between heat and internal energy. Suppose there are two equal lengths of pipe made of identical materials and containing steam at the same pressure and temperature. One pipe is well insulated; the other is not insulated at all. From everyday experience you know that more heat will flow from the uninsulated pipe than from the insulated pipe. When the two pipes are first filled with steam, the steam in one pipe contains exactly as much internal energy as the steam in the other pipe. We know this is true because the two pipes contain equal volumes of steam at the same pressure and at the same temperature. After

a few minutes, the steam in the uninsulated pipe will contain much less internal energy than the steam in the insulated pipe, as we can tell by measuring the pressure and the temperature of the steam in each pipe. What has happened? Stored thermal energy—internal energy—has moved from one system to another, first from the steam to the pipe, then from the uninsulated pipe to the air. This MOVEMENT or FLOW of thermal energy from one system to another is called heat.

A good deal of confusion exists concerning the use of the word *heat*. For example, you will hear people say that a hot object contains a lot of heat when they really mean that it contains a lot of internal energy. Or you will hear that heat is added to or removed from a substance. Since heat is the FLOW of thermal energy, it can no more be added to a substance than the flow of water could be added to a river. (You might add water, and this addition might increase the flow, but you could hardly say that you added flow.) The only thermal energy that can in any sense be added to or removed from a substance is INTERNAL ENERGY.

## ENERGY TRANSFORMATIONS

The machinery and equipment in the engineering plant aboard ship are designed either to carry energy from one place to another or to change a substance from one form to another. The principles of energy transformations and some of the important energy changes that occur in the shipboard propulsion cycle are discussed in the following paragraphs.

### Conservation of Energy

The basic principle dealing with the transformation of energy is the PRINCIPLE OF THE CONSERVATION OF ENERGY. This principle can be stated in several ways. Most commonly, perhaps, it is stated that energy can be neither destroyed nor created, but only transformed. Another way to state this principle is that the total quantity of energy in the universe is always the same. Still another way of expressing this principle is by the equation, Energy in = Energy out,

The energy out may be quite different in form from the energy in, but the total amount of energy input must always equal the total amount of energy output.

Another principle, the **PRINCIPLE OF THE CONSERVATION OF MATTER**, states that matter can be neither created nor destroyed, but only transformed. As you probably know, the development of the atom bomb demonstrated that matter can be converted into energy; other developments have demonstrated that energy can be converted into matter. Therefore, the principle of the conservation of energy and the principle of the conservation of matter are no longer considered as two parts of a single law or principle but are combined into one principle. That principle states that matter and energy are interchangeable, and the total amount of energy and matter in the universe is constant.

The interchangeability of matter and energy is mentioned here only to point out that the statement energy in must equal energy out is not strictly true for certain situations. However, any noticeable conversion of matter into energy or energy into matter can occur only under very special conditions, which we need not consider now. All the energy transformations that we will deal with can be understood quite simply if we consider only the principle of the conservation of energy—that is, **ENERGY IN EQUALS ENERGY OUT**.

### Transformation of Heat to Work (Laws of Gases)

The energy transformation from heat to work is the major interest in the shipboard engineering plant. To see how this transformation occurs, we need to consider the pressure, temperature, and volume relationships that hold true for gases.

Robert Boyle, an English scientist, was among the first to study the compressibility of gases. In the middle of the 17th century, he called it the “springiness” of air. He discovered that when the temperature of an enclosed sample of gas was kept constant and the pressure doubled, the volume was reduced to half the former value. As the applied pressure was decreased, the resulting volume increased. From these observations he concluded that for a constant temperature, the product of the volume and pressure of an enclosed gas remains constant. This conclusion became Boyle’s law.

You can demonstrate Boyle’s law by confining a quantity of gas in a cylinder that has a tightly fitted piston. Apply force to the piston to compress the gas in the cylinder to some specific volume. If you double the force applied to the

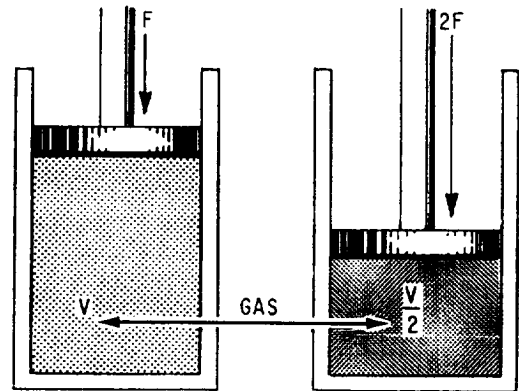

Figure 2-5.—Compressibility of gas.

piston, the gas will compress to one half its original volume (fig. 2-5).

Changes in the pressure of a gas also affect the density. As the pressure increases, its volume decreases; however, no change occurs in the weight of the gas. Therefore, the weight per unit volume (density) increases. So, the density of a gas varies directly as the pressure if the temperature is constant.

In 1787, Jacques Charles, a Frenchman, proved that all gases expand the same amount when heated 1 degree if the pressure is kept constant. The relationships that these two men discovered are summarized as follows:

- Boyle’s law—when the temperature is held constant, an increase in the pressure on a gas causes a proportional decrease in volume. A decrease in the pressure causes a proportional increase in volume, as shown in figure 2-6. At sea level, the balloon has a given volume with respect to temperature and atmospheric pressure. As the balloon descends 1 mile below sea level, the volume of the balloon decreases due to increased atmospheric pressure. Conversely, as the balloon ascends to 1 mile above sea level, the balloon expands as the atmospheric pressure decreases.

- Charles’s law—when the pressure is held constant, an increase in the temperature of a gas causes a proportional increase in volume. A decrease in the temperature causes a proportional decrease in volume, as shown in figure 2-7. Balloons A and B have an outside pressure of 10 pounds per square inch (psi). Both have the same volume of air. Balloon A is at 40°F and balloon B is at 100°F. This shows that increased temperature causes the balloon size to increase.

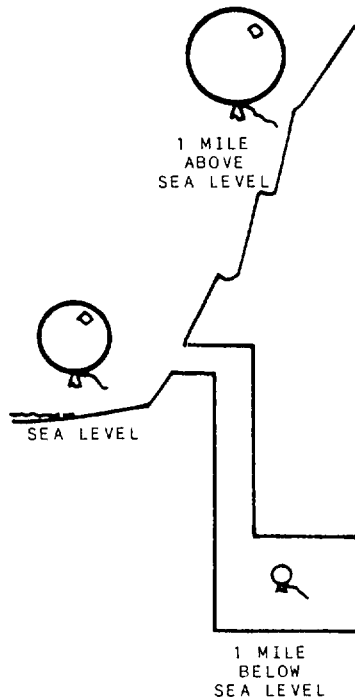

Figure 2-6.—Pressure differential in respect to sea level.

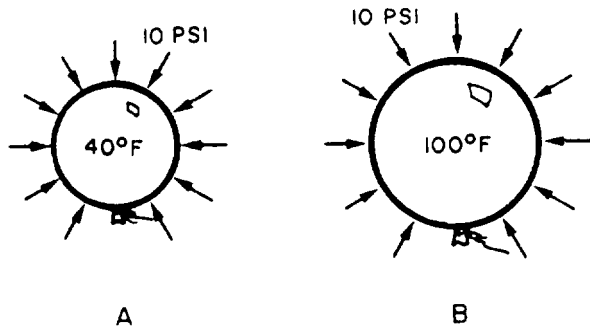

Figure 2-7.—Pressure differential in respect to temperature.

● Charles's law is also stated—when the volume is held constant, an increase in the temperature of a gas causes a proportional increase in pressure. A decrease in the temperature causes a proportional decrease in pressure, as shown in figure 2-8. Tanks A and B are of the same size and have an equal volume of gas. Tank A has a pressure of 10 psi when heated to 40°F. Tank B has a pressure of 12 psi when heated to 100°F. Unlike the balloons, the steel tanks do not expand to accommodate the changes in temperature and pressure. This shows that changes in temperature are inversely proportional to changes in gas pressure when the volume is held constant.

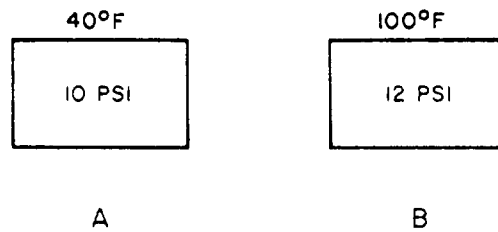

Figure 2-8.—Interaction of gases in respect to temperature and pressure.

Suppose we have a boiler in which steam has been formed. With the steam stop valves still closed, the volume of the steam remains constant while the pressure and the temperature are both increasing. When operating pressure is reached and the steam stop valves are opened, the high pressure of the steam causes the steam to flow to the turbines. The pressure of the steam thus provides the potential for doing work. The actual conversion of thermal energy to work is done in the turbine section.

### Steam

Steam is water to which enough heat has been added to convert it from the liquid to the gaseous state. When heat is added to water in an open container, steam forms. However, it quickly mixes with air and cools back to water that is dispersed in the air, making the air more humid. If you add the heat to water in a closed container, the steam builds up pressure. If you add exactly enough heat to convert all the water to steam at the temperature of boiling water, you get saturated steam. SATURATED STEAM is steam saturated with all the heat it can hold at the boiling temperature of water.

The boiling temperature of water becomes higher as the pressure over the water becomes higher. Steam hotter than the boiling temperature of water is called SUPERHEATED STEAM. When steam has 250 °F of superheat, the actual temperature is the boiling temperature plus 250 °F. At 600 psi the boiling temperature of water is 489 °F. So if steam at 600 psi has 250°F of superheat, its actual temperature is 739°F. WET STEAM is steam at the boiling temperature that still contains some water particles. DESUPERHEATED STEAM is steam that has been cooled by being passed through a pipe extending through

the steam drum. In the process, the steam loses all but 20°F to 30°F of its superheat. The advantage of desuperheated steam is that it is certain to be dry, yet not so hot as to require special alloy steels for the construction of the piping that carries the desuperheated steam about the ship.

Steam use will be discussed later in chapters 3 and 4 of this textbook. We will describe the steam cycle and typical boilers used on naval ships.

## Combustion

Combustion refers to the rapid chemical union of oxygen with fuel. Perfect combustion of fuel would result in carbon dioxide, nitrogen, water vapor, and sulphur dioxide. The oxygen required to burn the fuel is obtained from the air. Air is a mechanical mixture containing by weight 21 percent oxygen, 78 percent nitrogen, and 1 percent other gases. Only oxygen is used in combustion. Nitrogen is an inert gas that has no chemical effect upon combustion.

The chemical combination obtained during combustion results in the liberation of heat energy. A portion of this energy is used to propel the ship. Actually, what happens is a rearrangement of the atoms of the chemical elements into new combinations of molecules. In other words, when the fuel oil temperature (in the presence of oxygen) is increased to the ignition point, a chemical reaction occurs. The fuel begins to separate and unite with specific amounts of oxygen to form an entirely new substance. Heat energy is given off in the process. A good fuel burns quickly and produces a large amount of heat.

Perfect combustion is the objective. However, this has been impossible to achieve as yet in either a boiler or the cylinders of an internal-combustion engine. Theoretically, it is simple. It consists of bringing each particle of the fuel (heated to its ignition temperature) into contact with the correct amount of oxygen. The following factors are involved:

- Sufficient oxygen must be supplied.
- The oxygen and fuel particles must be thoroughly mixed.
- Temperatures must be high enough to maintain combustion.
- Enough time must be allowed to permit completion of the process.

Complete combustion can be achieved. This is accomplished by more oxygen being supplied to the process than would be required if perfect combustion were possible. The result is that some of the excess oxygen appears in the combustion gases.

## Units of Heat Measurement

Both internal energy and heat is measured using the British thermal unit (Btu). For most practical engineering purposes, 1 Btu is the thermal energy required to raise the temperature of 1 pound of pure water to 1°F. Burning a wooden kitchen match completely will produce about 1 Btu.

When large amounts of thermal energy are involved, it is usually more convenient to use multiples of the Btu. For example, 1 kBtu is equal to 1000 Btu, and 1 MBtu is equal to 1 million Btu.

Another unit in which thermal energy maybe measured is the calorie. The calorie is the amount of heat required to raise the temperature of 1 gram of pure water 1°C. One Btu equals 252 calories.

## Sensible Heat and Latent Heat

*Sensible heat* and *latent heat* are terms often used to indicate the effect that the flow of heat has on a substance. The flow of heat from one substance to another is normally reflected in a temperature change in each substance—the hotter substance becomes cooler, the cooler substance becomes hotter. However, the flow of heat is not reflected in a temperature change in a substance that is in the process of changing from one physical state (solid, liquid, or gas) to another. When the flow of heat is reflected in a temperature change, we say that sensible heat has been added to or removed from the substance (heat that can be sensed or felt). When the flow of heat is not reflected in a temperature change, but is reflected in the changing physical state of a substance, we say that latent heat has been added or removed.

Does anything bother you in this last paragraph? It should. Here we are talking about sensible heat and latent heat as though we had two different types of heat to consider. This is common (if inaccurate) engineering language. So keep the following points clearly in mind: (1) heat is the movement (flow) of thermal energy; (2) when we talk about adding and removing heat, we really mean that we are providing temperature differentials so thermal energy can flow from one substance to another; and (3) when we talk about

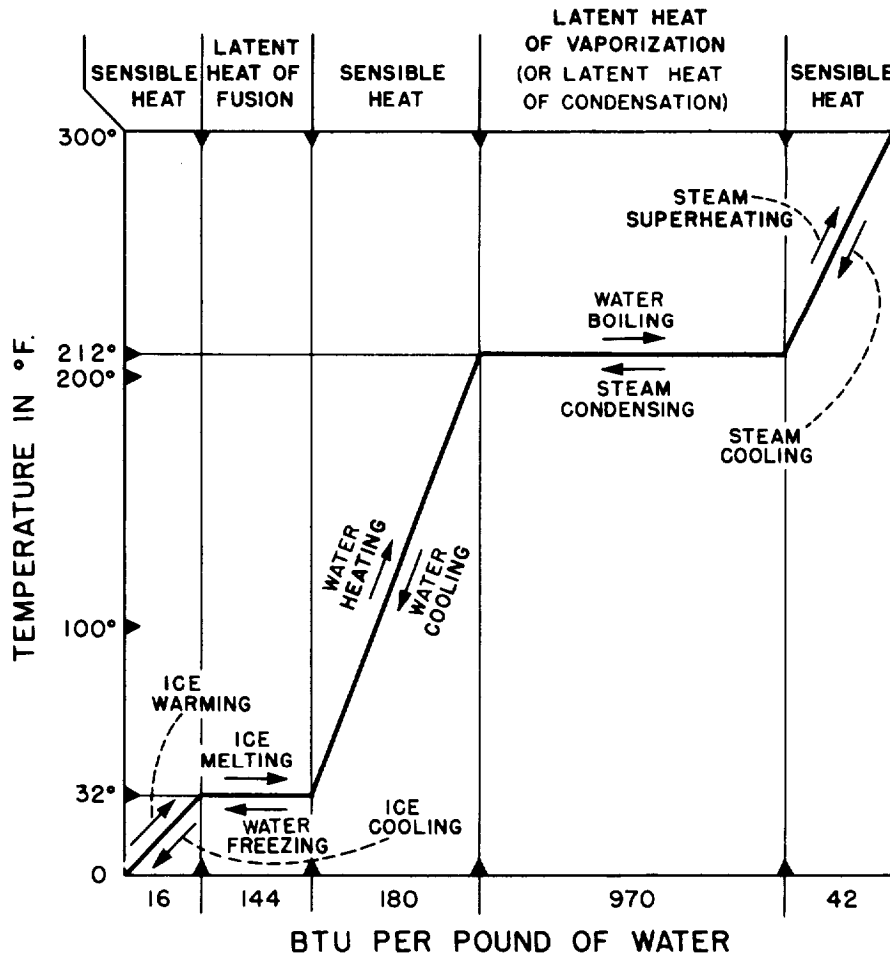

Figure 2-9.—Relationship between sensible heat and latent heat.

sensible heat and latent heat, we are talking about two different kinds of effects that can be produced by heat, but not about two different types of heat.

As previously discussed, the three basic physical states of all matter are solid, liquid, and gas (or vapor). The physical state of a substance is closely related to the distance between molecules. As a general rule, the molecules are closest together in solids, farther apart in liquids, and farthest apart in gases. When heat flow to a substance is not reflected in a temperature increase in that substance, the energy is being used to increase the distance between the molecules of the substance and to change it from a solid to a liquid or from a liquid to a gas. You might say that latent heat is the energy price that must be paid for a change of state from solid to liquid or from liquid to gas. The energy is not lost. It is stored in the substance as internal energy.

The energy price is repaid, so to speak, when the substance changes back from gas to liquid or from liquid to solid, since heat flows from the substance during these changes of state.

Figure 2-9 shows the relationship between sensible heat and latent heat for water at atmospheric pressure. The same kind of chart could be drawn for other substances; however, different amounts of thermal energy would be involved in the changes of state for each substance.

If we start with 1 pound of ice at 0°F, we must add 16 Btu to raise the temperature of the ice to 32°F. We call this adding sensible heat. To change the pound of ice at 32°F to a pound of water at 32°F, we must add 144 Btu (the LATENT HEAT OF FUSION). No change in temperature will occur while the ice is melting. After all the ice has

melted, however, the temperature of the water will be raised as additional heat is supplied. If we add 180 Btu—that is, 1 Btu for each degree of temperature between 32°F and 212°F—the temperature of the water will be raised to the boiling point. To change the pound of water at 212°F to a pound of steam at 212°F, we must add 970 Btu (the LATENT HEAT OF VAPORIZATION). After all the water has been converted to steam, the addition of more heat will cause an increase in the temperature of the steam. If we add about 44 Btu to the pound of steam that is at 212°F, we can super heat it to 300°F.

The same relationships apply when heat is being removed. The removal of 44 Btu from the pound of steam that is at 300°F will cause the temperature to drop to 212°F. As the pound of steam at 212°F changes to a pound of water at 212°F, 970 Btu are given off. When a substance is changing from a gas or vapor to a liquid, the heat that is given off is LATENT HEAT OF CONDENSATION. Notice, however, that the latent heat of condensation is exactly the same as the latent heat of vaporization. The removal of another 180 Btu of sensible heat will lower the temperature of the pound of pure water from 212°F to 32°F. As the pound of water at 32°F changes to a pound of ice at 32°F, 144 Btu are given off without any accompanying change in temperature. Further removal of heat causes the temperature of the ice to decrease.

## TEMPERATURE

The temperature of an object is a measure of the heat level of that object. This level can be measured with a thermometer.

The temperature scales employed to measure temperature are the Fahrenheit (F) scale and the Celsius (C) scale. In engineering and for practically all purposes in the Navy, the Fahrenheit scale is used. You may, however, have to convert Celsius readings to the Fahrenheit scale, so both scales are explained here.

The Fahrenheit scale has two main reference points—the boiling point of pure water at 212°F and the freezing point of pure water at 32°F. The measure of a degree of Fahrenheit is 1/180 of the total temperature change from 32°F to 212°F. The

scale can be extended in either direction—to higher temperatures without any limits and to lower temperatures (by minus degrees) down to the lowest temperature theoretically possible, absolute zero. This temperature is - 460°F, or 492°F below the freezing point of water.

In the Celsius scale, the freezing point of pure water is 0°C and the boiling point of pure water is 100°C. Therefore, 0°C and 100°C are equivalent to 32°F and 212°F, respectively. Each degree of Celsius is larger than a degree of Fahrenheit. Only 100° Celsius are between the freezing and boiling points of water, while this same temperature change requires 180° on the Fahrenheit scale. Therefore, the degree of Celsius is 180/100 or 1.8° Fahrenheit. In the Celsius scale, absolute zero is - 273°C. To convert from one temperature scale to another, use the following algebraic equations:

From Fahrenheit to Celsius

$$^{\circ}\text{C} = 5/9 \times (^{\circ}\text{F} - 32)$$

From Celsius to Fahrenheit

$$^{\circ}\text{F} = (9/5 \times ^{\circ}\text{C}) + 32$$

Figure 2-10 shows the two temperature scales in comparison. It also introduces the simplest of the temperature measuring instruments, the liquid-in-glass thermometer. The two thermometers shown are exactly alike in size and shape. The only difference is the outside markings or scales on them. Each thermometer is a hollow glass tube that is sealed at the top and has a mercury-filled bulb at the bottom. Mercury, like any liquid, expands when heated and will rise in the hollow tube. View A of figure 2-10 shows the Fahrenheit thermometer with its bulb standing in melting ice (32°F), and view B shows the Celsius thermometer with its bulb standing in boiling water (100°C).

The main point to remember is that the level of the mercury in a thermometer depends only on the temperature to which the bulb is exposed. If you were to exchange the thermometers, the mercury in the Celsius thermometer would drop to the level that the mercury now stands in the Fahrenheit thermometer. Likewise, the mercury in the Fahrenheit thermometer would rise to the level that the mercury now stands in the



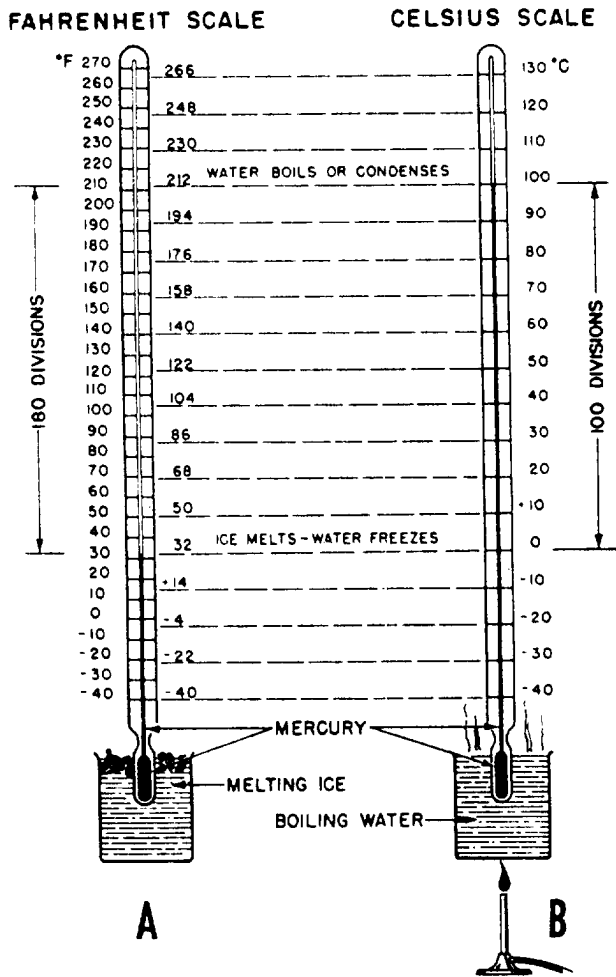

Figure 2-10.—Temperature scales. A. Fahrenheit. B. Celsius.

Celsius thermometer. The temperatures would be 0°C for the ice water and 212°F for the boiling water.

If you place both thermometers in water containing ice, the Fahrenheit thermometer will read 32°F and the Celsius thermometer will read 0°C. Heat the water slowly. The temperature will not change until the ice in the water has completely melted (a great deal of heat is required just to melt the ice). Then both mercury columns will begin to rise. When the mercury level is at the +10° mark on the Celsius thermometer, it will be at the +50° mark on the Fahrenheit thermometer. The two columns will rise together at the same speed and, when the water finally boils, they will stand at 100°C and 212°F, respectively. The same temperature change—that

is, the same amount of heat transferred to the water—has raised the temperature 100° Celsius and 180° Fahrenheit, but the actual change in heat energy is exactly the same.

### PRESSURE DEFINITIONS

Pressure, like temperature, is one of the basic engineering measurements and one that must be frequently monitored aboard ship. As with temperature readings, pressure readings provide you with an indication of the operating condition of equipment. PRESSURE is defined as the force per unit area.

The simplest pressure units are the ones that indicate how much force is applied to an area of a certain size. These units include pounds per square inch, pounds per square foot, ounces per square inch, newtons per square millimeter, and dynes per square centimeter, depending upon the system you use.

You also use another kind of pressure unit that involves length. These units include inches of water (in. H<sub>2</sub>O), inches of mercury (in.Hg), and inches of some other liquid of a known density. Actually, these units do not involve length as a fundamental dimension. Rather, length is taken as a measure of force or weight. For example, a reading of 1 in.H<sub>2</sub>O means that the exerted pressure is able to support a column of water 1 inch high, or that a column of water in a U-tube would be displaced 1 inch by the pressure being measured. Similarly, a reading of 12 in. Hg means that the measured pressure is sufficient to support a column of mercury 12 inches high. What is really being expressed (even though it is not mentioned in the pressure unit) is that a certain quantity of material (water, mercury, and so on) of known density exerts a certain definite force upon a specified area. Pressure is still force per unit area, even if the pressure unit refers to inches of some liquid.

In interpreting pressure measurements, a great deal of confusion arises because the zero point on most pressure gauges represents atmospheric pressure rather than zero absolute pressure. Thus, it is often necessary to specify the kind of pressure being measured under any given conditions. To clarify the numerous meanings of

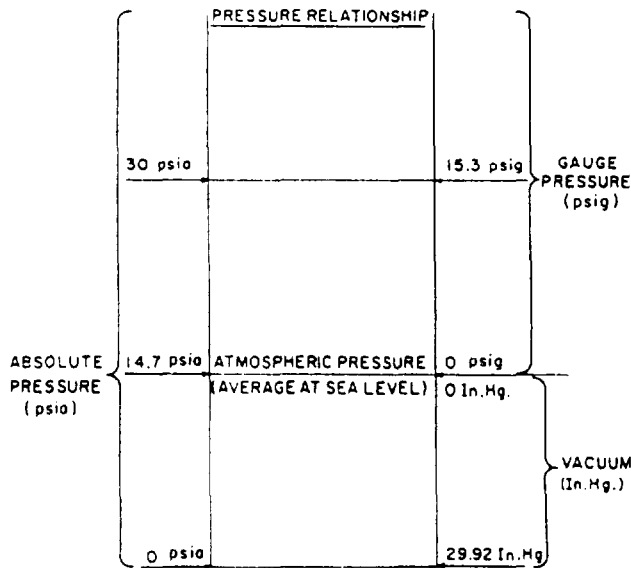

Figure 2-11.—Relationships among gauge pressure, atmospheric pressure, vacuum, and absolute pressure.

the word *pressure*, the relationships among gauge, atmospheric, vacuum, and absolute pressures are shown in figure 2-11.

**GAUGE PRESSURE** is the pressure actually shown on the dial of a gauge that registers pressure relative to atmospheric pressure. An ordinary pressure gauge reading of zero does not mean there is no pressure in the absolute sense; rather, it means there is no pressure in excess of atmospheric pressure.

**ATMOSPHERIC PRESSURE** is the pressure exerted by the weight of the atmosphere. At sea level, the average pressure of the atmosphere is sufficient to hold a column of mercury at the height of 76 centimeters or 29.92 inches. Since a column of mercury 1 inch high exerts a pressure of 0.49 pound per square inch (psi) at its base, a column of mercury 29.92 inches high exerts a pressure that is equal to  $29.92 \times 0.49$  or about 14.7 psi. Since we are dealing now in absolute pressure, we say that the average atmospheric pressure at sea level is 14.7 pounds per square inch absolute (psia). It is zero on the ordinary pressure gauge.

Notice, however, that the figure of 14.7 psia represents the average atmospheric pressure at sea level; it does not always represent the actual pressure being exerted by the atmosphere at the moment a gauge is being read. Since fluctuations from this standard are shown on a barometer (an instrument used to measure atmospheric pressure), the term *barometric pressure* is used to

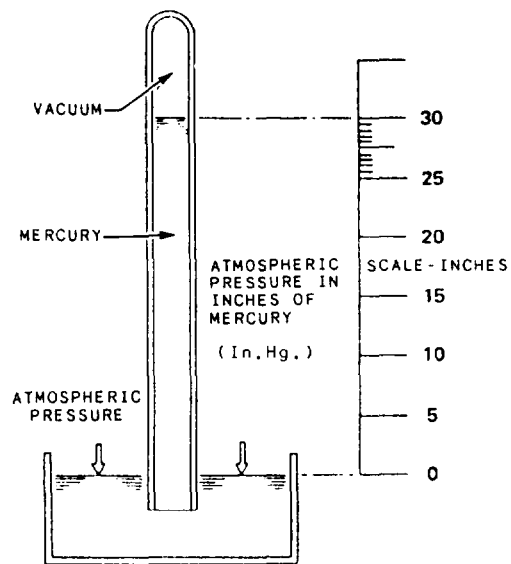

Figure 2-12.—Typical barometer.

describe the atmospheric pressure that exists at any given moment. Figure 2-12 shows the operating principle of a typical barometer.

**BAROMETRIC PRESSURE** is the term used to describe the actual atmospheric pressure that exists at any given moment. Barometric pressure may be measured by a simple mercury column or by a specially designed instrument called an aneroid barometer.

A space in which the pressure is less than atmospheric pressure is said to be under partial vacuum. The vacuum is expressed in terms of the difference between the absolute pressure in the space and the pressure of the atmosphere. Most commonly, vacuum is expressed in inches of mercury, with the vacuum gauge scale marked from 0 to 30 in.Hg. When a vacuum gauge reads zero, the pressure in the space is the same as atmospheric pressure—or, in other words, there is no vacuum. A vacuum gauge reading of 29.92 in. Hg would indicate a perfect (or nearly perfect) vacuum. In actual practice a perfect vacuum is impossible to obtain even under laboratory conditions. A reading between 0 and 29.92 in.Hg is a partial vacuum.

**ABSOLUTE PRESSURE** is atmospheric pressure plus gauge pressure, or absolute pressure minus vacuum. For example, a gauge pressure of 300 pounds per square inch gauge (psig) equals an absolute pressure of 314.7 psia ( $300 + 14.7$ ). Or, for example, consider a space in which the measured vacuum is 10 in. Hg; the absolute

pressure in this space is figured by subtracting the measured vacuum (10 in.Hg) from the nearly perfect vacuum (29.92 in.Hg). The absolute pressure then will be 19.92 or about 20 in.Hg absolute. Note that the amount of pressure in a space under vacuum can only be expressed in terms of absolute pressure.

You may have noticed that sometimes we use the letters psig to indicate gauge pressure and other times we merely use psi. By common convention, gauge pressure is always assumed when pressure is given in pounds per square inch, pounds per square foot, or similar units. The g (for gauge) is added only when there is some possibility of confusion. Absolute pressure, on the other hand, is always expressed as pounds per square inch absolute (psia), pounds per square foot absolute (psfa), and so forth. It is always necessary to establish clearly just what kind of pressure we are talking about, unless this is very clear from the nature of the discussion.

To this point, we have considered only the most basic and most common units of measurement. Remember that hundreds of other units can be derived from these units; remember also that specialized fields require specialized units of measurement. Additional units of measurement are introduced in appropriate places throughout the remainder of this training manual. When you have more complicated units of measurement, you may find it helpful to review the basic information given here first.

## PRINCIPLES OF HYDRAULICS

The word *hydraulics* is derived from the Greek word for water (*hydor*) plus the Greek word for a reed instrument like an oboe (*aulos*). The term *hydraulics* originally covered the study of the physical behavior of water at rest and in motion. However, the meaning of hydraulics has been broadened to cover the physical behavior of all liquids, including the oils that are used in modern hydraulic systems. The foundation of modern hydraulics began with the discovery of the following law and principle:

- Pascal's law—This law was discovered by Blaise Pascal, a French philosopher and mathematician who lived from 1623 to 1662 A.D. His law, simply stated, is interpreted as pressure exerted at any point upon an enclosed liquid is transmitted undiminished in all directions. Pascal's law governs the BEHAVIOR of the static

factors concerning noncompressible fluids when taken by themselves.

- Bernoulli's principle—This principle was discovered by Jacques (or Jakob) Bernoulli, a Swiss philosopher and mathematician who lived from 1654 to 1705 A.D. He worked extensively with hydraulics and the pressure-temperature relationship. Bernoulli's principle governs the RELATIONSHIP of the static and dynamic factors concerning noncompressible fluids. Figure 2-13 shows the effect of Bernoulli's principle. Chamber A is under pressure and is connected by a tube to chamber B, also under pressure. Chamber A is under static pressure of 100 psi. The pressure at some point, X, along the constricted tube consists of a velocity pressure of 10 psi. This is exerted in a direction parallel to the line of flow. Added is the unused static pressure of 90 psi, which obeys Pascal's law and operates equally in all directions. As the fluid enters chamber B from the constricted space, it slows down. In so doing, its velocity head is changed back to pressure head. The force required to absorb the fluid's inertia equals the force required to start the fluid moving originally. Therefore, the static pressure in chamber B is again equal to that in chamber A. It was lower at intermediate point X.

Figure 2-13 disregards friction, and it is not encountered in actual practice. Force or head is also required to overcome friction. But, unlike inertia effect, this force cannot be recovered again although the energy represented still exists somewhere as heat. Therefore, in an actual system the pressure in chamber B would be less than in chamber A. This is a result of the pressure used in overcoming friction along the way.

At all points in a system, the static pressure is always the original static pressure LESS any velocity head at the point in question. It is also

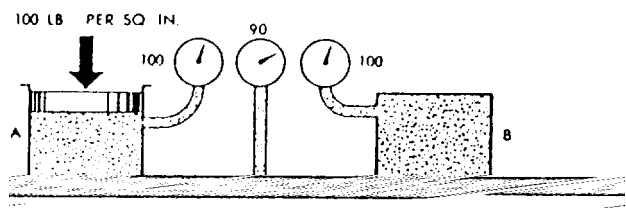

Figure 2-13.—Relationship of static and dynamic factors—Bernoulli's principle.

LESS the friction head consumed in reaching that point. Both velocity head and friction represent energy that came from the original static head. Energy cannot be destroyed. So, the sum of the static head, velocity head, and friction at any point in the system must add up to the original static head. This, then, is Bernoulli's principle; more simply stated, if a noncompressible fluid flowing through a tube reaches a constriction, or narrowing of the tube, the velocity of fluid flowing through the constriction increases, and the pressure decreases.

When we apply a force to the end of a column of confined liquid, the force is transmitted not only straight through to the other end but also equally in every direction throughout the column. This is why a flat fire hose takes on a circular cross section when it is filled with water under pressure. The outward push of the water is equal in every direction. Water will leak from the hose at the same velocity regardless of where the leaks are in the hose.

Let us now consider the effect of Pascal's law in the systems shown in figure 2-14, views A and B. If the total force at the input piston is 100 pounds and the area of the piston is 10 square inches, then each square inch of the piston surface is exerting 10 pounds of force. This liquid pressure of 10 psi is transmitted to the output piston, which will be pushed upward with a force of 10 psi. In this example, we are merely considering a liquid column of equal cross section so the areas of these pistons are equal. All we have done is to carry a 100-pound force around a bend. However, the principle shown is the basis for almost all mechanical hydraulics.

The same principle may be applied where the area of the input piston is much smaller than the area of the output piston or vice versa. In view B of figure 2-14, the area of the input piston is 2 square inches and the area of the output piston is 20 square inches. If you apply a pressure of 20 pounds to the 2 square-inch piston, the pressure created in the liquid will again be 10 psi. The upward force on the larger piston will be 200 pounds—10 pounds for each of its 20 square inches. Thus, you can see that if two pistons are used in a hydraulic system, the force acting on each piston will be directly proportional to its area.

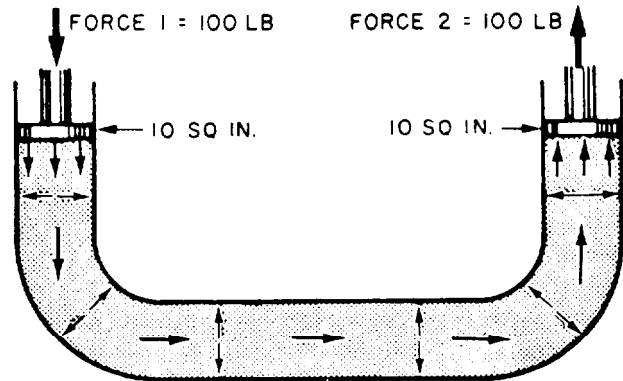

A. EQUAL INPUT AND OUTPUT AREA

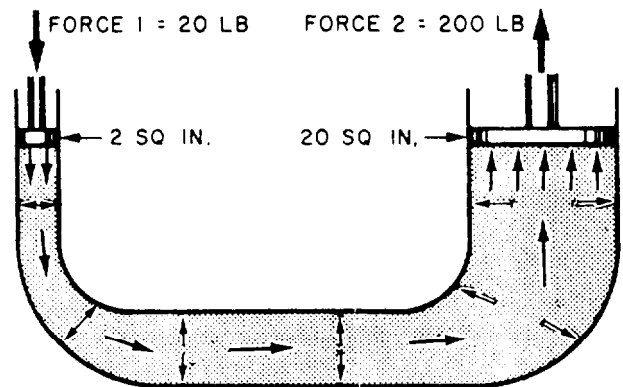

B. UNEQUAL INPUT AND OUTPUT AREA

Figure 2-14.—Principle of mechanical hydraulics. A. Equal input and output area. B. Unequal input and output area.

## PRINCIPLES OF PNEUMATICS

PNEUMATICS is that branch of mechanics that deals with the mechanical properties of gases. Perhaps the most common application of these properties in the Navy today is the use of compressed air. Compressed air is used to transmit pressure in a variety of applications. For example, in tires and air-cushioned springs, compressed air acts as a cushion to absorb shock. Air brakes on locomotives and large trucks contribute greatly to the safety of railroad and truck transportation. In the Navy, compressed air is used in many ways. For example, tools such as riveting hammers and pneumatic drills are air operated. Automatic combustion control systems

use compressed air for the operation of the instruments. Compressed air is also used in diving bells and diving suits. Our following discussion on the use of compressed air as an aid in the control of submarines will help you understand the theory of pneumatics.

Submarines are designed with a number of tanks that may be used for the control of the ship. These tanks are flooded with water to submerge, or they are filled with compressed air to surface.

The compressed air for the pneumatic system is maintained in storage tanks (called banks) at a pressure of 4500 psi. During surfacing, the pneumatic system delivers compressed air to the desired control tanks (the tanks filled with water). Since the pressure of the air is greater than the pressure of the water, the water is forced out of the tank. As a result, the weight of the ship decreases. It becomes more buoyant and rises to the surface.

## METALS

As you look around, you see not only that your ship is constructed of metal, but also that the boilers, piping system, machinery, and even your bunk and locker are constructed of some type of metal. No one type of metal can serve all the needs aboard ship. Many types of metals or metal alloys must be used. A strong metal must be used for some parts of a ship, while a lightweight metal is needed for other parts. Some areas require special metal that can be shaped or worked very easily.

The physical properties of some metals or metal alloys make them more suitable for one use than for another. Various terms are used in describing the physical properties of metals. By studying the following explanations of these terms, you should have a better understanding of why certain metals are used on one part of the ship's structure and not on another part.

**BRITTLENESS** is a property of a metal that will allow it to shatter easily. Metals, such as cast iron or cast aluminum and some very hard steels, are brittle.

**DUCTILITY** refers to the ability of a metal to stretch or bend without breaking. Soft iron, soft steel, and copper are ductile metals.

**HARDNESS** refers to the ability of a metal to resist penetration, wear, or cutting action.

**MALLEABILITY** is a property of a metal that allows it to be rolled, forged, hammered, or shaped without cracking or breaking. Copper is a very malleable metal.

**STRENGTH** refers to the ability of a metal to maintain heavy loads (or force) without breaking. Steel, for example, is strong, but lead is weak.

**TOUGHNESS** is the property of a metal that will not permit it to tear or shear (cut) easily and will allow it to stretch without breaking.

Metal preservation aboard ship is a continuous operation, since the metals are constantly exposed to fumes, water, acids, and moist salt air. All of these elements will eventually cause corrosion. The corrosion of iron and steel is called rusting. This results in the formation of iron oxide (iron and oxygen) on the surface of the metal. Iron oxide (or rust) can be identified easily by its reddish color. (A blackish hue occurs in the first stage of rusting but is seldom thought of as rust.) Corrosion can be reduced or prevented by use of better grades of alloyed metals. Chromium and nickel are commonly used. Coating the surface with paint or other metal preservatives also helps prevent rust.

Metals and alloys are divided into two general classes: ferrous and nonferrous. Ferrous metals are those composed primarily of iron. Nonferrous metals are those composed primarily of some element or elements other than iron. One way to tell a common ferrous metal from a nonferrous metal is by using a magnet. Most ferrous metal is magnetic, and nonferrous metal is nonmagnetic.

Elements must be alloyed (or mixed) together to obtain the desired physical properties of a metal. For example, alloying (or mixing) chromium and nickel with iron produces a metal known as special treatment steel (STS). An STS has great resistance to penetrating and shearing forces. A nonferrous alloy that has many uses aboard ship is copper-nickel. It is used extensively in saltwater piping systems. Copper-nickel is a mixture of copper and nickel. Many other different metals and alloys are used aboard ship that will not be discussed here.

With all the different types of metals used aboard ship, some way must be used to identify these metals in the storeroom. The Navy uses two systems to identify metals: the continuous identification marking system and the color marking system. These systems have been designed so even after a portion of the metal has been removed, the identifying marks are still visible.

In the continuous identification marking system, the identifying information is actually painted on the metal with a heavy ink. This marking appears at specified intervals over the length of the metal. The marking contains the producer's trademark and the commercial designation of the metal. The marking also indicates the physical condition of the metal, such as cold drawn, cold rolled, and seamless.

In the color marking system, a series of color symbols with a related color code is used to identify metals. The term *color symbol* refers to a color marking actually painted on the metal. The symbol is composed of one, two, or three colors and is painted on the metal in a conspicuous place. These color symbols correspond to the elements of which the metal is composed.

For further information on the metals used aboard ship, their properties and identification systems, refer to the TRAMAN, *Hull Maintenance Technician 3 & 2*, NAVEDTRA 10571-1, chapter 4.

## SUMMARY

In this chapter we have discussed some of the basic laws and principles of physics as they apply to the engineering ratings. We covered matter, magnetism, electricity, Ohm's law, Newton's laws, and mass and its different properties. Mechanical energy, thermal energy, and topics of energy transformations were described. We also provided you information on temperature, pressure definitions, principles of hydraulics, principles of pneumatics, and metals.

This chapter was provided to give you only the basis on which to expand your knowledge of electrical and mechanical fundamentals. It is important that you have a sound understanding of these laws and principles. The complex electrical and mechanical systems and the internal pressure-temperature relationships in an engineering plant make it imperative that you understand the material presented. If you have problems understanding this material, you should reread the pertinent portions until you have absorbed the basic concepts. You will use this information throughout your naval career. Study this information so you will have a good foundation of understanding within the engineering department of your ship.

## CHAPTER 3

# BASIC STEAM CYCLE

To understand steam generation, you must know what happens to the steam after it leaves the boiler. A good way to learn the steam plant on your ship is to trace the path of steam and water throughout its entire cycle of operation. In each cycle, the water and the steam flow through the entire system without ever being exposed to the atmosphere. The four areas of operation in a main steam system are generation, expansion, condensation, and feed. After studying this chapter, you will have the knowledge and ability to describe the main steam cycle and the functions of the auxiliary steam systems.

### MAIN STEAM SYSTEM

The movement of a ship through the water is the result of a number of energy transformations. Although these transformations were mentioned in the last chapter, we will now discuss these transformations as they occur. Figure 3-1 shows the four major areas of operation in the basic steam cycle and the major energy transformations that take place. These areas are A—generation, B—expansion, C—condensation, and D—feed.

**GENERATION**—The first energy transformation occurs in the boiler furnace when fuel oil burns. By the process of combustion, the chemical energy stored in the fuel oil is transformed into thermal energy. Thermal energy flows from the burning fuel to the water and generates steam. The thermal energy is now stored as internal energy in steam, as we can tell from the increased pressure and temperature of the steam.

**EXPANSION**—When steam enters the turbines and expands, the thermal energy of the steam converts to mechanical energy, which turns the shaft and drives the ship.

For the remainder of the cycle, energy is returned to the water (**CONDENSATION** and **FEED**) and back to the boiler where it is again heated and changed into steam. The energy used for this purpose is the thermal energy of the auxiliary steam.

The following paragraphs will explain the four major areas of operation in the basic steam cycle shown in figure 3-1.

### GENERATION

When a liquid boils, it generates a vapor. Some or all of the liquid changes its physical state from liquid to gas (or vapor). As long as the vapor is in contact with the liquid from which it is being generated, it remains at the same temperature as the boiling liquid. In this condition, the liquid and its vapors are in equilibrium contact with each other. Area A of figure 3-1 shows the **GENERATION** area of the basic steam cycle.

The temperature at which a boiling liquid and its vapors may exist in equilibrium contact depends on the pressure under which the process takes place. As the pressure increases, the boiling temperature increases. As the pressure decreases, the boiling temperature decreases. Determining the boiling point depends on the pressure.

When a liquid is boiling and generating vapor, the liquid is a **SATURATED LIQUID** and the vapor is a **SATURATED VAPOR**. The temperature at which a liquid boils under a given pressure is the **SATURATION TEMPERATURE**, and the corresponding pressure is the **SATURATION PRESSURE**. Each pressure has a corresponding saturation temperature, and each temperature has a corresponding saturation

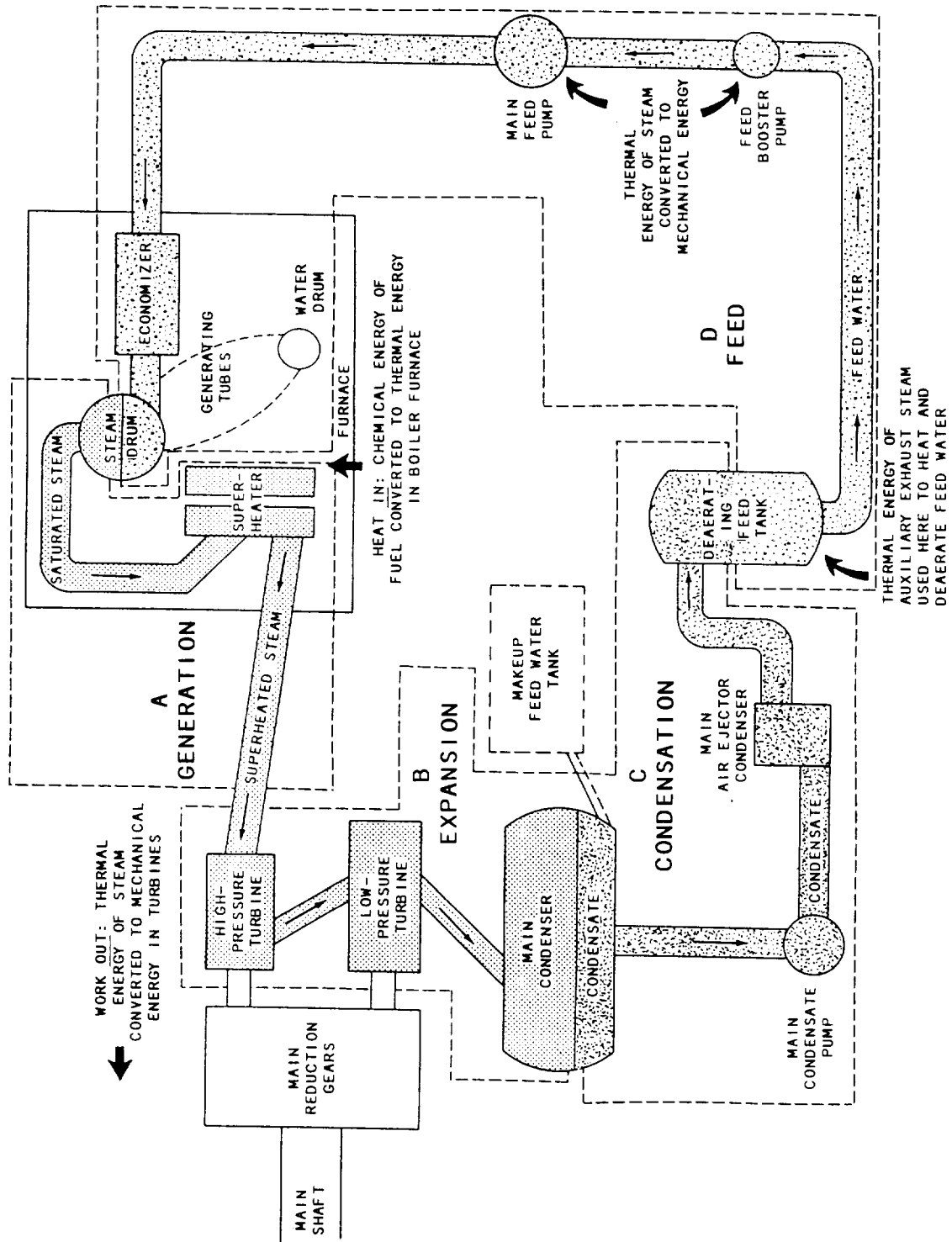

Figure 3-1.—Basic steam cycle.



pressure. A few saturation pressures and temperatures for water are as follows:

Pounds Per Square Inch Absolute (psia)	Degrees Fahrenheit (°F)
11 . . . . .	198
14.7 . . . . .	212
110 . . . . .	335
340 . . . . .	429
630 . . . . .	567
1200 . . . . .	596
2000 . . . . .	636
3000 . . . . .	695
3206.2 . . . . .	705.40

We know that atmospheric pressure is 14.7 psia at sea level and lesser at higher altitudes. Boiling water on top of a mountain takes a lot longer than at sea level. Why is this? As noted before, temperature and pressure are indications of internal energy. Since we cannot raise the temperature of boiling water above the saturation temperature for that pressure, the internal energy available for boiling water is less at higher altitudes than at sea level. By the same lines of reasoning, you should be able to figure out why water boils faster in a pressure cooker than in an open kettle.

A peculiar thing happens to water and steam at an absolute pressure of 3206.2 psia and the corresponding saturation temperature at 705.40°F. At this point, the CRITICAL POINT, the vapor and liquid are indistinguishable. No change of state occurs when pressure increases above this point or when heat is added. At the critical point, we no longer refer to water or steam. At this point we cannot tell the waterer steam apart. Instead, we call the substance a fluid or a working substance. Boilers designed to operate at pressures and temperatures above the critical point are SUPERCRITICAL boilers. Supercritical boilers are not used, at present, in propulsion plants of naval ships; however, some boilers of this type are used in stationary steam power plants.

If we generate steam by boiling water in an open pan at atmospheric pressure, the water and steam that is in immediate contact with the water

will remain at 212°F until all the water evaporates. If we fit an absolutely tight cover to the pan so no steam can escape while we continue to add heat, both the pressure and temperature inside the vessel will rise. The steam and water will both increase in temperature and pressure, and each fluid will be at the same temperature and pressure as the other.

In operation, a boiler is neither an open vessel nor a closed vessel. It is a vessel designed with restricted openings allowing steam to escape at a uniform rate while feedwater is brought in at a uniform rate. Steam generation takes place in the boiler at constant pressure and constant temperature, less fluctuations. Fluctuations in constant pressure and constant temperature are caused by changes in steam demands.

We cannot raise the temperature of the steam in the steam drum above the temperature of the water from which it is being generated until the steam is removed from contact with the water inside the steam drum and then heated. Steam that has been heated above its saturation temperature at a given pressure is SUPERHEATED STEAM. The vessel in which the saturated steam is superheated is a SUPERHEATER.

The amount by which the temperature of superheated steam exceeds the temperature of saturated steam at the same pressure is the DEGREE OF SUPERHEAT. For example, if saturated steam at 620 psia with a corresponding saturation temperature of 490°F is superheated to 790°F, the degree of superheat is 300°F (790 – 490 = 300).

Most naval propulsion boilers have superheaters. The primary advantage is that superheating steam provides a greater temperature differential between the boiler and the condenser. This allows more heat to be converted to work at the turbines. We will discuss propulsion boilers and component parts more extensively in the next chapter. Another advantage is that superheated steam is dry and therefore causes relatively little corrosion or erosion of machinery and piping. Also, superheated steam does not conduct or lose heat as rapidly as saturated steam. The increased efficiency which results from the use of superheated steam reduces the fuel oil required to generate each pound of steam. It also reduces the space and weight requirements for the boilers.

Most auxiliary machinery operates on saturated steam. Reciprocating machinery, in particular, requires saturated steam to lubricate internal moving parts of the steam end. Naval boilers, therefore, produce both saturated steam and superheated steam.

## EXPANSION

The EXPANSION area of the main steam system is that part of the basic steam cycle in which steam from the boilers to the main turbines is expanded. This removes the heat energy stored in the steam and transforms that energy into mechanical energy of rotation.

The main turbines usually have a high-pressure (HP) turbine and a low-pressure (LP) turbine. The steam flows into the HP turbine and on into the LP turbine. Area B of figure 3-1 shows the expansion area of the main steam system. This portion of the main steam system contains HP and LP turbines.

## CONDENSATION

Each ship must produce enough feedwater for the boilers and still maintain an efficient engineering plant. Therefore, feedwater is used over and over again.

As the steam leaves or exhausts from the LP turbine, it enters the CONDENSATE system. The condensate system is that part of the steam cycle in which the steam is condensed back to water. Then it flows from the main condenser toward the boilers while it is being prepared for use as feedwater.

The components of the condensate system are (1) the main condenser, (2) the main condensate pump, (3) the main air ejector condenser, and (4) the top half of the deaerating feed tank (DFT). These components are shown in area C of figure 3-1.

The main condenser receives steam from the LP turbine. It condenses the steam into water. We will explain this process in the next chapter on boilers. The main condensate pump takes suction from the main condenser hot well. It delivers the condensate into the condensate piping system and through the main air ejector condenser. As its name implies, the air ejector removes air and noncondensable gases from the main condenser that leak or are discharged into it during normal operation. The condensate is used as a cooling medium for condensing the steam in the inter and after condensers of the main air ejector.

## FEED

The DFT (fig. 3-2) is the dividing line between condensate and feedwater. The condensate enters the DFT through the spray nozzles and turns into feedwater in the reservoir section of the DFT. The DFT has three basic functions:

- To remove dissolved oxygen and non-condensable gases from the condensate
- To preheat the water
- To act as a reservoir to store feedwater to take care of fluctuations in feedwater demand or condensate supply

The condensate enters the DFT through the condensate inlet. There it is sprayed into the dome of the tank by nozzles. It is discharged in a fine spray throughout the steam-filled top. The fine spray and heating of the condensate releases trapped air and oxygen. The gas-free condensate falls to the bottom of the tank through the water collecting cones, while the air and oxygen are exhausted from the tank vent.

The collected condensate in the storage section of the DFT is now called feedwater and becomes a source of supply for the main feed booster pump. The main feed booster pump takes suction from the DFT and maintains a constant discharge pressure to the main feed pump.

The main feed pump receives the water (delivered from the booster pump) and discharges it into the main feed piping system. Area D of figure 3-1 shows the path of the water from the DFT to the economizer. The discharge pressure of the main feed pump is maintained at 100 to 150 psig above boiler operating pressure on 600-psi plants. On 1200-psi plants, it is maintained at 200 to 300 psig above boiler operating pressure. The discharge pressure is maintained throughout the main feed piping system. However, the quantity of water discharged to the economizer is controlled by a feed stop and check valve or automatic feedwater regulator valve.

The economizer is positioned on the boiler to perform one basic function. It acts as a preheater. The gases of combustion flow around the economizer tubes and metal projections that extend from the outer tube surfaces. The tubes and projections absorb some of the heat of combustion and heat the water that is flowing through the economizer tubes. As a result, the water is about 100 °F hotter as it flows out of the economizer to the boiler.

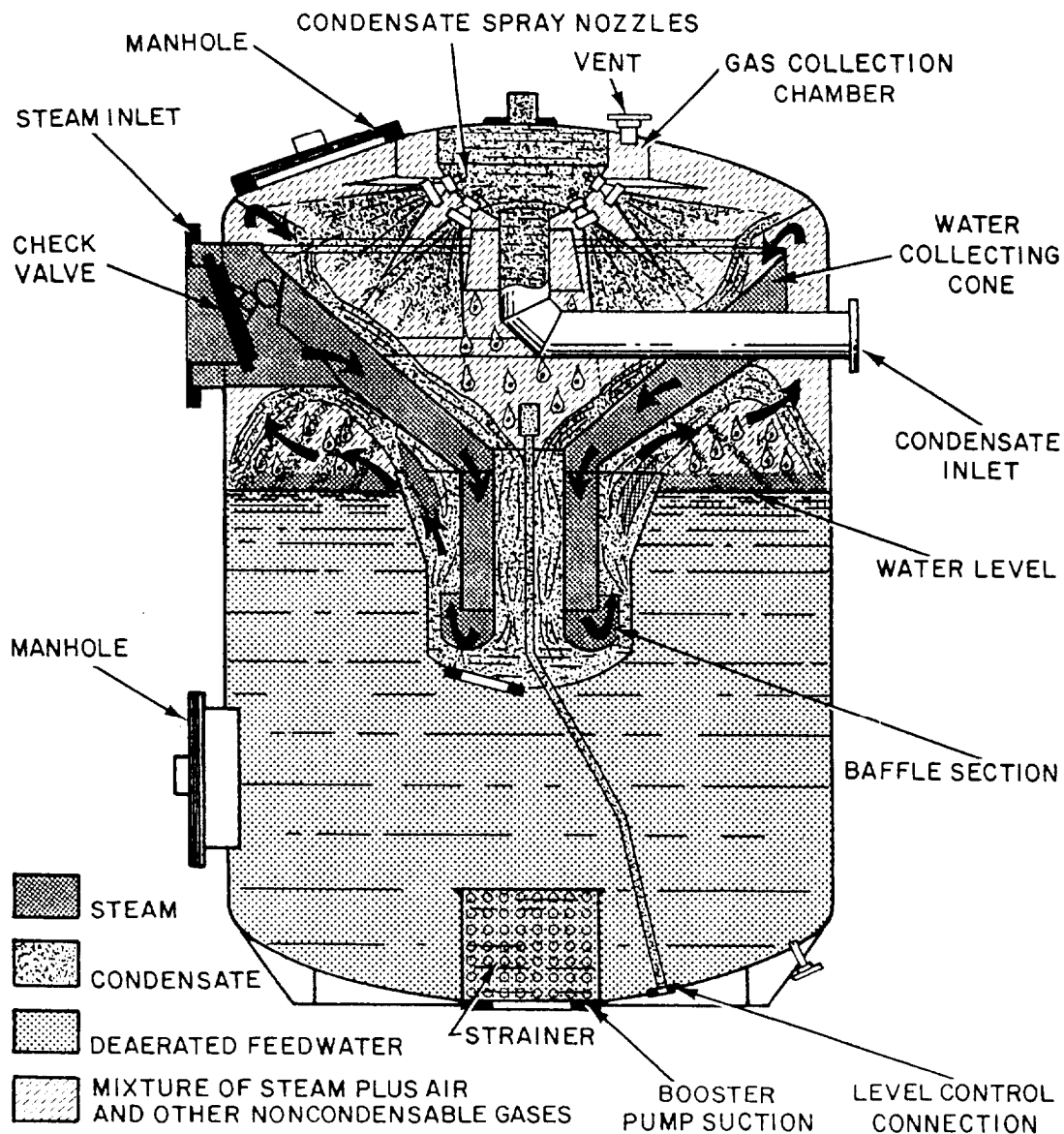

38.17

Figure 3-2.—Deaerating feed tank.

### AUXILIARY STEAM SYSTEM

Auxiliary steam systems supply steam at the pressures and temperatures required cooperate many systems and machinery, both inside and outside engineering spaces. As discussed previously, auxiliary steam is often called saturated steam or desuperheated steam.

Many steam systems and machinery receive their steam supply from auxiliary steam systems on most steam-driven ships. Some typical examples

are constant and intermittent service steam systems, steam smothering systems, ships' whistles, air ejectors, forced draft blowers, and a wide variety of pumps. Some newer ships use main steam instead of auxiliary steam for the forced draft blowers and for some pumps. Aboard some ships, turbine gland sealing systems receive their steam supply from an auxiliary steam system. Other ships may receive their supply from the auxiliary exhaust system. Gland sealing steam is supplied to the shaft glands of propulsion and

generator turbines to seal the shaft glands against leakage. This leakage includes air leaking into the turbine casings and steam leaking out of the turbine casings. More use of electrically driven (rather than turbine-driven) auxiliaries has simplified auxiliary steam systems on newer ships.

### **SUMMARY**

In this chapter, you have learned about the main steam system, the auxiliary steam system,

and the use of steam after it leaves the boiler. Remember, steam and feedwater are recycled over and over again to provide heat and power to operate machinery. It is important that you understand the terminology associated with steam and feedwater systems. You will use these terms in your day-to-day routine aboard ship. Some of the subjects will be discussed in greater detail in later chapters. All of these areas are important in their own right. As you learn this information, you will become a more proficient and reliable technician.

## CHAPTER 4

# BOILERS

The function of a boiler in the steam cycle is to convert water into steam. Reliability in operating naval boilers and associated equipment is important for the power plant to operate at maximum efficiency. The complex design of naval boilers requires a high degree of technical knowledge and skill on the part of the fireroom personnel responsible for boiler operations. All engineers should have some knowledge of the principles of combustion, how combustion occurs in a boiler, and the combustion requirements for operating a boiler more efficiently. You may want to review combustion in chapters 2 and 3 of this textbook.

This chapter describes boilers commonly used in propulsion plants of naval steam-driven surface ships. This information is general in nature and does not relate to any one class of ship. Chapter 221 of the *Naval Ships' Technical Manual* is the basic doctrine reference on boilers. For detailed information on the boilers in any particular ship, consult the manufacturer's technical manuals furnished with the boilers.

Upon completion of this chapter, you will have the knowledge to be able to identify and understand boiler terminology, the basic types of naval boilers and their operating principles, interpret gauges and indicators that aid in monitoring operating parameters of naval boilers, and understand boiler construction. You should be able to identify the major parts of a boiler and its functions. Also, you will learn about safety precautions that must be observed during boiler light-off.

### BOILER TERMINOLOGY

Before studying the types of boilers used in propulsion plants aboard Navy ships, you need to know the boiler terms and definitions used most frequently by shipboard personnel. In this section we have listed some of the terms used in this

chapter and by fireroom personnel on the job. It is not an all-inclusive list, but it will help form a basis for your understanding of the information presented on boilers.

- **Fireroom**— The fireroom is a compartment containing boilers and the operating station for firing the boilers.
- **Boiler room**— The boiler room is a compartment containing boilers but not containing the station for firing or operating the boiler.
- **Main machinery room**— The main machinery room is a compartment containing boilers and the station for firing or operating the boilers and main propulsion engines.
- **Boiler operating station**— The boiler operating station is a station from which a boiler or boilers are operated, applying particularly to the compartment from which the boilers are operated.
- **Steaming hours**— Steaming hours is the time during which the boilers have fires lighted until fires are secured.
- **Boiler full-power capacity**— Boiler full-power capacity is specified in the contract specifications of a ship. It is expressed as the number of pounds of steam generated per hour at the pressure and temperature required for all purposes to develop contract shaft hp of the ship divided by the number of boilers installed. Boiler full-power capacity is listed in the design data section of the manufacturer's technical manual for the boilers in each ship. It may be listed either as the capacity at full power or as the designed rate of actual evaporation per boiler at full power.

- **Boiler overload capacity**— Boiler overload capacity is specified in the design of the boiler. It is usually 120 percent of boiler full-power capacity, for either steaming rate or firing rate, as specified for the individual installation.
- **Superheater outlet pressure**— Superheater outlet pressure is the actual pressure at the superheater outlet at any given time.
- **Steam drum pressure**— Steam drum pressure is the actual pressure carried in the boiler steam drum at any given time.
- **Operating pressure**— Operating pressure is the constant pressure at which the boiler is being operated. This pressure may be carried at either the steam drum or the superheater outlet, depending on the design feature of the boiler. Operating pressure is specified in the manufacturer's technical manual.
- **Design pressure**— Design pressure is the maximum pressure specified by the boiler manufacturer as a criterion for boiler design. Design pressure is not the same as operating pressure. It is somewhat higher than operating pressure. Design pressure is given in the manufacturer's technical manual for the particular boiler.
- **Design temperature**— Design temperature is the maximum operating temperature at the superheater outlet at some specified rate of operation. For combatant ships the specified rate of operation is normally full-power capacity.
- **Operating temperature**— Operating temperature is the actual temperature at the superheater outlet. Operating temperature is the same as design temperature ONLY when the boiler is operating at rate specified in the definition of design temperature.
- **Boiler efficiency**— The efficiency of a boiler is the Btu's per pound of fuel absorbed by the water and steam divided by the Btu's per pound of fuel fired. In other words, boiler efficiency is output divided by input, or heat used divided by heat available. Boiler efficiency is expressed as a percent.
- **Superheater surface**— The superheater surface is that portion of the total heating surface where the steam is heated after leaving the boiler steam drum.
- **Economizer surface**— The economizer surface is that portion of the total heating surface where the feed water is heated before it enters the boiler steam drum.
- **Total heating surface**— The total heating surface area is the area of the generating, economizer, and superheater tube banks exposed in the boiler furnace. These tubes are that part of the heat transfer that exposes one side to combustion gases and the other side to the water or steam being heated.

## BOILER CLASSIFICATION

Boilers vary considerably in detail and design. Most boilers may be classified and described in terms of a few basic features or characteristics. Some knowledge of the methods of classification provides a useful basis for understanding the design and construction of the various types of naval boilers.

In the following paragraphs, we have considered the classification of naval boilers according to intended service, location of fire and water spaces, type of circulation, arrangement of steam and water spaces, number of furnaces, burner location, furnace pressure, type of superheaters, control of superheat, and operating pressure.

## INTENDED SERVICE

A good place to begin in classifying boilers is to consider their intended service. By this method of classification, naval boilers are divided into two classes, PROPULSION BOILERS and AUXILIARY BOILERS. Propulsion boilers are used to provide steam for ships' propulsion and for vital auxiliaries' services. Auxiliary boilers are installed in diesel-driven ships and in many steam-driven combatant ships. They supply the steam and hot water for galley, heating, and other hotel services and for other auxiliary requirements in port.

## **LOCATION OF FIRE AND WATER SPACES**

One of the basic classifications of boilers is according to the relative location of the fire and water spaces. By this method of classification, boilers are divided into two classes, FIRE-TUBE BOILERS and WATER-TUBE BOILERS. In the fire-tube boilers, the gases of combustion flow through the tubes and thereby heat the water that surrounds the tubes. In water-tube boilers, the water flows through the tubes and is heated by the gases of combustion that fill the furnace and heat the outside metal surfaces of the tubes.

All propulsion boilers used in naval ships are of the water-tube type. Auxiliary boilers may be either fire-tube or water-tube boilers.

## **TYPE OF CIRCULATION**

Water-tube boilers are further classified according to the method of water circulation. Water-tube boilers may be classified as NATURAL CIRCULATION BOILERS or FORCED CIRCULATION BOILERS.

In natural circulation boilers, the circulation of water depends on the difference between the density of an ascending mixture of hot water and steam and a descending body of relatively cool and steam-free water. The difference in density occurs because the water expands as it is heated, and thus, becomes less dense. Another way to describe natural circulation is to say that it is caused by convection currents which result from the uneven heating of the water contained in the boiler.

Natural circulation may be either free or accelerated. In a boiler with free natural circulation, the generating tubes are installed almost horizontally, with only a slight incline toward the vertical. When the generating tubes are installed at a much greater angle of inclination, the rate of water circulation is definitely increased. Therefore, boilers in which the tubes slope quite steeply from steam drum to water drum are said to have natural circulation of the accelerated type.

Most naval boilers are designed for accelerated natural circulation. In such boilers, large tubes (3 inches or more in diameter) are installed between the steam drum and the water drum. These large tubes, or DOWNCOMERS, are located outside the furnace and away from the heat of combustion. They serve as pathways for the downward flow of relatively cool water. When

enough downcomers are installed, all small tubes can be generating tubes, carrying steam and water upward, and all downward flow can be carried by downcomers. The size and number of downcomers installed varies from one type of boiler to another, but downcomers are installed in all naval boilers.

Forced circulation boilers are, as their name implies, quite different in design from the boilers that use natural circulation. Forced circulation boilers depend upon pumps, rather than upon natural differences in density, for the circulation of water within the boiler. Because forced circulation boilers are not limited by the requirements that hot water and steam must be allowed to flow upward while the cooler water flows downward, a great variety of arrangements may be found in forced circulation boilers.

## **ARRANGEMENT OF STEAM AND WATER SPACES**

Natural circulation water-tube boilers are classified as DRUM-TYPE BOILERS or HEADER-TYPE BOILERS, depending on the arrangement of the steam and water spaces. Drum-type boilers have one or more water drums (and usually one or more water headers as well). Header-type boilers have no water drum; instead, the tubes enter many headers which serve the same purpose as water drums.

What is a header, and what is the difference between a header and a drum? The term *header* is commonly used in engineering to describe any tube, chamber, drum, or similar piece to which tubes or pipes are connected in such a way as to permit the flow of fluid from one tube (or group of tubes) to another. Essentially, a header is a type of manifold or collection point. As far as boilers are concerned, the only distinction between a drum and a header is size. Drums may be entered by a person while headers cannot. Both serve basically the same purpose.

Drum-type boilers are further classified according to the overall shape formed by the steam and water spaces—that is, by the tubes. For example, double-furnace boilers are often called M-type boilers because the arrangement of the tubes is roughly M-shaped. Single-furnace boilers are often called D-type boilers because the tubes form a shape that looks like the letter *D*.

## NUMBER OF FURNACES

All boilers commonly used in the propulsion plants of naval ships may be classified as either SINGLE-FURNACE BOILERS or DOUBLE-FURNACE BOILERS. The D-type boiler is a single-furnace boiler; the M-type boiler is a double-furnace (divided-furnace) boiler.

## BURNER LOCATION

Naval boilers are also classified on the basis of where their burners are located. Most burners in naval propulsion plants are located at the front of the boiler. These are called FRONT-FIRED BOILERS. Other ships, such as the AO-177 and LKA-113 class ships, have their burners on the top of the boilers. These are called TOP-FIRED BOILERS.

## FURNACE PRESSURE

Another convenient boiler classification is based on the air pressure used in the furnace. Most boilers in use in naval propulsion plants operate with a slight air pressure (seldom over 5 psig) in the boiler furnace. This slight pressure is not enough to justify calling these boilers pressurized-furnace boilers. However, some boilers installed on naval ships are truly pressurized-furnace boilers. They are called PRESSURE-FIRED or SUPERCHARGED BOILERS. These furnaces are maintained under a positive air pressure of about 65 psia (about 50 psig) when operated at full power. The air pressure in these boiler furnaces is maintained by special air compressors called superchargers.

## TYPE OF SUPERHEATERS

On almost all boilers used in the propulsion plants of naval ships, the superheater tubes are protected from radiant heat by water screen tubes. The water screen tubes absorb the intense radiant heat of the furnace, and the superheater tubes are heated by convection currents rather than by direct radiation. These superheaters are called CONVECTION-TYPE SUPERHEATERS.

In a few older ships, the superheater tubes are not screened by water screen tubes but are exposed directly to the radiant heat of the furnace. Superheaters of this design are called RADIANT-TYPE SUPERHEATERS.

## CONTROL OF SUPERHEAT

A boiler that provides some means of controlling the degree of superheat independently of the rate of steam generation is said to have CONTROLLED SUPERHEAT. A boiler in which such separate control is not possible is said to have UNCONTROLLED SUPERHEAT.

Normally, the term *superheat control boiler* is used to identify a double-furnace boiler. The term *uncontrolled superheat boiler* is used to identify a single-furnace boiler.

## OPERATING PRESSURE

For some purposes, it is convenient to classify boilers according to operating pressure. Most classification of this type are approximate rather than exact. Header-type boilers and some older drum-type boilers are often called 400-PSI BOILERS even though their operating pressures range from about 435 psi to 700 psi.

The term *high-pressure boiler* is at present used rather loosely to identify any boiler that operates at a substantially higher pressure than the so-called 600-PSI BOILERS. In general, we will consider any boiler that operates at 751 psi or above as a high-pressure boiler. Many boilers in naval ships operate at about 1200 psi. These boilers are referred to as 1200-PSI BOILERS.

As you can see, classifying boilers by operating pressure is not very precise since actual operating pressure may vary widely within any one group. Also, any classification based on operating pressure may easily become obsolete. What is called a high-pressure boiler today may well be called a low-pressure boiler tomorrow.

## BOILER COMPONENTS

Boilers used onboard naval ships have essentially the same components: steam and water drums, generating and circulating tubes, superheaters, economizers, and accessories and fittings for controlling steam pressure and temperature and other aspects of boiler control and operation.

Figure 4-1 shows a cutaway view of a D-type boiler. You should refer to this figure as a guide to the arrangement of the boiler components. As we discuss the boiler and its components, imagine that you are assembling a similar boiler. As you



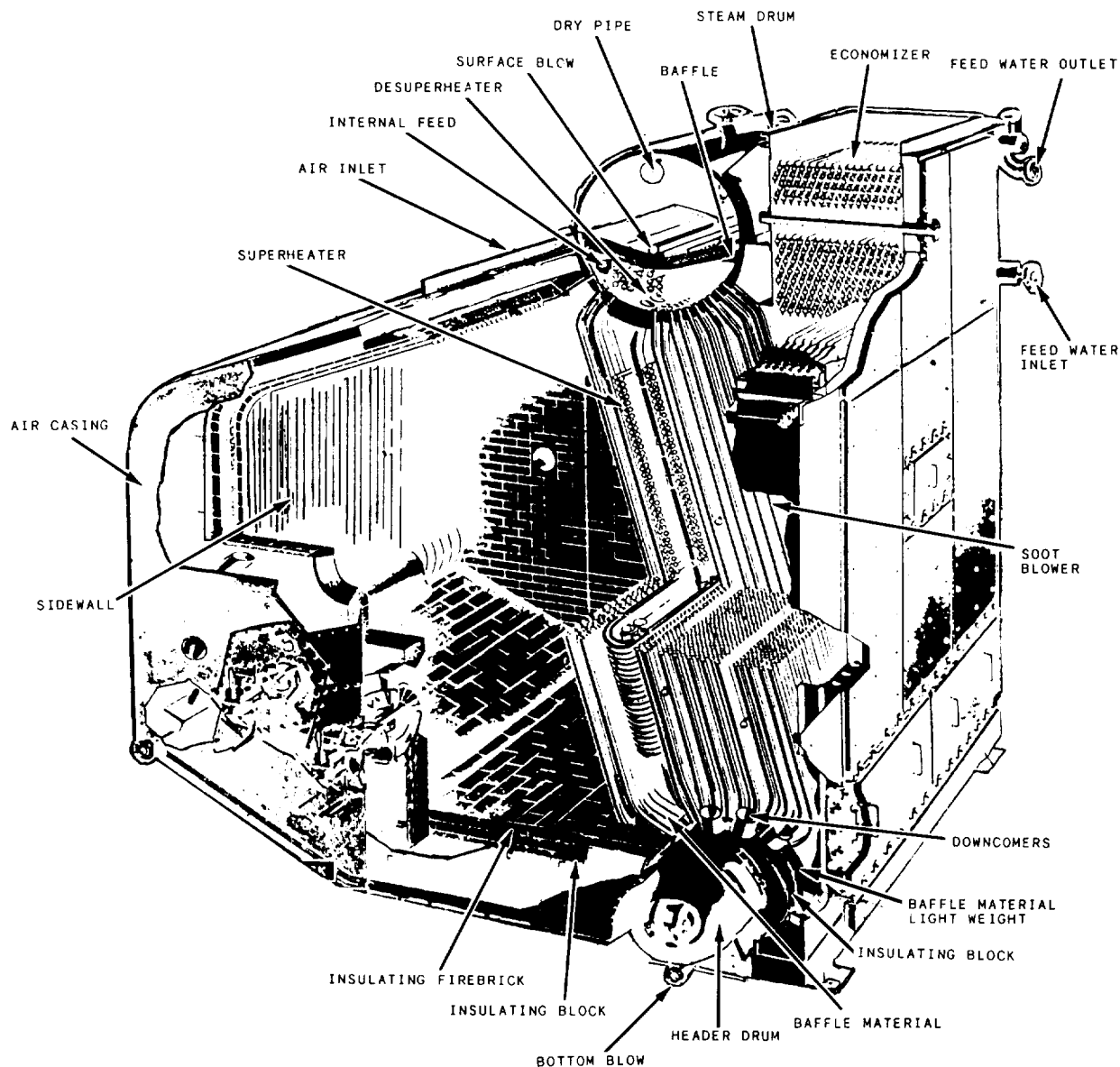

Figure 4-1.—Cutaway view of a D-type boiler.

add each part to your boiler, follow the line drawings introduced in the following paragraphs that describe the position of each component.

### STEAM DRUM

The steam drum is a cylinder located at the top of the boiler. It runs lengthwise (fig. 4-1) from the front to the back of the boiler. The steam drum provides a space for the saturated steam generated in the tubes and for the separation of moisture from the steam. (Remember, saturated

steam is steam that has not been heated above the temperature of the water from which it was generated). The steam drum also serves as a storage space for boiler water, which is distributed from the steam drum to the downcomer tubes. During normal operation, the steam drum is kept about half full of water. The steam drum either contains or is connected to many of the important controls and fittings required for the operation of the boiler.

At the bottom right side of the boiler you will find the water drum, and on the bottom left side

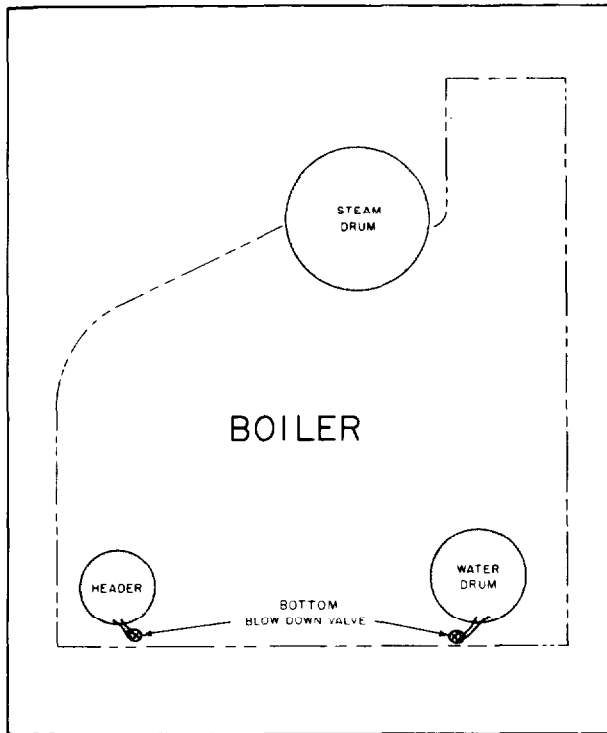

Figure 4-2.—Steam drum, water drum, and header.

is the sidewall header (fig. 4-2). Notice the header is smaller than the water drum. Most boilers have more than one header. They are identified by their location. For example, a header at the back of the boiler is called a rear wall header. A header on a screen wall is called a screen wall header.

### WATER DRUM

The water drum is larger than the header, but both are smaller than the steam drum. The water drum equalizes the distribution of water to the generating tubes. Both the water drum and the header collect the deposits of loose scale and other solid matter present in the boiler water. Both the drum and the header have bottom blowdown valves. When these valves are opened, some of the water is forced out of the drum or header and carries any loose particles with it. **DO NOT OPEN THE BOTTOM BLOWDOWN VALVES ON A STEAMING BOILER.** Opening these valves will interrupt the circulation of the steam cycle.

### DOWNCOMER TUBES

At each end of the steam drum are a number of large tubes (fig. 4-3) that lead to the water drum

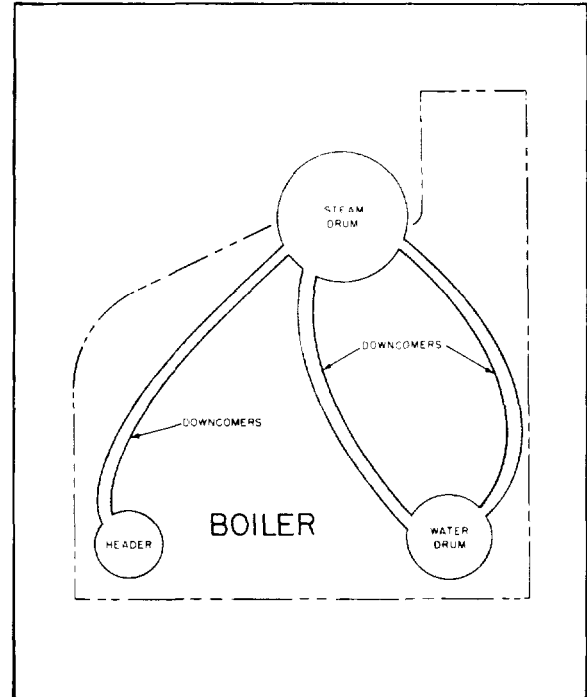

Figure 4-3.—Downcomer tubes.

and sidewall header. These tubes are the downcomers through which water flows downward from the steam drum to the water drum and the header. The downcomers range in diameter from 3 to 8 inches.

### GENERATING TUBES

Many tubes link the steam drum to the water drum and to the header. The tubes that lead from the water drum to the steam drum are the generating tubes (fig. 4-4). They are arranged in the furnace so the gases and the heat of combustion can flow around them. The large arrows in figure 4-4 show the direction of flow of the combustion gases.

The generating tubes are made of steel that is strong enough to withstand the high pressures and temperatures within the boiler. In most boilers these tubes are usually 1 to 2 inches in diameter, but some may be 3 inches. These small tubes present a large surface area to absorb furnace heat. A 2-inch tube has twice the surface area of a 1-inch tube but four times the volume. A 3-inch tube has three

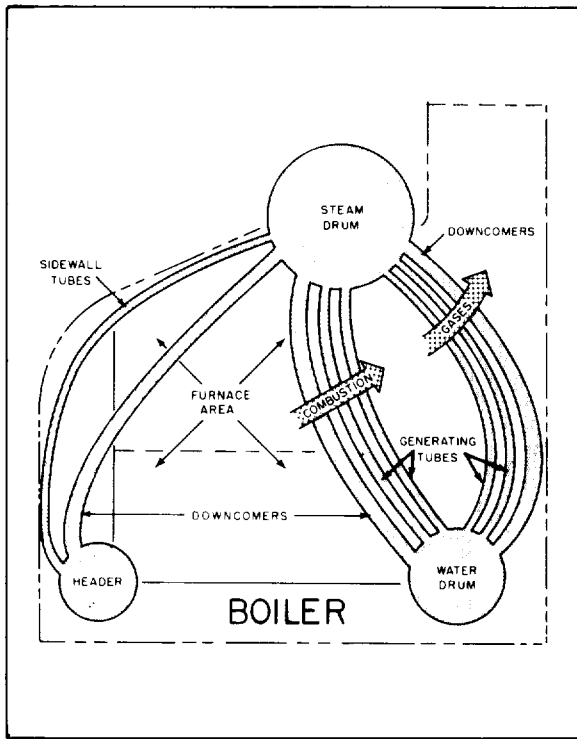

Figure 4-4.—Generating tubes and furnace area.

times the surface area of a 1-inch tube but nine times the volume. The smaller the diameter of the tube, the higher is the ratio of absorption surface to the volume of water.

Normally, only one row of tubes leads from the steam drum to the sidewall header. These are the sidewall (water wall) tubes. Their function is to cool and protect the side wall of the furnace.

So far, we have assembled the drums, header, downcomers, and generating tubes. Before going any further with the assembly, let us trace the path of the water through the boiler.

As the water is heated, it becomes less dense, and steam is formed in the tubes. The water in the steam drum is much cooler than the steam and has greater density. As the hotter water and steam rise through the generating tubes, the cooler more dense water drops through the downcomers to the water drum and headers. The arrows in figure 4-5 show the circulation path of the water as it leaves the steam drum and returns to the steam drum as steam. Notice that the caption under figure 4-5 states that it is an accelerated type. This is indicated by the inclination of the tubes. The tubes

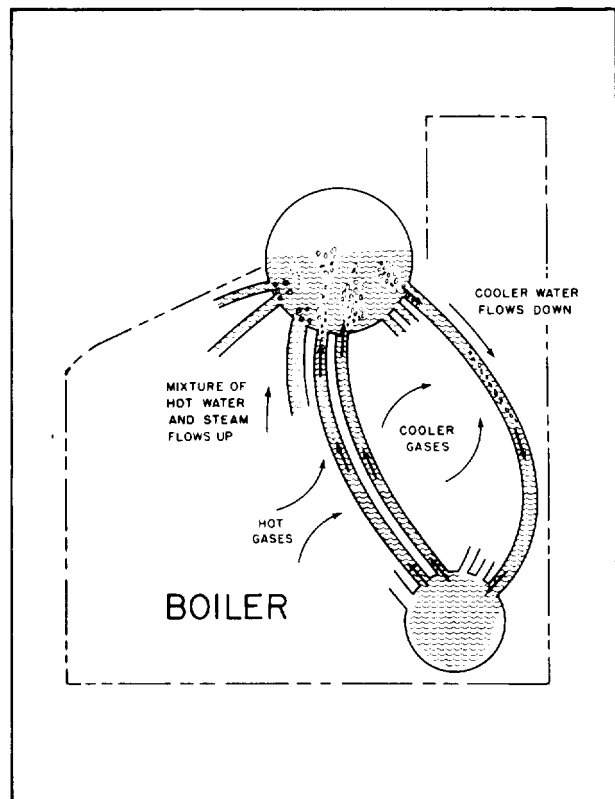

Figure 4-5.—Natural circulation (accelerated type).

shown are almost vertical. The greater the incline, the greater the acceleration.

So far, we have learned how the steam is formed in a boiler. Next, let's find out what happens to the steam once it returns to the steam drum from the generating tubes.

## INTERNAL FITTINGS

Components of the steam drum area are known as INTERNAL FITTINGS. The internal fittings we will discuss are the feedwater distribution, the chemical injection, and the steam and water separator. This equipment is used to direct the flow of steam and water within the steam drum and the desuperheaters, which are located either in the steam drum or the water drum. We will also discuss the economizer in this section. This component is not considered an internal fitting, but its role is important to the function of the steam drum.

The design and arrangement of a steam drum's internal fittings will vary somewhat from

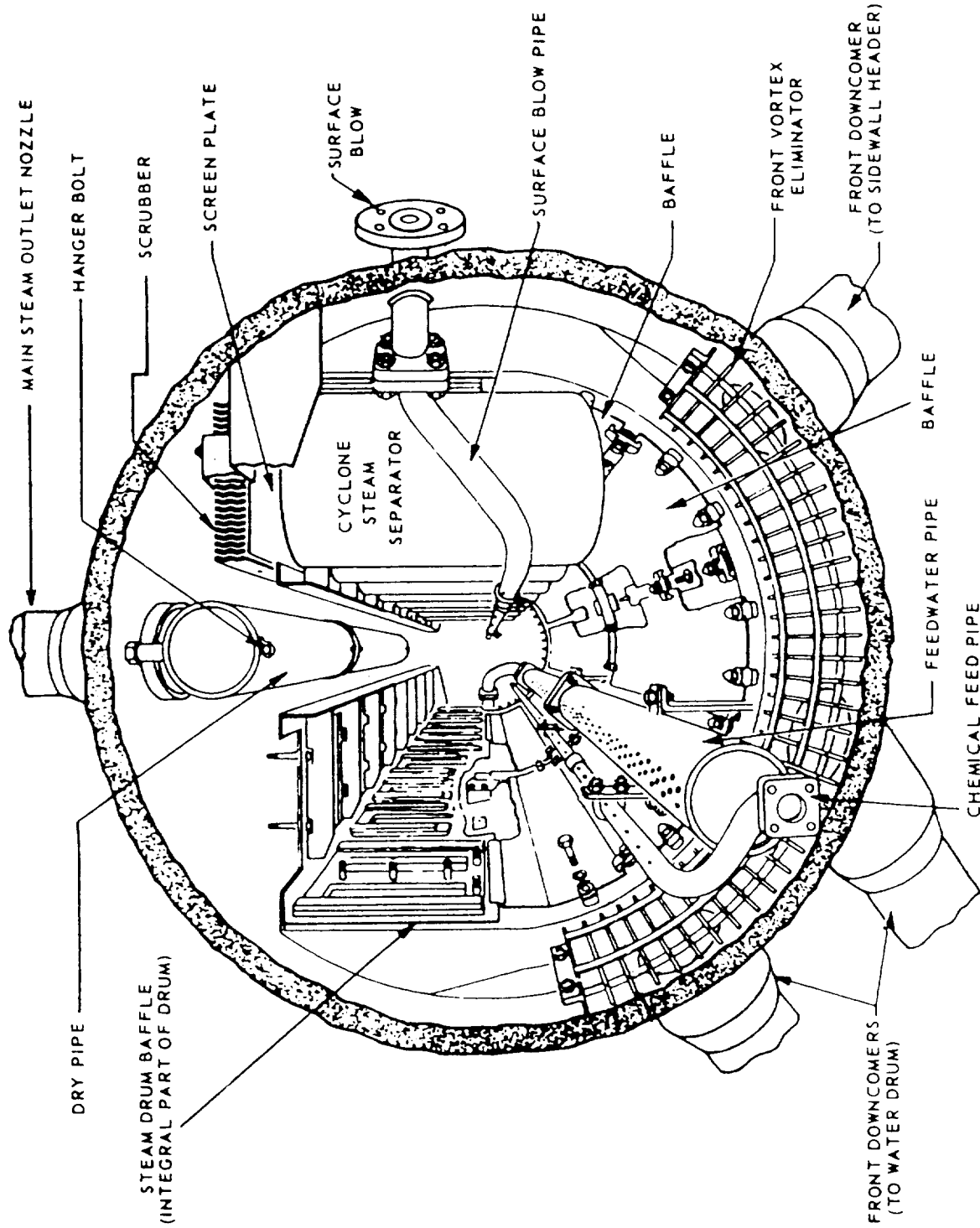

Figure 4-6.—Arrangement of internal fittings in a single-furnace boiler.

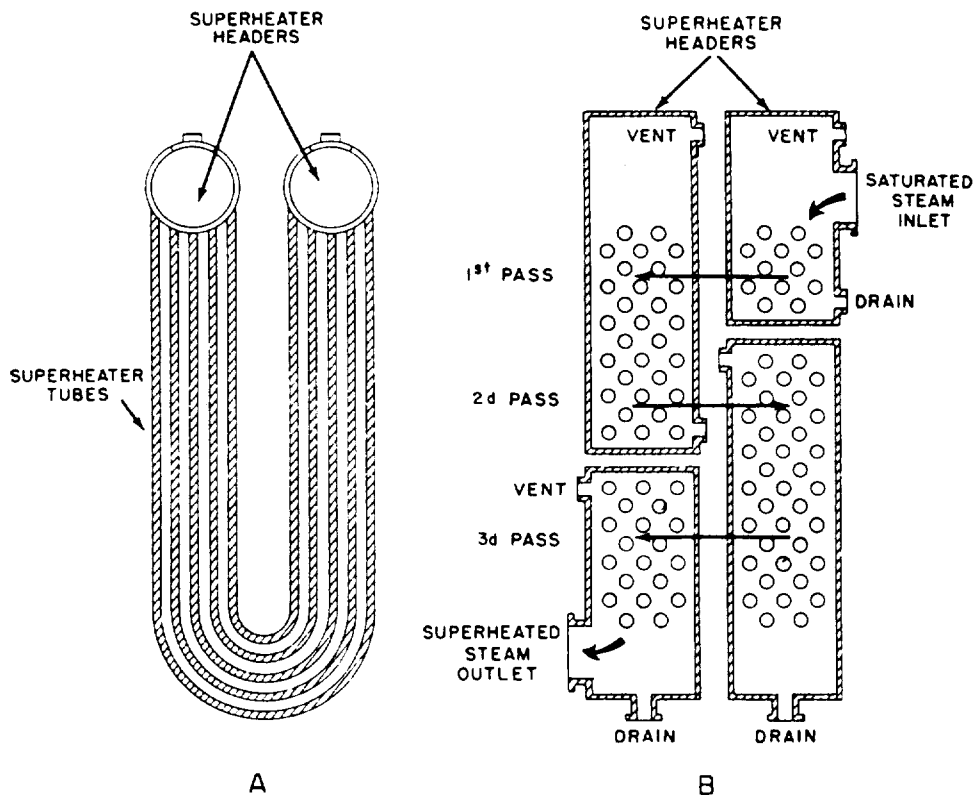

Figure 4-7.—Diagram of a superheater.

one type of boiler to another and from one boiler manufacturer to another. Figure 4-6 shows the arrangement of the steam drum internal fittings in a single-furnace boiler.

- The feedwater pipe receives feedwater from the economizer and distributes it throughout the length of the steam drum.

- The chemical feed pipe is used to inject chemicals into the boiler to maintain the proper pH and phosphate balance in the boiler water.

- The surface blow pipe is used to remove suspended solid matter that floats on top of the water and to lower the steam drum water level, when necessary. The surface blow pipe is also used to blow water out to lower the chemical level in the boiler when it becomes too high.

- The dry pipe is used to direct the steam to the steam drum outlet nozzle after it leaves the scrubbers.

- The vortex eliminators are used to reduce the swirling motion of the water as it enters the downcomers.

- The baffle plates are used to direct the steam to the steam separators.

- The cyclone steam separators remove moisture from the steam. This is accomplished by the steam spinning or changing direction. The water drains back into the steam drum while the steam continues upward through a screen and scrubber that removes still more moisture.

After the steam leaves the scrubbers, it goes to the dry pipe (fig. 4-6). From there it leaves the steam drum through the steam drum outlet. Figure 4-7, view A, shows the steam going to the inlet header of the superheater and passing through the U-shaped tubes of the superheater to the next header (fig. 4-7, view B). This header is called the first pass or intermediate header. Steam may pass through the U-shaped tubes several times before passing to the outlet header. Each time the steam goes from one header to the next header it is called a pass. The number of passes the steam makes in a superheater varies with different boilers and the degree of superheat that is required for a particular ship.

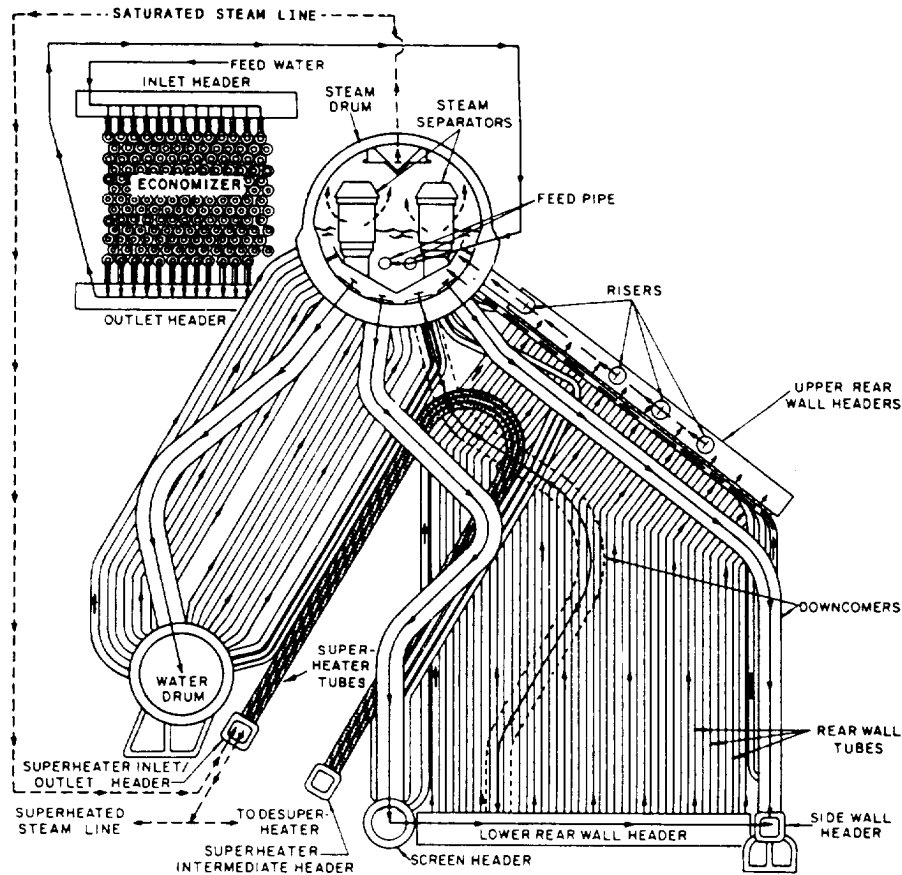

Figure 4-8.—Vertical superheater.

As the steam passes through the superheater tubes, it is heated by the hot gases from combustion, which flow around the tubes.

In some boilers, the superheater headers are installed parallel with the water drum; and the tubes are installed vertically (fig. 4-8). These are called vertical superheaters.

Another boiler internal fitting is the desuperheater. It may be located either in the steam drum or in the water drum. All the steam generated in a single-furnace boiler is led through the superheater. However, since some auxiliary machinery is not designed for superheated steam, the steam must be cooled down. This is done with a desuperheater. The desuperheater gets steam from the superheater outlet, as shown in figure 4-9. The desuperheater is submerged in water either in the steam drum or in the water drum. As the steam passes through the desuperheater, it is cooled for use in the auxiliary steam systems.

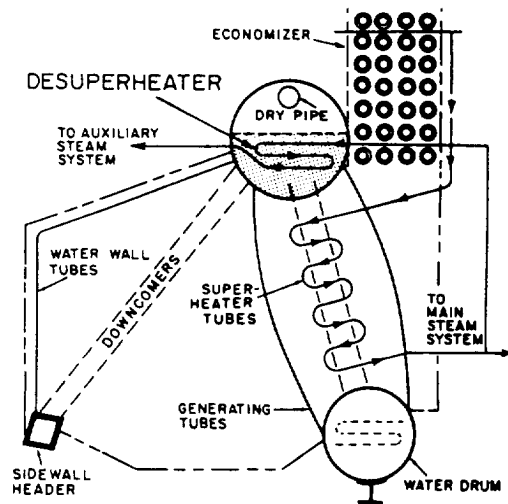

Figure 4-9.—Relative position of desuperheater tubes.

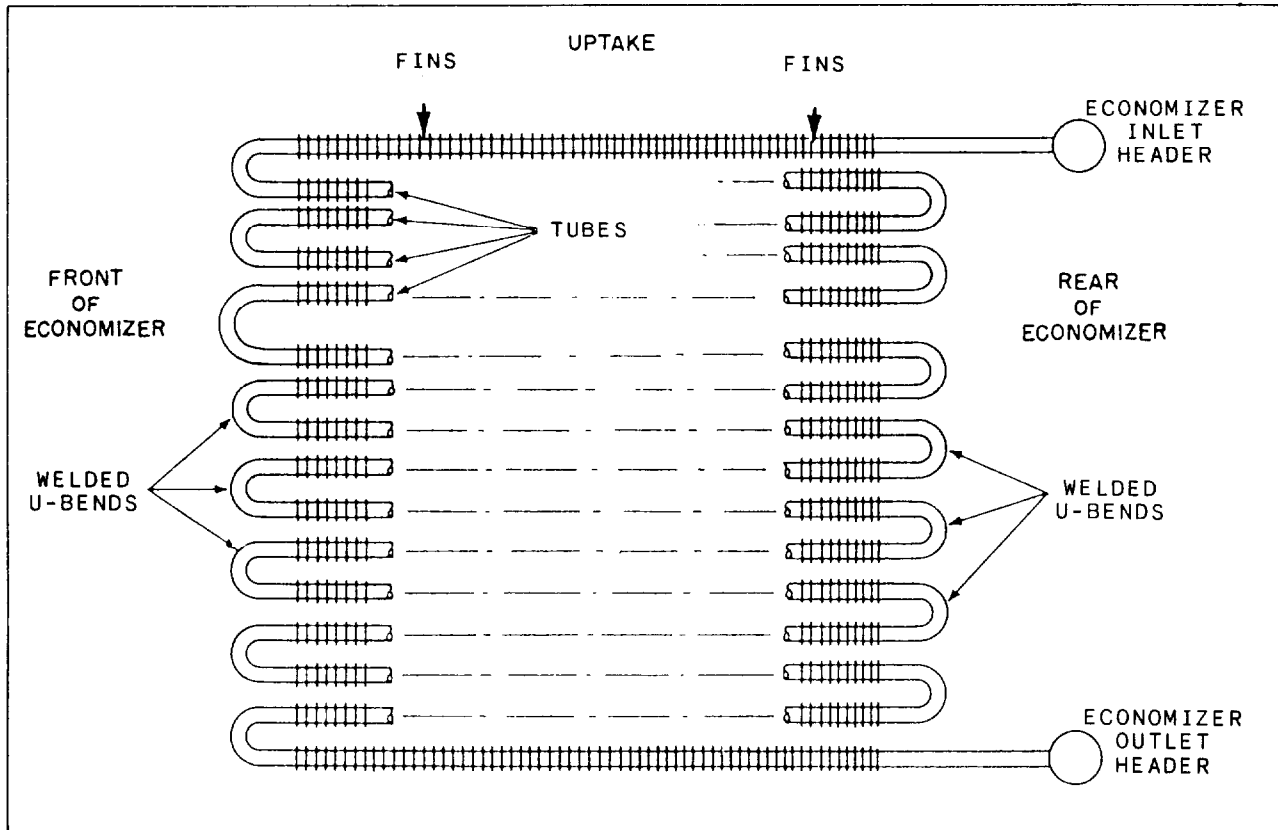

Figure 4-10.—Side view of an economizer.

It is important that all internal fittings are properly installed and in good working condition. If excessive moisture is carried over into the superheater, serious damage will result in the superheater tubes, piping, and turbines.

The economizer (fig. 4-10) is an arrangement of tubes installed in the uptake space from the furnace. The economizer tubes have metal projections from the outer tube surfaces. These projections are called by various names, including FINS, STUDS, RINGS, or GILL RINGS. They are made of aluminum, steel, or other metals, in a variety of shapes. These projections serve to extend the heat transfer surface of the tubes on which they are installed.

Before entering the steam drum, all feedwater flows through the economizer tubes. The economizer tubes are heated by the rising gases of combustion. The feedwater is warmed or preheated by the combustion gases that would otherwise be wasted as they pass up the stack.

In figure 4-1 you can see that the economizer is positioned on top of the boiler. There it acts as a preheater.

So far, you have learned how the water gets to the boiler and what happens while it's there. Next, let's find out how the water is heated, where the heat comes from, and what boiler components are necessary for generating this heat.

## FURNACE

The furnace, or firebox, is the large, room-like space where air and fuel are mixed for the combustion (fire) that heats the water in the drums, tubes, and headers.

The furnace is more or less a rectangular steel casing that is lined on the floor and walls with refractory (heat-resisting) material. Refractory materials used in naval boilers include firebrick, insulating brick, insulating block, and air-setting

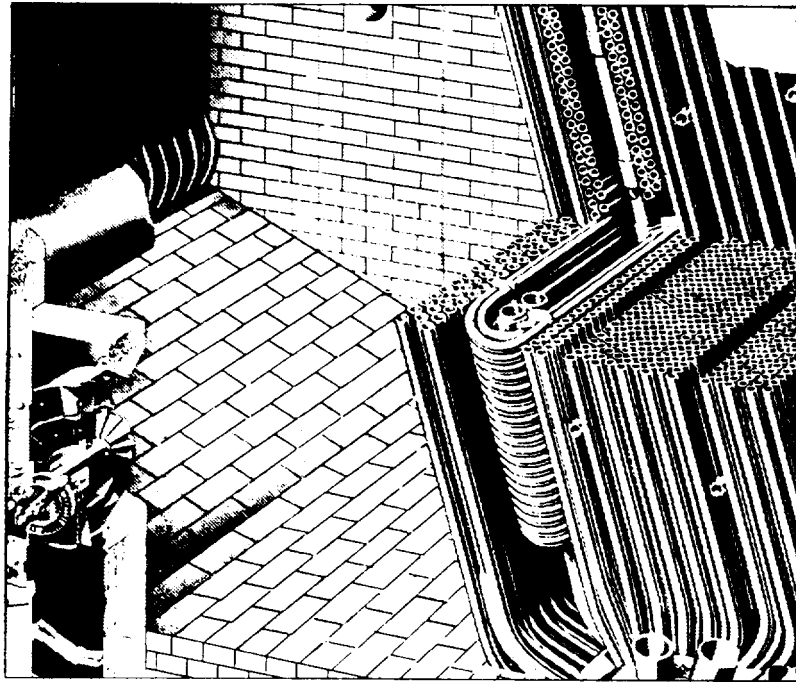

Figure 4-11.—Refractory-lined furnace.

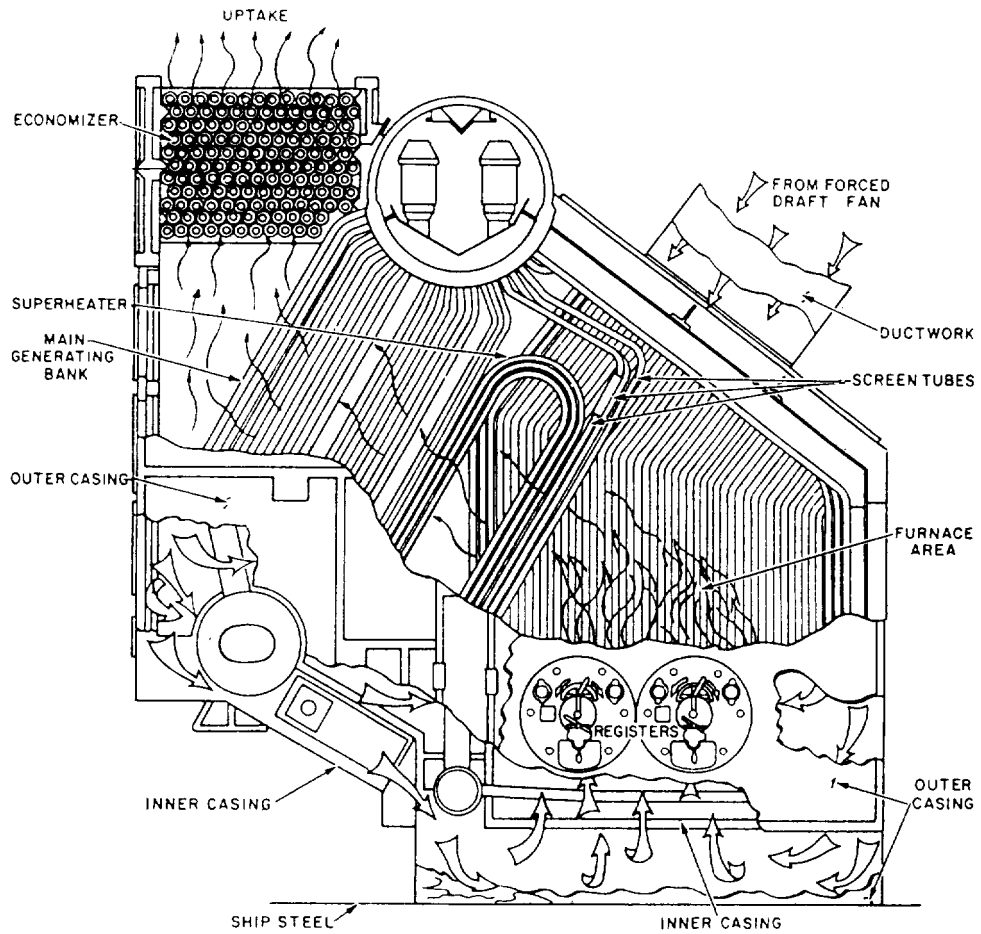

Figure 4-12.—Combustion air and gas flow.



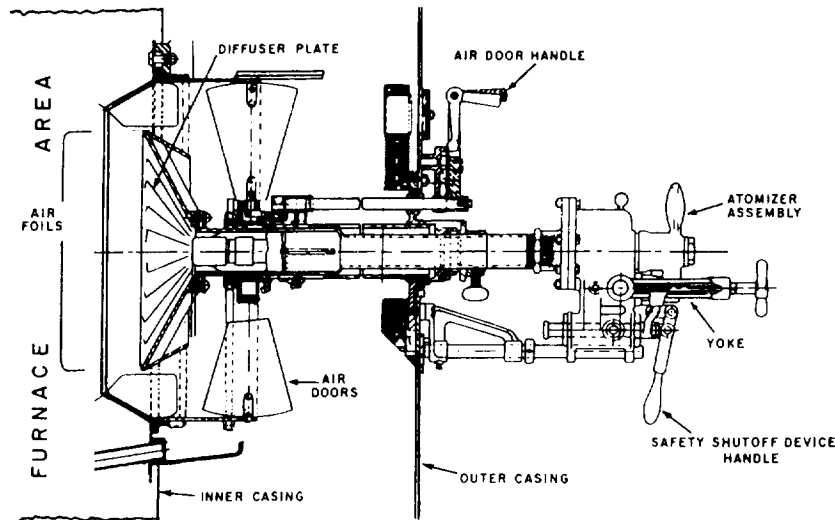

Figure 4-13.—Fuel-oil burner assembly.

mortar. Figure 4-11 shows a refractory-lined furnace.

The refractory lining protects the furnace steel casing and prevents the loss of heat from the furnace. The lining also retains heat for a relatively long time and helps to maintain the high furnace temperatures that are needed for complete fuel combustion.

### Combustion Air

Air is forced into the furnace by a forced draft blower. The forced draft blower is a large volume fan that can be powered by an electric motor or a steam turbine. The forced draft blower blows air into the outer casing of the boiler (fig. 4-12). The air then travels between the inner casing and outer casing to the boiler front where it is forced into the furnace through the air registers. The air registers are part of the fuel-oil burner assembly that consists of four main parts: air doors, a diffuser, air foils, and the atomizer assembly. Figure 4-13 shows a side view of a fuel-oil burner assembly.

**AIR REGISTERS.**— The air entering the furnace through the air registers mixes with a fine fuel-oil spray through the atomizer. Figure 4-13 shows the arrangement of an air register in a fuel-oil burner assembly. The air doors are used to open or close the register, as necessary. They are usually kept either fully opened or fully closed. When the air doors are open, air rushes in and is given a whirling motion by the diffuser plate. The diffuser plate causes the air to mix evenly with the atomized oil in such a way that the flame will not blow away from the atomizer (atomizers are

discussed in the next paragraph). The air foils guide the major quantity of air so it mixes with the larger particles of fuel oil spray beyond the diffuser.

**ATOMIZERS.**— Atomizers (devices for producing a fine spray) break up the fuel oil into very fine particles. In the following paragraphs we will briefly discuss the three types of atomizers. These three types are the return-flow atomizer, the steam-assist atomizer, and the vented-plunger atomizer.

**Return-Flow Atomizer.**— The return-flow atomizer provides a constant supply of fuel-oil pressure. Any fuel oil not needed to meet steam demand is returned to the fuel-oil service tank. This is accomplished by the return control valve installed in the piping between the boiler front and the service tank. As the return control valve is closed, more fuel oil is forced through the sprayer plate into the furnace. The return-flow atomizer is shown in figure 4-14.

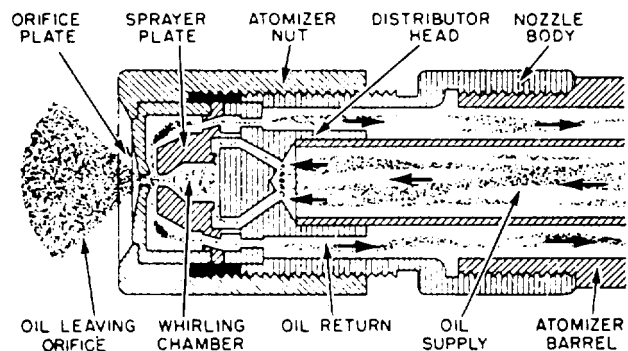

Figure 4-14.—Return-flow atomizer.

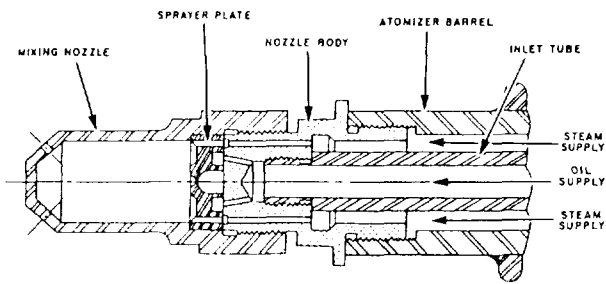

Figure 4-15.—TODD LVS atomizer.

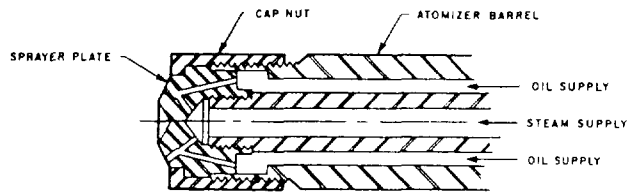

Figure 4-16.—Y-Jet steam atomizer.

**Steam-Assist Atomizer.**— The steam-assist atomizer employs 150 psi of steam mixed with the fuel oil to help atomize the fuel oil. The two most common steam-assist atomizers in use by the Navy are the TODD LVS (fig. 4-15) and the Y-Jet (fig. 4-16). All steam-assist atomizers must have low-pressure air hookup for use as a substitute when suitable auxiliary steam is not available.

**Vented-Plunger Atomizer.**— The vented-plunger atomizer shown in figure 4-17 is unique in that it is the only atomizer in use in the Navy that has moving parts. The fuel oil flows down the atomizer barrel and around the atomizer cartridge. The pressure in the barrel forces the fuel oil into the cartridge through the holes drilled in the cartridge. As the fuel is forced into the cartridge, it begins to spin. This motion forces the fuel out through the orifice in a fine mist. Increasing fuel-oil pressure in the atomizer barrel and cartridge will cause the piston to overcome the spring pressure. The piston is then forced back, uncovering more holes and allowing fuel to be atomized and forced into the furnace. As pressure decreases, the opposite occurs. The spring tension recalls the piston, covering the holes and allowing less fuel oil to be atomized.

#### Fire

In most boilers, a torch is used to light fires. However, some boilers may have electric igniters.

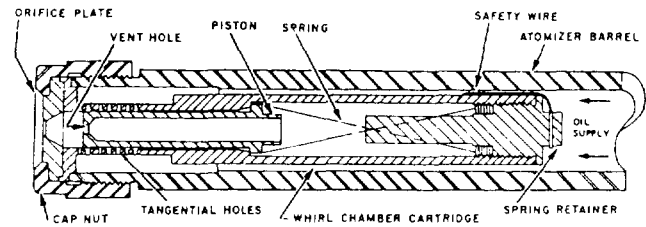

Figure 4-17.—Vented-plunger atomizer.

We will describe the more common method—lighting fires with a torch.

Boiler light off is always a two-person operation. One person is needed to handle the torch, the air register, and the furnace, and the other to open the fuel-oil root valve. If fires do not light in 2 or 3 seconds, you must secure the fuel oil and investigate the reason for the failure to light. The boiler furnace must be inspected and repurged before the next attempt to light.

The basic light-off procedure involves the following steps:

1. Ensure that all fuel-oil manifold and atomizer/safety shut-off valves are shut.
2. Insert a clean atomizer with a lighting-off sprayer plate into the No. 1 burner.
3. Adjust the combustion air and fuel-oil pressures for lighting the fires.
4. Ignite the lighting-off torch.
5. Insert the lighted torch into the lighting-off port and close the port cover; visually check to ensure that the torch remains lighted. However, you should never insert a torch into a furnace until you are sure that no fuel is on the furnace deck and that the boiler has been purged of all combustible gases.
6. Open the No. 1 burner fuel-oil atomizer/safety shut-off valve(s).
7. Open the No. 1 burner fuel-oil supply manifold valve one-half turn.
8. Observe the furnace through the No. 1 burner observation port to ensure that the ignition is successful.
9. Adjust the flame with the burner air register handle.
10. Open the No. 1 burner fuel-oil supply manifold to the fully open position.
11. Withdraw and extinguish the torch.

For specific lighting-off instructions, always refer to your ship's EOSS.

The following are a few simple suggestions to make your job easier and safer:

- Do not operate any valves or start equipment until you have permission from the EOOW or EDO, and always refer to the EOSS.
- Always clean up any spills or debris.
- Report to your supervisor any condition that you think may be abnormal.
- Do not be afraid to ask questions!

### **AUXILIARY BOILER**

An auxiliary boiler is a small boiler that supplies steam for distilling plants, space heating, oil heating, water heating, galley, and laundry. These boilers have all the auxiliaries, accessories, and controls to form a unit assembly. They are arranged to operate as complete self-contained, steam-generating plants. For further information

on auxiliary boilers, refer to *Naval Ships' Technical Manual*, S9086-GY-STM-000, chapter 221, section 5.

### **WASTE-HEAT BOILERS**

On some classes of ships, you may find waste-heat boilers. Waste-heat boilers are used by the *Spruance* class and *Ticonderoga* class CGs. These boilers supply the steam for ship's services by using the hot exhaust gases from the gas turbine generator sets (GTGSs). For further information on waste-heat boilers, refer to *GSM 3 & 2*, NAVEDTRA 10548-2, chapter 6.

### **SUMMARY**

In this chapter we have discussed boiler terminology, construction, types, components, and function. To help you understand this information, go down to the fireroom on your ship and ask a BT to show and explain to you the things you have just read about. This should help your retention of the information you have studied and perhaps provide you with additional knowledge on boilers.



## CHAPTER 5

# STEAM TURBINES

In previous chapters we discussed the basic steam cycle and various types of naval boilers. At this point, we will bring together all you have learned by discussing the components inside the turbine casing.

In the following paragraphs we will discuss turbine theory, types and classifications of turbines, and turbine construction.

Upon completion of this chapter you will understand how stored energy (heat) in steam is transformed to mechanical energy (work).

### TURBINE THEORY

The first documented use of steam power is credited to a Greek mathematician, Hero of Alexandria, almost 2000 years ago. Hero built the first steam-powered engine. His turbine design was the forerunner of the jet engine and demonstrated that steam power could be used to operate other machinery. Hero's turbine (aeolipile) (fig. 5-1) consists of a hollow sphere and four canted nozzles. The sphere rotates freely on two feed tubes that carry steam from the boiler. Steam generated in the boiler passes through the feed tubes, into the sphere, and out through the nozzles. As the steam leaves the nozzles, the sphere rotates rapidly.

Down through the ages, the application of the turbine principle has been used in many different types of machines. The water wheel that was used to operate the flour mills in colonial times and the common windmill used to pump water are examples of the turbine principle. In these examples, the power comes from the effect of the wind or a stream of water acting on a set of blades. In a steam

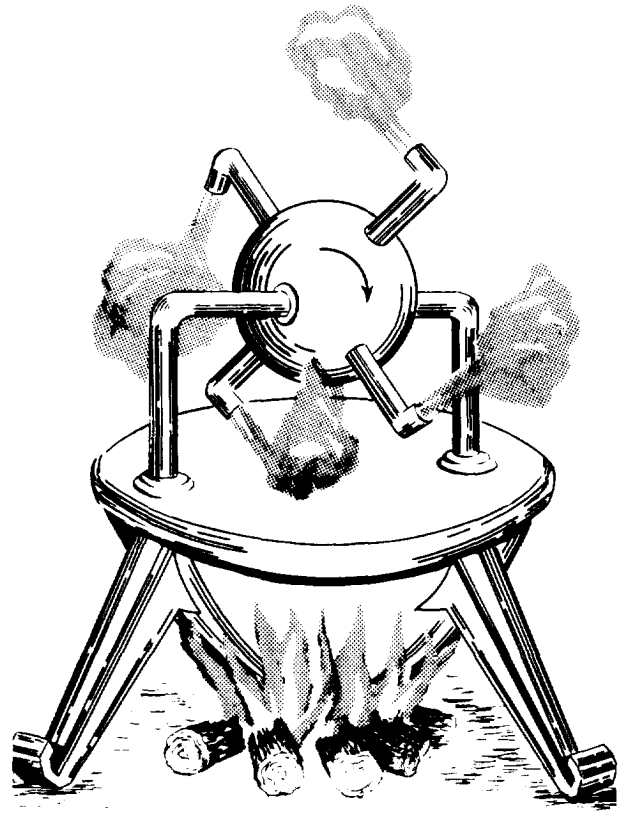

Figure 5-1.—Hero's turbine (aeolipile).

turbine, steam serves the same purpose as the wind or the flowing water.

Two methods are used in turbine design and construction to get the desired results from a turbine. These are the impulse principle and the reaction principle. Both methods convert the thermal energy stored in the steam into useful work, but they differ somewhat in the way they do it. In the following paragraphs we will discuss the two basic turbine principles, the impulse and reaction.

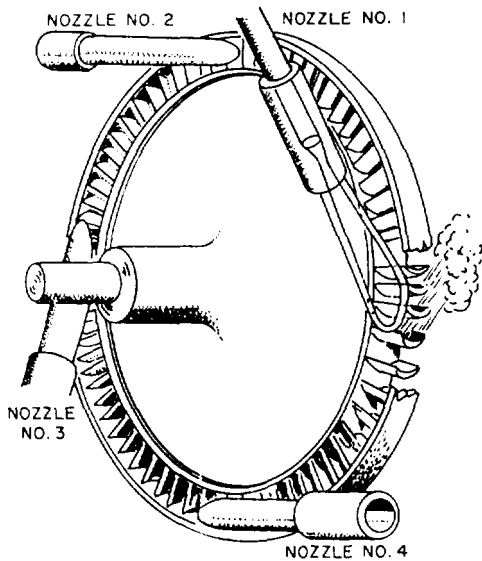

Figure 5-2.—Impulse turbine.

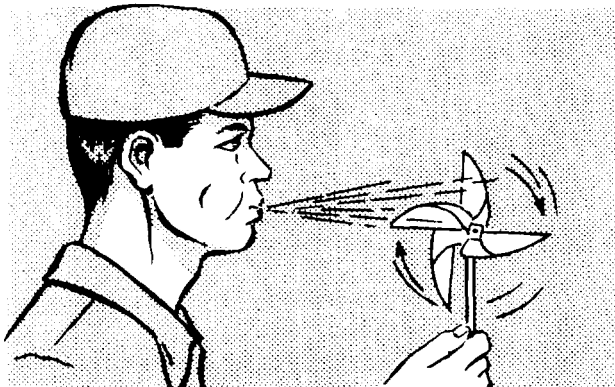

Figure 5-3.—Simple impulse turbine principle.

## IMPULSE PRINCIPLE

The impulse turbine (fig. 5-2) consists basically of a rotor mounted on a shaft that is free to rotate in a set of bearings. The outer rim of the rotor carries a set of curved blades, and the whole assembly is enclosed in an airtight case. Nozzles direct steam against the blades and turn the rotor.

The energy to rotate an impulse turbine is derived from the kinetic energy of the steam flowing through the nozzles. The term *impulse* means that the force that turns the turbine comes

from the impact of the steam on the blades. The toy pinwheel (fig. 5-3) can be used to study some of the basic principles of turbines. When you blow on the rim of the wheel, it spins rapidly. The harder you blow, the faster it turns. The steam turbine operates on the same principle, except it uses the kinetic energy from the steam as it leaves a steam nozzle rather than air.

Steam nozzles (hereafter referred to as nozzles or stationary blades) are located at the turbine inlet. As the steam passes through a nozzle, potential energy is converted to kinetic energy. This steam is directed toward the turbine blades and turns the rotor. The velocity of the steam is reduced in passing over the blades. Some of its kinetic energy has been transferred to the blades to turn the rotor.

Impulse turbines may be used to drive forced draft blowers, pumps, and main propulsion turbines.

Figure 5-2 shows an impulse turbine as steam passes through the nozzles.

## REACTION PRINCIPLE

The ancient turbine built by Hero operated on the reaction principle. Hero's turbine was invented long before Newton's time, but it was a working model of Newton's third law of motion, which states: *"For every action there must be an equal and opposite reaction."*

If you set an electric fan on a roller skate, the roller skate will take off across the room (fig. 5-4). The fan pushes the air forward and sets up a breeze (velocity). The air is also pushing backward on the fan with an equal force, but in an opposite direction.

If you try to push a car, you will push back with your feet as hard as you would push forward with your hands. Try it sometime when you are standing on an icy road. You will not be able to move the car unless you can dig in with your feet to exert the backward force. With some thought on your part, you could come up with examples to prove to yourself that Newton's third law of motion holds true under all circumstances.

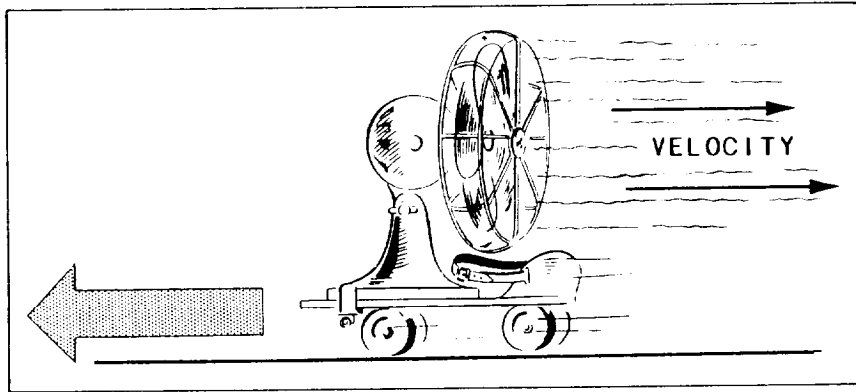

Figure 5-4.—Demonstration of the velocity of the reaction principle.

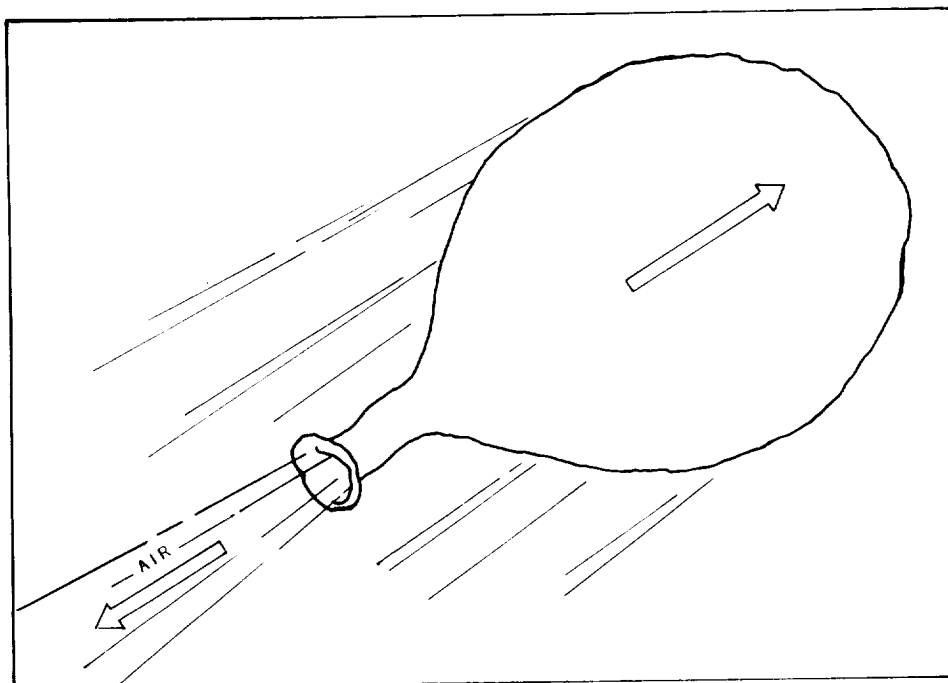

Figure 5-5.—Demonstration of the kickback of the reaction principle.

The reaction turbine uses the reaction of a steam jet to drive the rotor. You learned that an impulse turbine increases the velocity of steam and transforms that potential energy under pressure into kinetic energy in a steam jet through nozzles. A forward force is applied to the steam to increase its velocity as it passes through the nozzle. From Newton's third law of motion, you see that the steam jet exerts a force on the nozzle and an equal reactive force on the turbine blades in the opposite direction. **THIS IS THE FORCE THAT DRIVES THE TURBINE.**

In the reaction turbine, stationary blades attached to the turbine casing act as nozzles and direct the steam to the moving blades. The moving blades mounted on the rotor act as nozzles. Most reaction turbines have several alternating rows of stationary and moving nozzle blades.

You can use a balloon to demonstrate the kickback or reaction force generated by the nozzle blades (fig. 5-5). Blow up the balloon and release it. The air will rush out through the

opening and the balloon will shoot off in the opposite direction.

When the balloon is filled with air, you have potential energy stored in the increased air pressure inside. When you let the air escape, it passes through the small opening. This represents a transformation from potential energy to kinetic energy. The force applied to the air to speed up the balloon is acted upon by a reaction in the opposite direction. This reactive force propels the balloon forward through the air.

You may think that the force that makes the balloon move forward comes from the jet of air blowing against the air in the room, not so. It is the reaction of the force of the air as it passes through the opening that causes the balloon to move forward.

The reaction turbine has all the advantages of the impulse-type turbine, plus a slower operating

speed and greater efficiency. The alternating rows of fixed and moving blades transfers the heat energy of the steam to kinetic energy, then to mechanical energy.

We have discussed the simple impulse and reaction turbines. Practical applications require various power outputs. Turbines are constructed with one or more simple turbines made as one. This is done in much the same way that the varying cylinder size of a car engine varies power. Figures 5-6 and 5-7 show typical naval turbines.

### TURBINE CLASSIFICATION

So far we have classified turbines into two general groups: **IMPULSE TURBINES** and **REACTION TURBINES**, depending on the method used to cause the steam to do useful

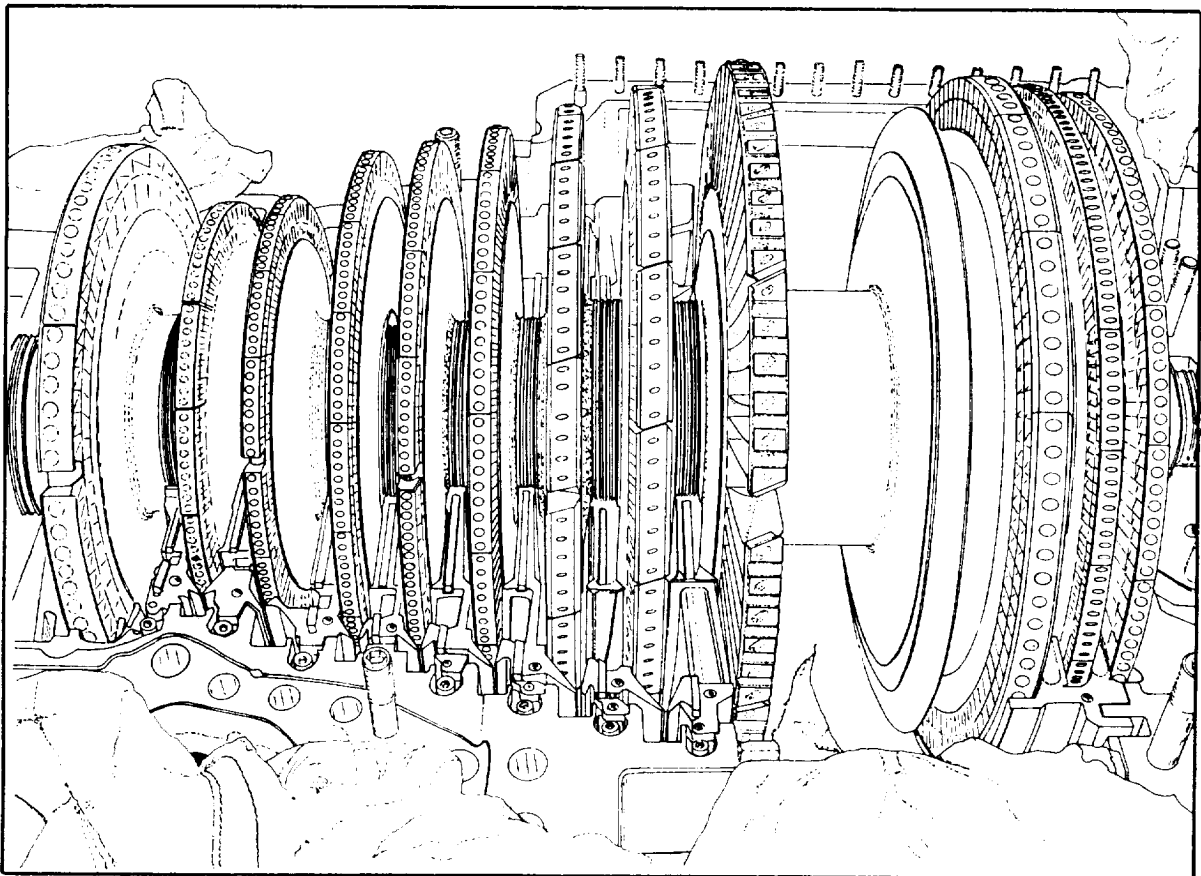

Figure 5-6.—Impulse main propulsion turbine.

139.58



work. Turbines may be further classified according to the following:

- Type and arrangement of staging
- Direction of steam flow
- Repetition of steam flow
- Division of steam flow

A turbine may also be classified by whether it is a condensing unit (exhaust to a condenser at a pressure below atmospheric pressure) or a non-condensing unit (exhausts to another system such as the auxiliary exhaust steam system at a pressure above atmospheric pressure).

### CONSTRUCTION OF TURBINES

Other than the operating and controlling equipment, similarity exists in both the impulse and reaction turbines. These include foundations, casings, nozzles, rotors, bearings, and shaft glands.

### Foundations

Turbine foundations are built up from a structural foundation in the hull to provide a rigid supporting base. All turbines are subjected to varying degrees of temperature—from that existing during a secured condition to that existing during full-power operation. Therefore, means are provided to allow for expansion and contraction.

At the forward end of the turbine, there are various ways to give freedom of movement. Elongated bolt holes or grooved sliding seats are used so that the forward end of the turbine can move fore and aft as either expansion or contraction takes place. The forward end of the turbine may also be mounted with a flexible I-beam that will flex either fore or aft.

### Casings

The materials used to construct turbines will vary somewhat depending on the steam and power conditions for which the turbine is designed. Turbine casings are made of cast carbon steel for nonsuperheated steam applications. Superheated

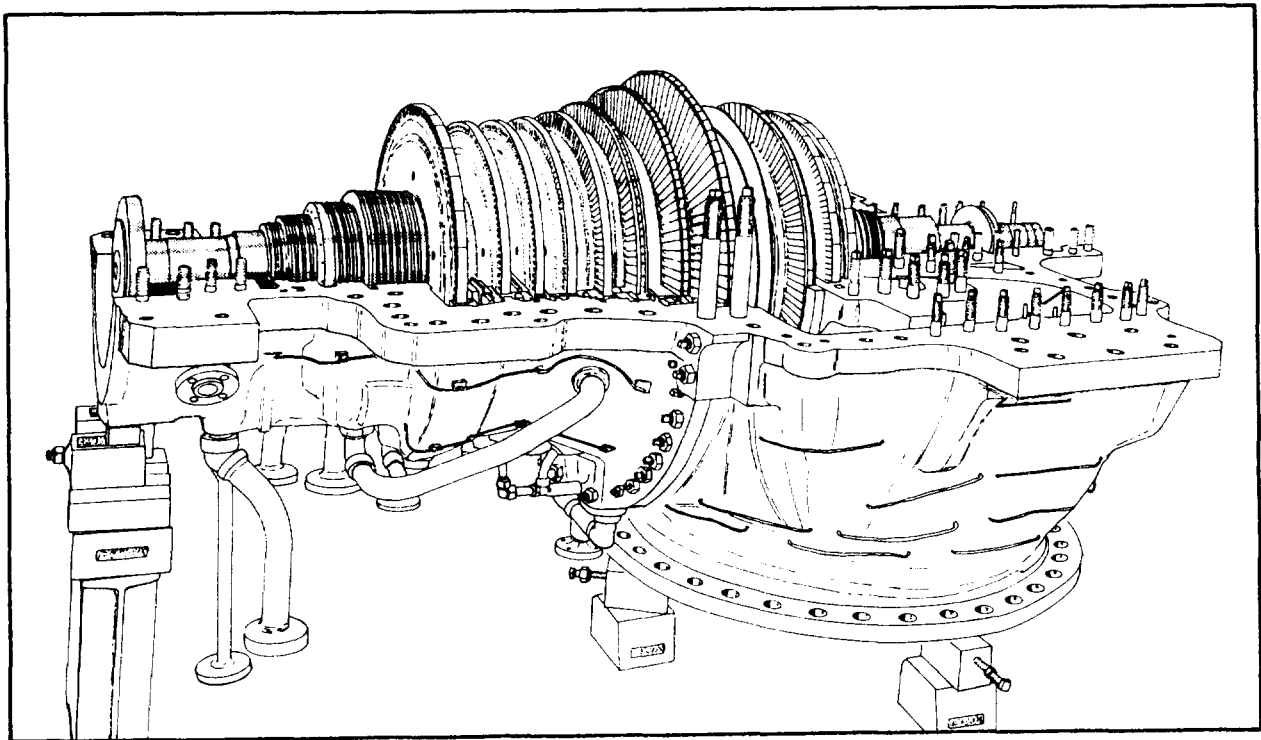

Figure 5-7.—Turbine assembly in a machine shop.

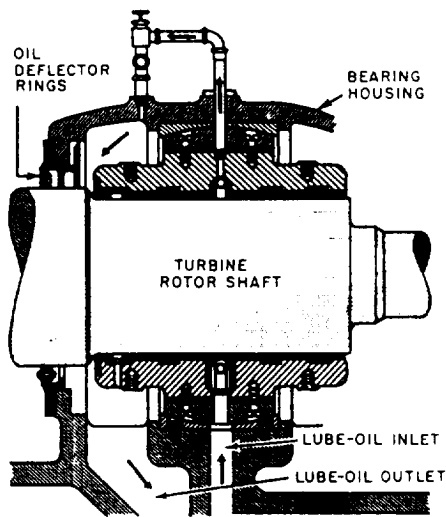

Figure 5-8.—Typical sliding surface bearing.

applications use casings made of carbon molybdenum steel. For turbine casings used on submarines, a percentage of chrome stainless steel is used, which is more resistant to steam erosion than carbon steel. Each casing has a steam chest to receive the incoming high-pressure steam. This steam chest delivers the steam to the first set of nozzles or blades.

### Nozzles

The primary function of the nozzles is to convert the thermal energy of steam into kinetic energy. The secondary function of the nozzles is to direct the steam against the blades.

### Rotors

Rotors (forged wheels and shaft) are manufactured from steel alloys. The primary purpose of a turbine rotor is to carry the moving blades that convert the steam's kinetic energy to rotating mechanical energy.

### Bearings

The rotor of every turbine must be positioned radially and axially by bearings. Radial bearings carry and support the weight of the rotor and maintain the correct radial clearance between the rotor and casing.

Axial (thrust) bearings limit the fore-and-aft travel of the rotor. Thrust bearings take care of

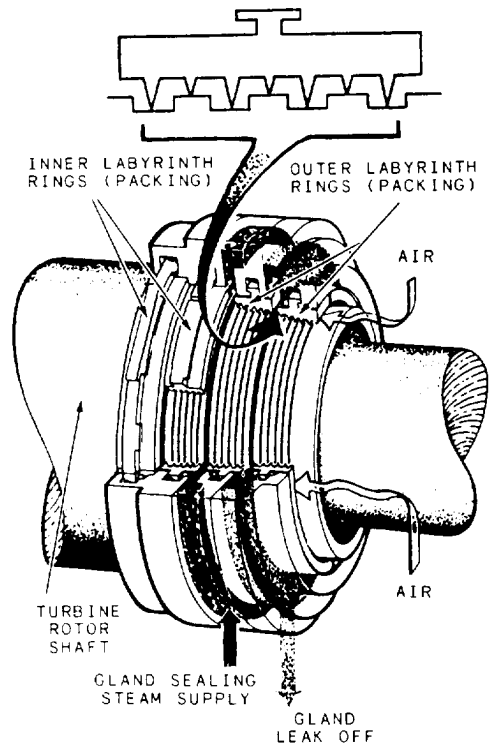

Figure 5-9.—Labyrinth packing gland.

any axial thrust, which may develop on a turbine rotor and hold the turbine rotor within definite axial positions.

All main turbines and most auxiliary units have a bearing at each end of the rotor. Bearings are generally classified as sliding surface (sleeve and thrust) or as rolling contact (antifriction ball or roller bearings). Figure 5-8 shows a typical sliding surface bearing.

### Shaft Packing Glands

Shaft packing glands prevent the leaking of steam out of or air into the turbine casing where the turbine rotor shaft extends through the turbine casing. Labyrinth and carbon rings are two types of packing. They are used either separately or in combination.

Labyrinth packing (fig. 5-9) consists of rows of metallic strips or fins. The strips fasten to the gland liner so there is a small space between the strips and the shaft. As the steam from the turbine casing leaks through the small space between the packing strips and the shaft, steam pressure gradually reduces.

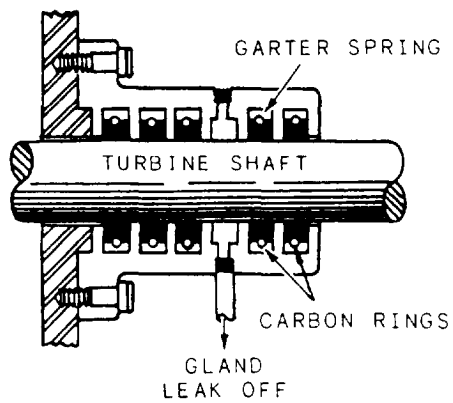

Figure 5-10.—Carbon packing gland.

Carbon packing rings (fig. 5-10) restrict the passage of steam along the shaft in much the same manner as labyrinth packing strips. Carbon packing rings mount around the shaft and are held in place by springs.

Three or four carbon rings are usually used in each gland. Each ring fits into a separate compartment of the gland housing and consists of two, three, or four segments that are butt-jointed to each other. A garter spring is used to hold these segments together. The use of keepers (lugs or stop pins) prevent the rotation of the carbon rings when the shaft rotates. The outer carbon ring compartment connects to a drain line.

### SUMMARY

In this chapter, you have learned about the components inside a steam turbine casing. You have also learned the basics of how the steam turbine works. For more information on steam turbines, refer to *Machinist's Mate 3 & 2*, NAVEDTRA 10524-F1, chapter 2.



## CHAPTER 6

# GAS TURBINES

This chapter will provide you with a basic understanding of the history and development of gas turbine engines. This chapter will also discuss basic gas turbine engine theory, types, construction features, and operating principles.

### HISTORY AND BACKGROUND

Until recent years, it has not been possible to separate gas turbine and jet engine technology. The same people worked in both fields, and the same sciences were applied to both types of engines. Recently, the jet engine has been used more exclusively as a part of aviation. The gas turbine has been used for the generation of electricity, ship propulsion, and experimental automobile propulsion. Many operational turbine power plants use aircraft jet engines as a gas generator (GG), adding a power turbine (PT) and transmission to complete the plant.

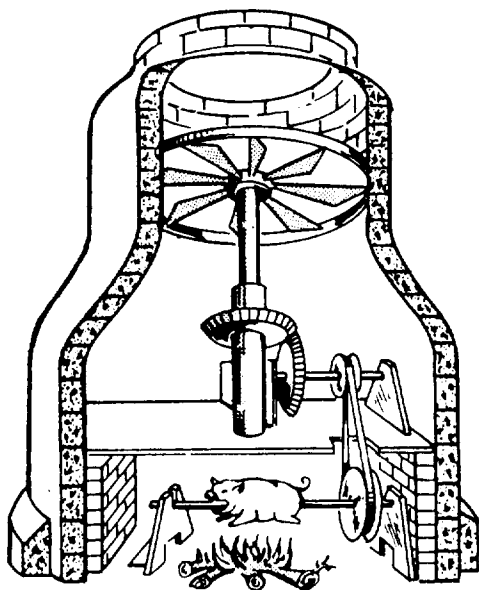

Figure 6-1.—DaVinci's chimney jack.

In the last chapter we discussed Hero, a scientist from Alexandria, Egypt. Many sources credit him as the inventor of the *aeolipile* (see chapter 5, fig. 5-1). The *aeolipile* is considered by many sources to be the first turbine engine.

Throughout the course of history, there are examples of other devices that used the principle of expanding gases to perform work. Among these were inventions of Leonardo DaVinci (fig. 6-1) and Giovanni Branca (fig. 6-2).

In the 1680s, Sir Isaac Newton described the laws of motion. All devices that use the theory of jet propulsion are based on these laws. Newton's steam wagon is an example of his reaction principle (fig. 6-3).

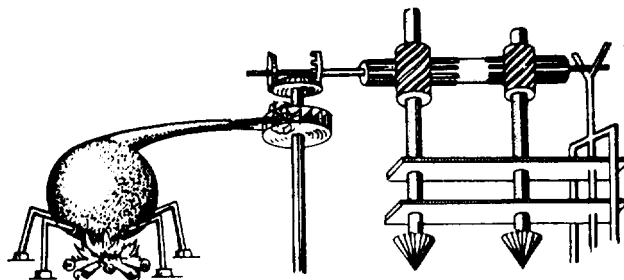

Figure 6-2.—Branca's jet turbine.

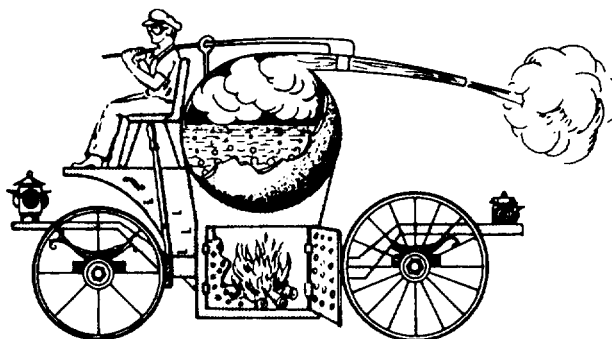

Figure 6-3.—Newton's steam wagon.

## TWENTIETH-CENTURY DEVELOPMENT

The patent application for the gas turbine, as we know it today, was submitted in 1930 by an Englishman, Sir Frank Whittle. His patent was for a jet aircraft engine. Using his ideas, along with the contributions of such scientists as Coley and Moss, Whittle developed a working gas turbine engine (GTE).

## AMERICAN DEVELOPMENT

The United States entered the gas turbine field in late 1941 when General Electric was awarded a contract to build an American version of a foreign-designed aircraft (gas turbine) engine. The engine and airframe were both built in 1 year. The first jet aircraft was flown in this country in October 1942.

In late 1941, Westinghouse Corporation was awarded a contract to design and build from scratch the first all-American gas turbine engine. Their engineers designed the first axial-flow compressor and annular combustion chamber. Both of these ideas, with minor changes, are the basis for the majority of gas turbine engines in use today.

## MARINE GAS TURBINES

The concept of using a gas turbine to propel a ship goes back to 1937 when a Pescara

free-piston gas engine was used experimentally with a gas turbine. The free-piston engine, or "gasifier" (fig. 6-4), is a form of diesel engine that uses air cushions instead of a crankshaft to return the pistons. It was an effective producer of pressurized gases, and the German Navy used it in their submarines during World War II as an air compressor. In 1953, the French placed in service two small vessels powered by a free-piston engine/gas turbine combination. In 1957, the United States put into service the liberty ship *William Patterson*, having six free-piston engines driving two turbines.

The gasifier, or compressor, was usually an aircraft jet engine or turboprop front end. In 1947, the Motor Gun Boat 2009, of the British navy, used a 2500 horsepower (hp) gas turbine to drive the center of three shafts. In 1951, in an experimental application, the tanker *Auris* replaced one of four diesel engines with a 1200 hp gas turbine. In 1956, the *John Sergeant* had a remarkably efficient installation that used a regenerator to recover heat from the exhaust gases.

By the late 1950s, gas turbine marine engines were becoming widely used in combination with conventional propulsion equipment mostly by European navies. Gas turbines were used for high-speed operation, and conventional plants were used for cruising. The most common arrangements were the combined diesel or gas turbine (CODOG) or the combined diesel and gas turbine (CODAG) systems. Diesel engines give good

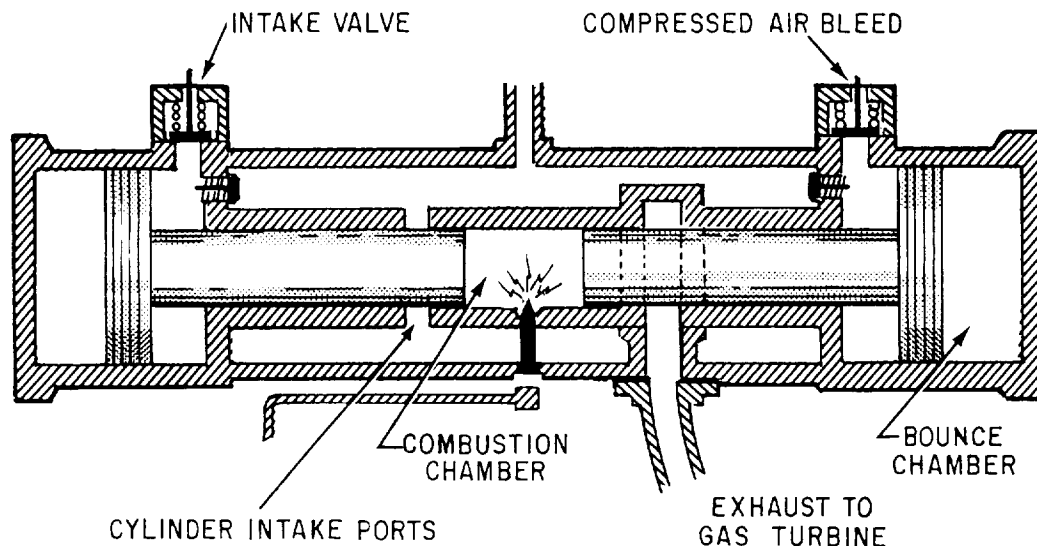

Figure 6-4.—Free-piston engine.

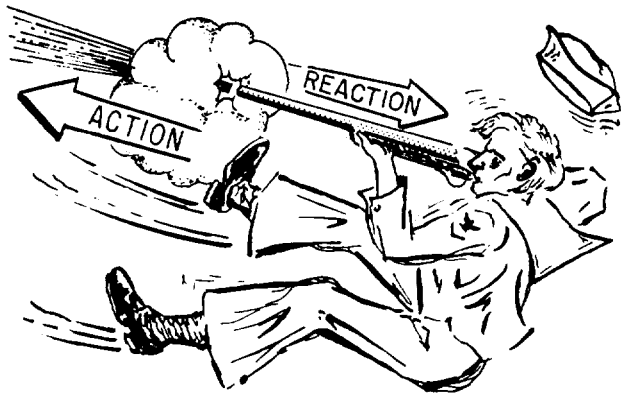

Figure 6-5.—Newton's third law of motion.

cruising range and reliability, but they have a disadvantage when used in antisubmarine warfare. Their low-frequency sounds travel great distances through water, making them easily detected by passive sonar. Steam turbines have been combined with gas turbines in the steam and gas turbine propulsion (COSAG) configuration to reduce low-frequency sound. This configuration requires more personnel to operate and does not have the range of the diesel combinations. Another configuration, the combined gas turbine or gas turbine (COGOG) has also been successful. The British County class destroyers use the 4,500 hp Tyne gas turbine engine for cruising and the 28,000 hp Rolls Royce Olympus engine for high speed.

The U.S. Navy entered the marine gas turbine field with the Asheville class patrol gunboats. These ships have the CODOG configuration, with two diesel engines for cruising, and a General Electric LM 1500 gas turbine for operating at high speed. As a result of the increasing reliability and efficiency of new gas turbine designs, the Navy has now designed and is building cruisers, destroyers, and frigates that are entirely propelled by marine gas turbine engines.

### BASIC ENGINE THEORY

Newton's third law of motion states that for every action there is an equal and opposite reaction. If you have ever fired a shotgun and felt the recoil, you have experienced an example of action-reaction (fig. 6-5). This law of motion is demonstrated in a gas turbine by hot and expanding gases striking the turbine wheel (action) and causing the wheel to rotate (reaction).

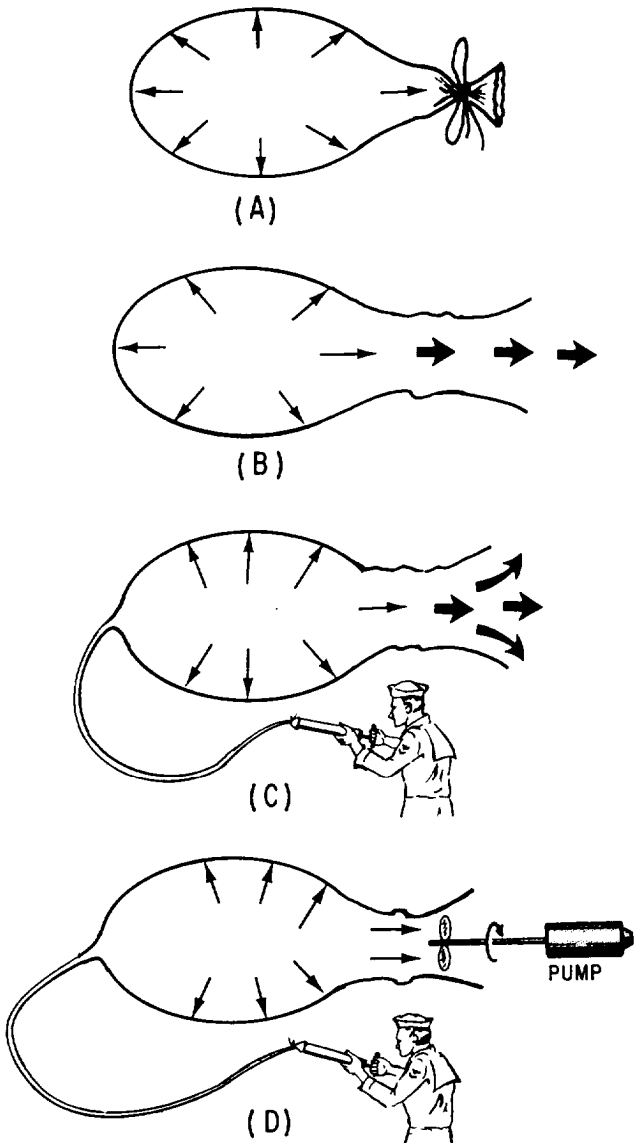

Figure 6-6.—Turbine operating theory.

### OPERATING PRINCIPLES

Figure 6-6 demonstrates the basic principles of gas turbine operation.

A blown-up balloon (fig. 6-6, view A) does nothing until the trapped air is released. The air escaping rearward (fig. 6-6, view B) causes the balloon to move forward (Newton's third law). If we could keep the balloon full of air (fig. 6-6, view C), the balloon would continue to move forward.

If a fan or pinwheel is placed in the air stream (fig. 6-6, view D), the pressure energy and velocity energy will rotate the fan and it can then be used to do work.

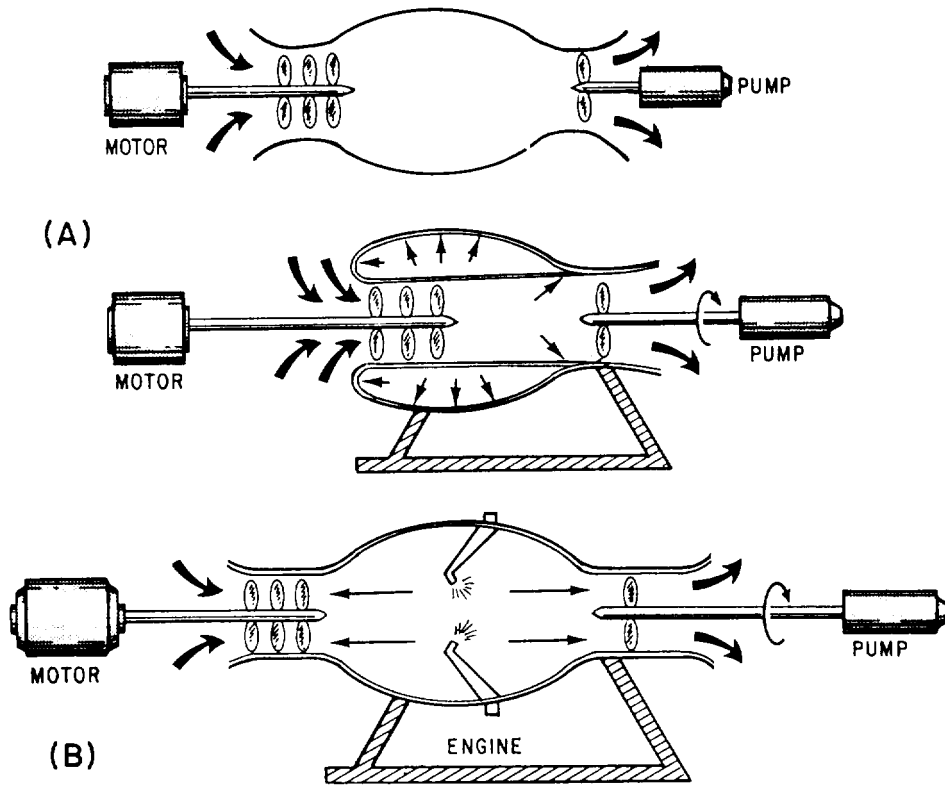

Figure 6-7.—Turbine operating theory.

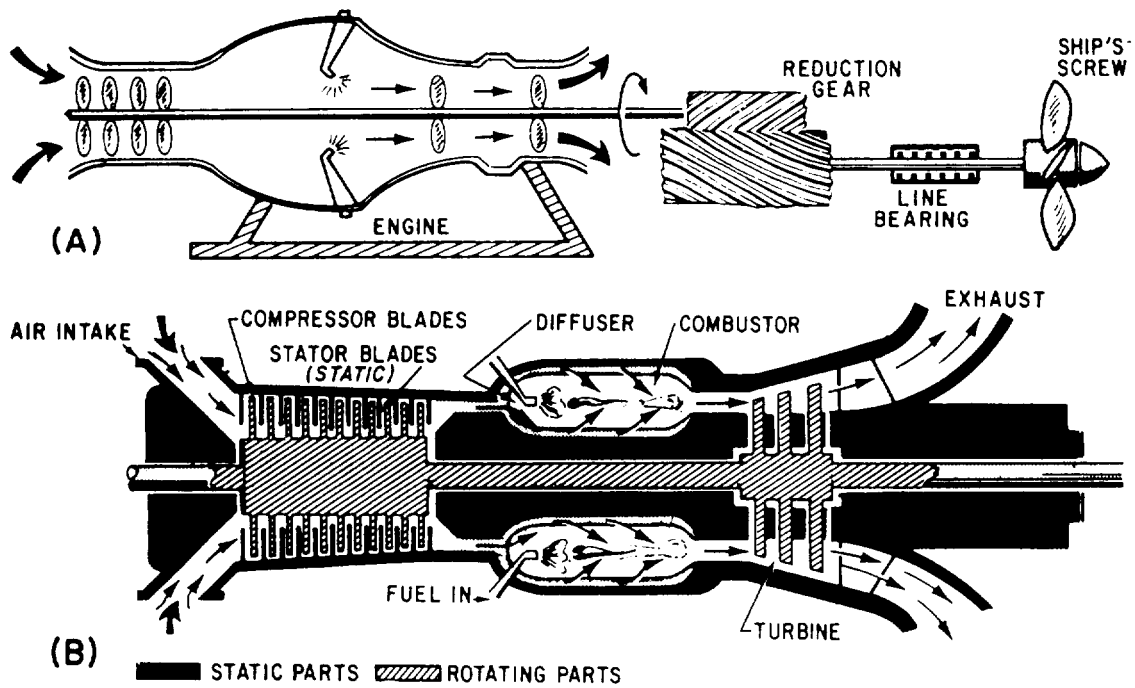

Figure 6-8.—Practical demonstration of turbine operating theory.



By replacing the balloon with a stationary tube or container and filling the tube with air from a fan or series of fans, we can use the discharge air to do work by turning a fan at the rear of the tube (fig. 6-7, view A).

If fuel is added and combustion occurs, we greatly increase both the volume of air and the velocity that propels it over the fan. This increases the horsepower the fan will produce (fig. 6-7, view B). The continuous pressure created by the inlet fan, or compressor, prevents the hot gases from going forward.

Next, if we attach a shaft to the compressor and extend it back to a turbine wheel, we have a simple gas turbine. It can supply power to run its own compressor and still provide enough

power to do useful work, such as to drive a generator or propel a ship (fig. 6-8, view A).

By comparing view A with view B in figure 6-8, you can see that a gas turbine is very similar to our balloon turbine.

### THEORETICAL CYCLES

A cycle is a process that begins with certain conditions, progresses through a series of events, and returns to the original conditions.

As an introduction to gas turbine operation, consider first the reciprocating engine, which operates on the Otto cycle. (fig. 6-9, view A). The Otto cycle consists of four basic events that occur at different times but in the same place,

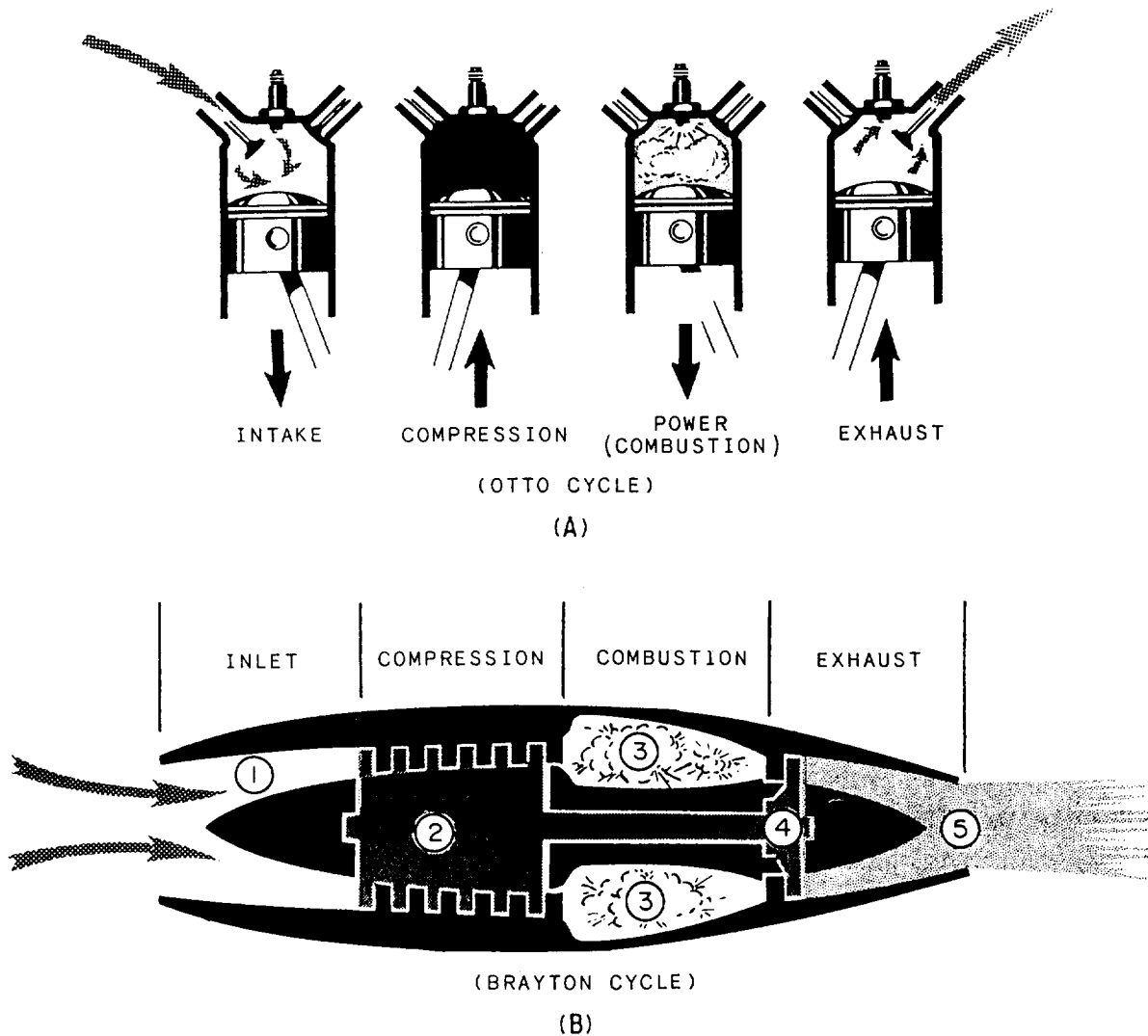

Figure 6-9.—A comparison of reciprocating and gas turbine engine cycles.

inside a cylinder of the engine. The events are (1) intake, where a mixture of air and fuel is drawn into the cylinder; (2) compression, where the mixture is squeezed into a much smaller volume; (3) power (or combustion), where the mixture is burned; and (4) exhaust, where the burned fuel/air mixture is forced from the cylinder. Now consider the gas turbine engine.

The gas turbine engine operates on the Brayton cycle (fig. 6-9, view B). The Brayton cycle consists of the same four events as the Otto cycle. However, all four events occur at the same time, but in different locations within the gas turbine engine.

During the Brayton cycle, air enters the inlet (1) at atmospheric pressure and constant volume. As the air passes through the compressor (2), it increases in pressure and decreases in volume. In the combustor (3), the air mixes with fuel and burns. During combustion, pressure remains constant, but the increased temperature causes a sharp increase in volume. The gases at constant pressure and increased volume enter the turbine (4) and expand through it. As the gases pass through the turbine rotor, the rotor turns kinetic and thermal energy into mechanical energy to do work. The gases are released through the exhaust (5), with a large drop in volume and at constant pressure. The cycle is now completed.

### GAS TURBINE ENGINE TYPES AND CONSTRUCTION

There are two primary means of classifying gas turbine engines: (1) by the type of compressor used and (2) by how the power is used.

#### CENTRIFUGAL COMPRESSOR

The centrifugal compressor draws in air at the center or eye of the impeller and accelerates it around and outward. It consists of an impeller, a diffuser, and a compressor manifold. The diffuser is bolted to the manifold, and often the entire assembly is referred to as the diffuser. For ease of understanding, we will treat each unit separately.

The impeller may be either single entry or dual entry (fig. 6-10). The principal differences between the single entry and dual entry are the size of the impeller and the ducting arrangement. The single-entry impeller (fig. 6-10, view A) permits ducting directly to the inducer vanes, as opposed to the more complicated ducting needed to reach the rear side of the dual-entry type. Although slightly more efficient in receiving air, single-entry impellers must be of greater diameter to provide sufficient air.

Dual-entry impellers (fig. 6-10, view B) are smaller in diameter and rotate at higher speeds to ensure sufficient airflow. Most gas turbines of modern design use the dual-entry compressor to reduce engine diameter. A plenum (an enclosure in which air is at a pressure greater than that outside the enclosure) chamber is also required for dual-entry compressors, since the air must enter the engine at almost right angles to the engine axis. The air must surround the compressor at positive pressure to give positive flow.

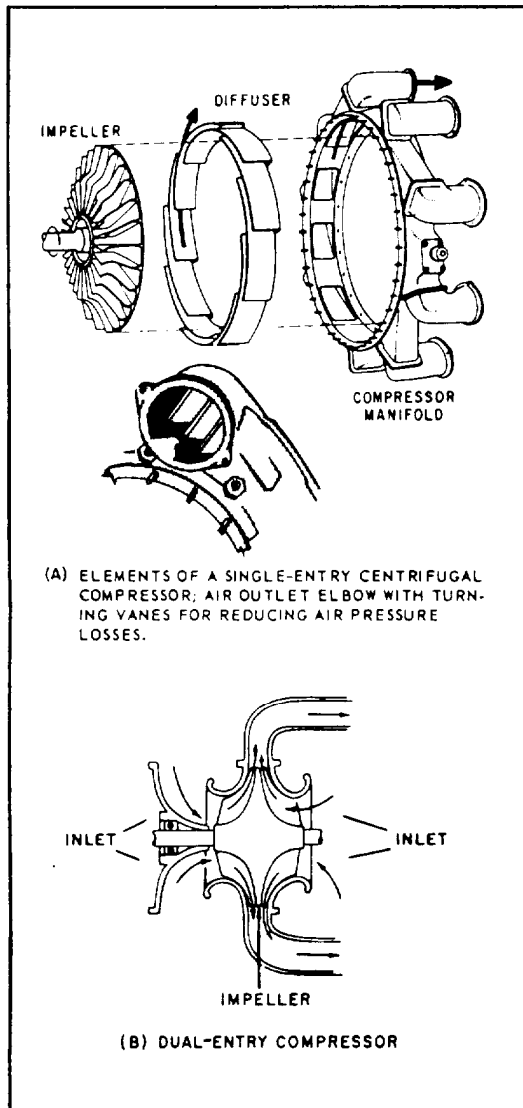

Figure 6-10.—Centrifugal compressor.

The compressor draws in air at the hub of the impeller and accelerates it radially outward by centrifugal force through the impeller. It leaves the impeller at high speed and low pressure and flows through the diffuser (fig. 6-10, view A). The diffuser converts the high-speed, low-pressure air to low-speed, high-pressure air. The compressor manifold diverts the low-speed, high-pressure air from the diffuser into the combustion chambers. In this design, the manifold has one outlet port for each combustion chamber.

The outlet ports are bolted to an outlet elbow on the manifold. The outlet ports ensure that the same amount of air is delivered to each combustion chamber.

The outlet elbows (known by a variety of names) change the airflow from radial to axial flow. The diffusion process is completed after the turn. Each elbow contains from two to four turning vanes that perform the turning process and reduce air pressure losses by providing a smooth turning surface.

### AXIAL-FLOW COMPRESSOR

In the axial-flow engine, the air is compressed while continuing its original direction of flow

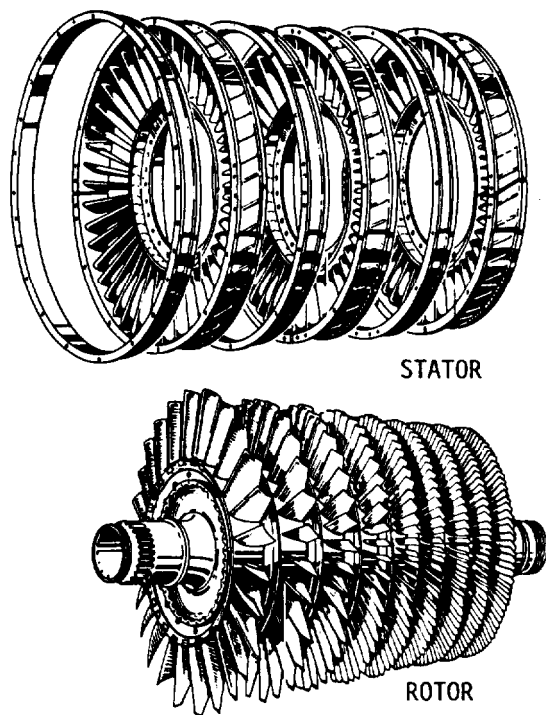

Figure 6-11.—Stator and rotor components of an axial-flow compressor.

parallel to the axis of the compressor rotor. The compressor is located at the very front of the engine. The purpose of the axial compressor is to take in ambient air, increase the speed and pressure, and discharge the air through the diffuser into the combustion chamber.

The two main elements of an axial-flow compressor are the rotor and stator (fig. 6-11). The rotor is the rotating element of the compressor. The stator is the fixed element of the compressor. The rotor and stator are enclosed in the compressor case.

The rotor has fixed blades that force the air rearward much like an aircraft propeller. In front of the first rotor stage are the inlet guide vanes (IGVs). These vanes direct the intake air toward the first set of rotor blades. Directly behind each rotor stage is a stator. The stator directs the air rearward to the next rotor stage (fig. 6-12). Each consecutive pair of rotor and stator blades constitutes a pressure stage.

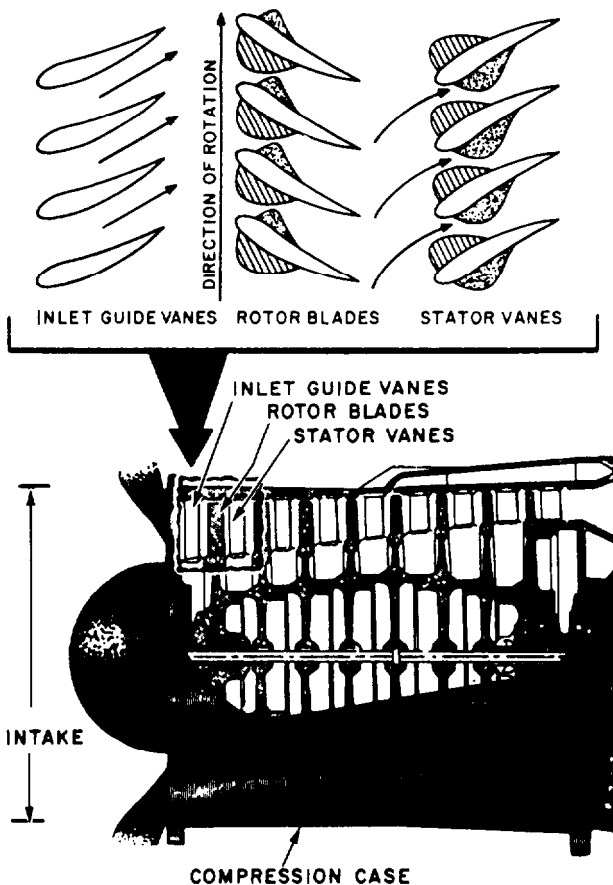

Figure 6-12.—Operating principle of an axial-flow compressor.

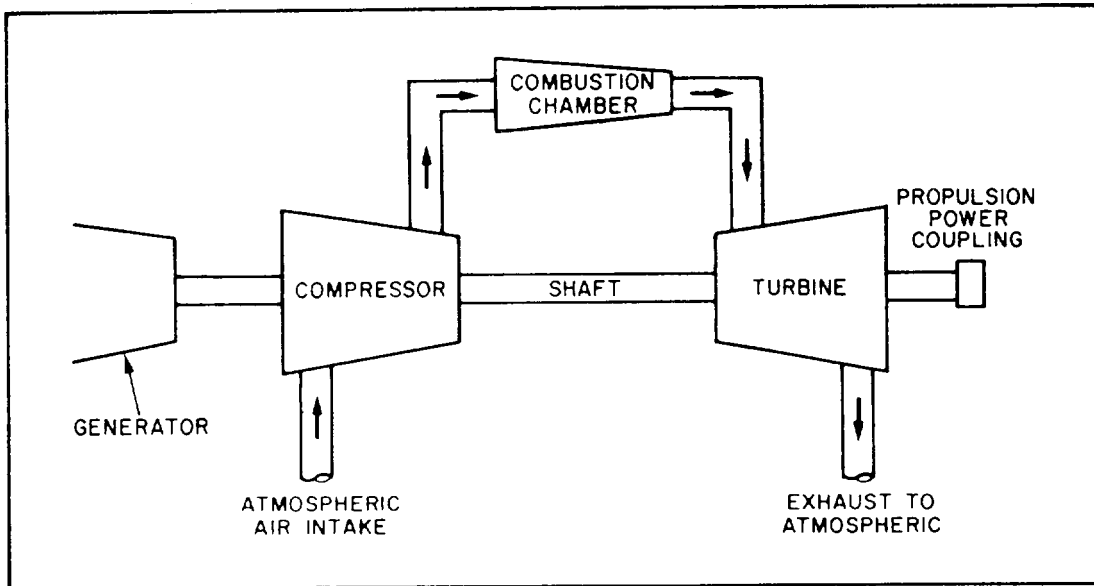

Figure 6-13.—Single-shaft gas turbine.

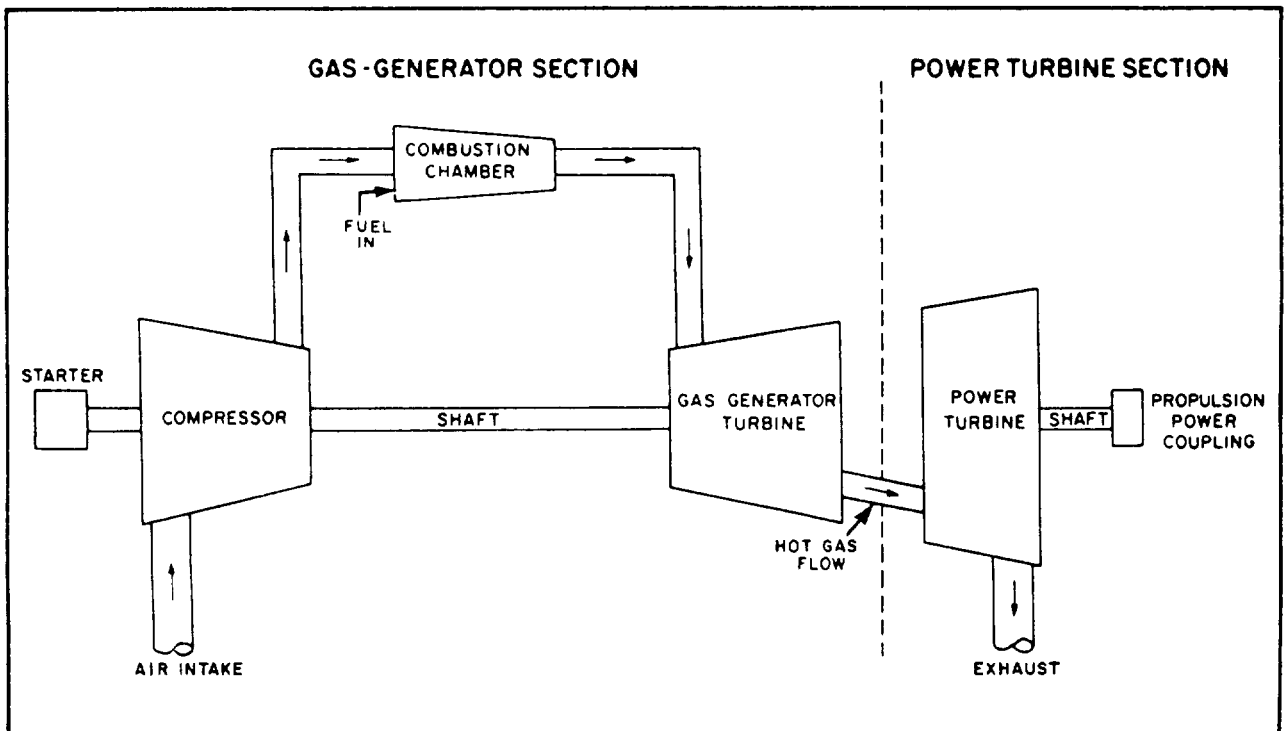

Figure 6-14.—Split-shaft gas turbine.

The action of the rotor increases air compression at each stage and accelerates the air rearward. By virtue of this increased velocity, energy is transferred from the compressor to the air in the form of velocity energy.

The number of stages required is determined by the amount of air and total pressure rise required. The greater the number of stages, the higher the compression ratio. Most present-day engines have 8 to 16 stages.

### CLASSIFICATION BY POWER USAGE

There are basically three types of gas turbines in use. They are the single shaft, split shaft, and twin spool. Of these, the single shaft and split shaft are the most common in naval vessels. We mention the twin-spool type because the U.S. Coast Guard Hamilton class cutters use the twin-spool gas turbine.

In current U.S. Navy service, the single-shaft engine is used primarily for driving ship's service generators. The split-shaft engine is used for main propulsion.

Figure 6-13 is a block diagram of a single-shaft gas turbine. The power output shaft is connected directly to the same turbine rotor that drives the compressor. In most cases, there is a speed reducer or reduction gear between the rotor and the power output shaft. However, there is still a

mechanical connection throughout the entire engine. The arrangement shown is typical for the gas turbine generator sets aboard DD-963 and CG-47 class ships.

In the split-shaft gas turbine (fig. 6-14), there is no mechanical connection between the gas-generator turbine and the power turbine. The power turbine is the component that does the usable work. The gas-generator turbine provides the power to drive the compressor and accessories. With this type of engine, the output speed can be varied by varying the gas generator speed. Also, under certain conditions, the gas generator can run at a reduced rpm and still provide maximum power turbine rpm. This greatly improves fuel economy and also extends the life of the gas-generator turbine. The arrangement shown in figure 6-15 is typical for propulsion gas turbines aboard the DD-963, FFG-7, CG-47, and PHM-1 class ships.

### ENGINE CONSTRUCTION

Recall that a gas turbine engine is composed of four major sections (fig. 6-15): (1) compressor, (2) combustor, (3) turbine, and (4) accessory. We will briefly discuss the construction and function of each of these sections. We will use the LM2500 gas turbine as an example. The LM2500 is a split-shaft gas turbine.

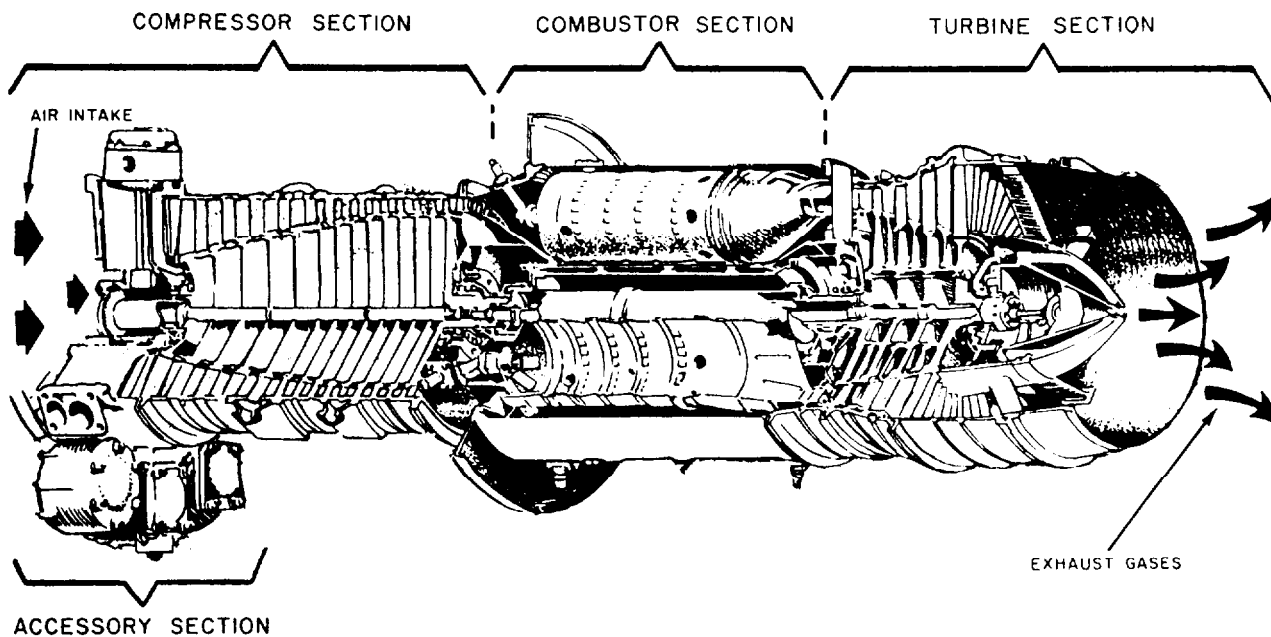

Figure 6-15.—Typical gas turbine.

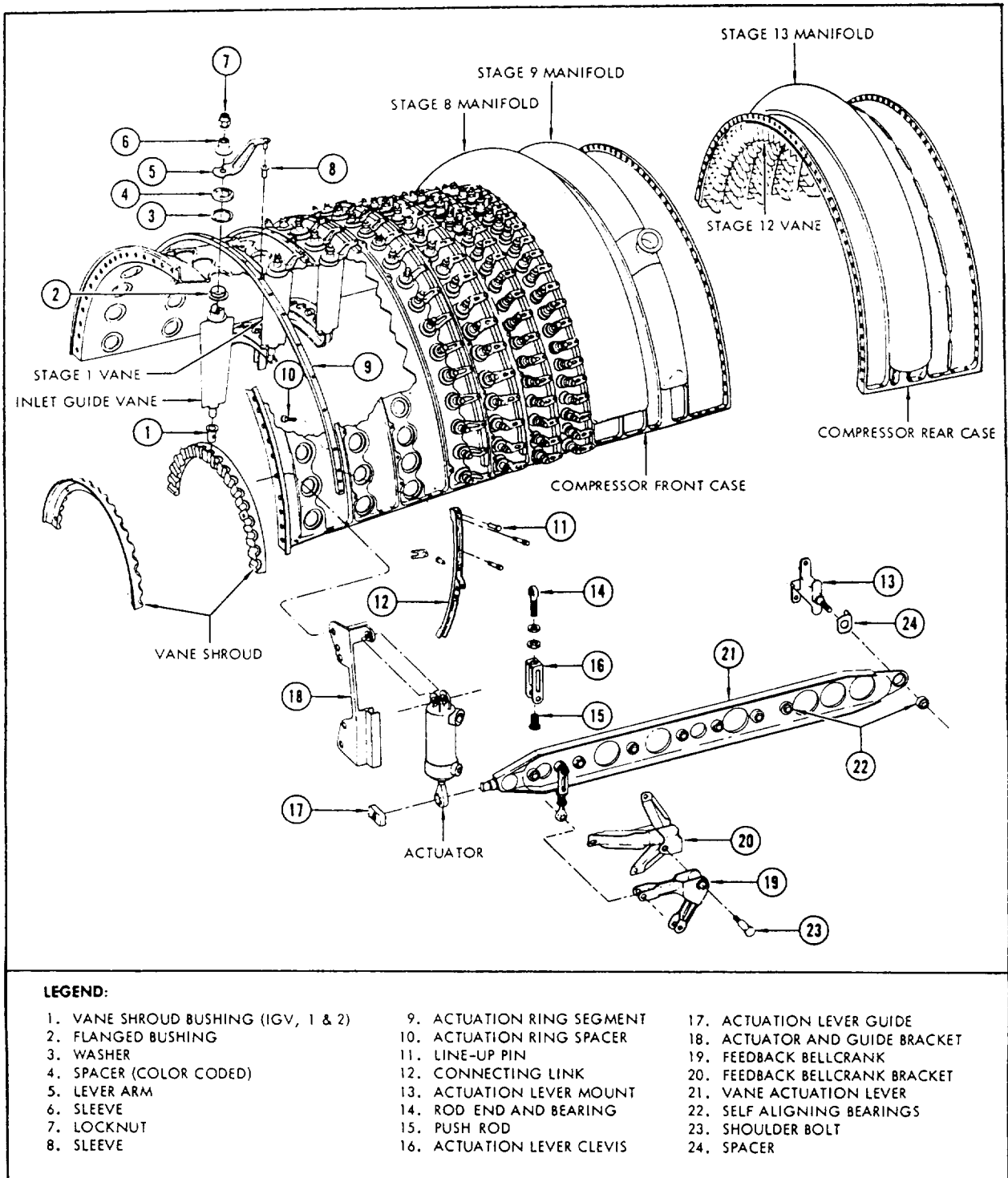

Figure 6-16.—Compressor case, LM2500 engine.

## Compressor

The rotor and stators are enclosed in the compressor case (fig. 6-16). Modern engines use a case that is horizontally divided into upper and lower halves. The halves are normally bolted together with either dowel pins or fitted bolts. These parts ensure proper alignment to each other and in relation to other engine assemblies that bolt to either end of the compressor case.

On some older engines, the case is a one-piece cylinder open on both ends. The one-piece compressor case is simpler to manufacture; however, any repair or detailed inspection of the compressor rotor is impossible. The engine must be removed and taken to a shop where it can be disassembled for repair or inspection of the rotor or stators. On many split-case engines, either the upper or lower case can be removed for maintenance and inspection with the engine in place.

The compressor case is usually made of aluminum or steel. The material used will depend on the engine manufacturer and the accessories attached to the case. The compressor case may have external connections made as part of the case. These connections are normally used to bleed air during starting and acceleration or at low-speed operation.

Preceding the stators and the first stage of the compressor rotor is a row of IGVs. The function of the IGVs varies somewhat, depending on the size of the engine and air-inlet construction. On smaller engines, the air inlet is not totally in line with the first stage of the rotor. The IGVs straighten the airflow and direct it to the first-stage rotor. On large engines, the IGVs can be moved to direct the airflow at the proper angle to reduce drag on the first-stage rotor.

Small and medium engines have stationary stators. On large engines, the pitch of the vanes on several stators can be changed. For example, in the LM2500 engine (fig. 6-16) the first six stators of the 16-stage rotor are variable,

Rotor blades (fig. 6-17) are usually made of stainless or iron-based, super-strength alloys. Methods of attaching the blades in the rotor disk rims vary in different designs, but they are commonly fitted into disks by either bulb (fig. 6-17, view A) or fir-tree (fig. 6-17, view B) type roots. The blades are then locked with grub screws, peening, lockwires, pins, or keys.

The stator vanes project radially toward the rotor axis and fit closely on either side of each stage of the rotor. The stators have two functions.

They receive air from the air inlet duct or from each preceding stage of the rotor and then deliver the air to the next stage or to combustors at a workable velocity and pressure. They also control the direction of air to each rotor stage to obtain the maximum compressor-blade efficiency. The stator vanes are usually made of steel with corrosion- and erosion-resistant qualities. Frequently, the vanes are shrouded by a band of suitable material to simplify the fastening problem. The vanes are welded into the shrouds, and the outer shrouds are secured to the inner wall of the compressor case by retaining screws.

## Combustion Chambers

There are three types of combustion chambers: (1) can type, (2) annular type, and (3) can-annular type. The can-type chamber is used primarily on

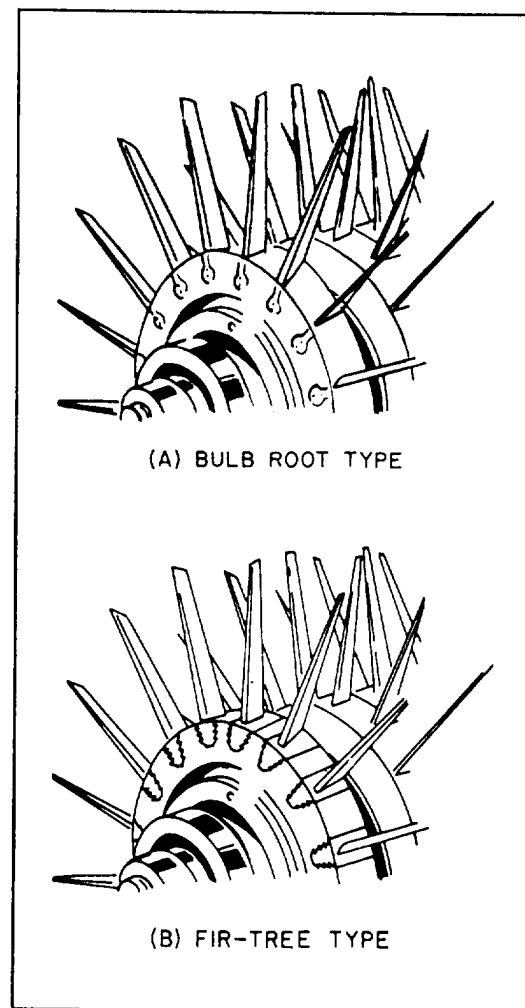

Figure 6-17.—Rotor blades.

engines that have a centrifugal compressor. The annular and can-annular types are used on axial-flow compressors.

The combustion chambers have presented one of the biggest problems in gas turbines. The extreme stresses and temperatures encountered are not experienced in other types of internal-combustion engines. The liners are subjected to temperatures as high as 4000°F in a matter of seconds.

The combustion chamber must operate over a wide range of conditions. It must withstand high rates of burning, have a minimum pressure drop, be light in weight, and have minimum bulk.

The inner and outer liners or shrouds are perforated with many holes and slots throughout their length. Air is admitted through these holes to protect the liner and to cool the gases at the chamber outlet.

The through-flow passages are used in practically all modern engine combustion chambers. In the through-flow path, the gases pass through the combustion section without a change in direction.

The annular combustor liner (fig. 6-18) is usually found on axial-flow engines. It is probably one of the most popular combustion systems in use. The construction consists of a housing and liner.

On large engines, the liner consists of an undivided circular shroud extending all the way around the outside of the turbine shaft housing. A large one-piece combustor case covers the liner and is attached at the turbine section and diffuser section.

The dome of the liner has small slots and holes to admit primary air and to impart a swirling motion for better atomization of fuel. There are also holes in the dome for the fuel nozzles to extend through into the combustion area. The inner and outer liners form the combustion space. The outer liner keeps flame from contacting the combustor case, and the inner liner prevents flame from contacting the turbine shaft housing.

Large holes and slots are located along the liners to (1) admit some cooling air into the

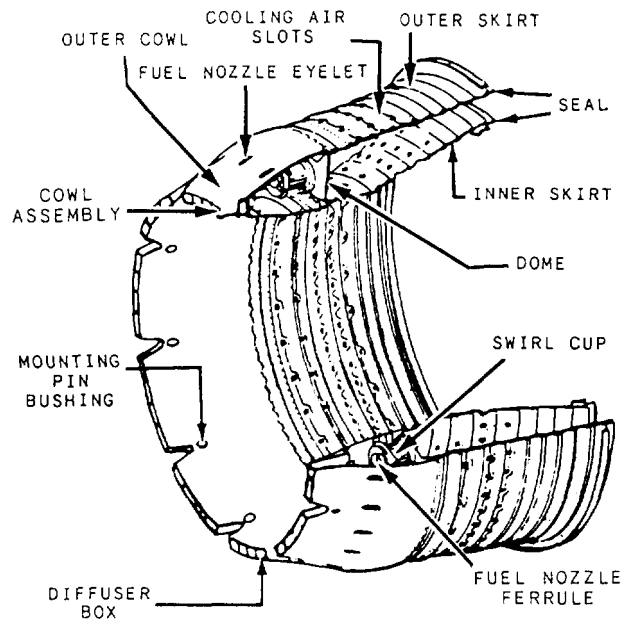

Figure 6-18.—Combustor liner.

combustion space towards the rear of the space to help cool the hot gases to a safe level, (2) center the flame, and (3) admit air for combustion. The gases are cooled enough to prevent warpage of the liners.

The space between the liners and the case and shaft housing forms the path for secondary air. The secondary air provides film cooling of the liners and the combustor case and shaft housing. At the end of the combustion space and just before the first-stage turbine nozzle, the secondary air is mixed with the combustion gases to cool them enough to prevent warping and melting of the turbine section.

The annular-type combustion chamber is a very efficient system that minimizes bulk and can be used most effectively in limited space. There are some disadvantages, however. On some engines, the liners are one-piece and cannot be removed without engine disassembly.

## Turbines

In theory, design, and operating characteristics, the turbines used in gas turbine engines are quite similar to the turbines used in a steam plant. The gas turbine differs from the steam turbine chiefly



in (1) the type of blading material used, (2) the means provided for cooling the turbine shaft bearings, and (3) the lower ratio of blade length to wheel diameter.

The terms *gas-generator turbine* and *power turbine* are used to differentiate between the turbines. The gas-generator turbine powers the gas generator and accessories. The power turbine powers the ship's propeller through the reduction gear and shafting.

The turbine that drives the gas generator is located directly behind the combustion chamber outlet. This turbine consists of two basic elements: the stator or nozzle and the rotor. Part of a stator

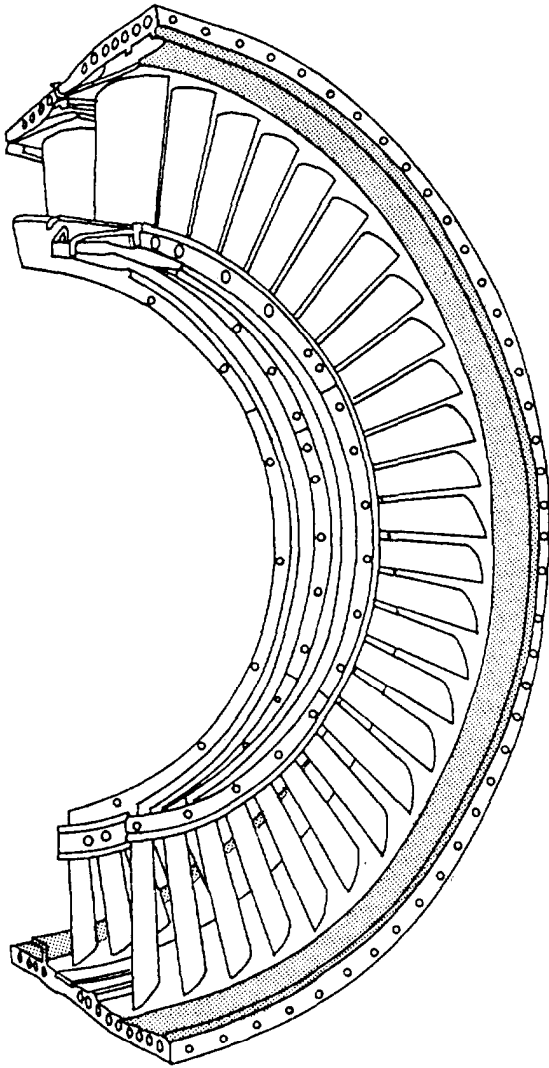

Figure 6-19.—Stator element of turbine assembly.

element is shown in figure 6-19. A rotor element is shown in figure 6-20.

The rotor element of the turbine consists of a shaft and bladed wheel(s). The wheel(s) are attached to the main power transmitting shaft of the gas turbine engine. The jets of combustion gas leaving the vanes of the stator element act upon the turbine blades and cause the turbine wheel to rotate in a speed range of 3,600 to 42,000 rpm, depending upon the type of engine. The high rotational speed imposes severe centrifugal loads on the turbine wheel. At the same time, the high temperature (1050° to 2300 °F) results in a lowering of the strength of the material. Consequently, the engine speed and temperature must be controlled to keep turbine operation within safe limits. The operating life of the turbine blading usually determines the life of the gas turbine engine.

The turbine wheel is a dynamically balanced unit consisting of blades attached to a rotating disk. The disk, in turn, is attached to the rotor shaft of the engine. The high-velocity exhaust gases leaving the turbine nozzle vanes act on the blades of the turbine wheel. This causes the assembly to rotate at a high rate of speed. This turbine rotation, in turn, causes the compressor to rotate.

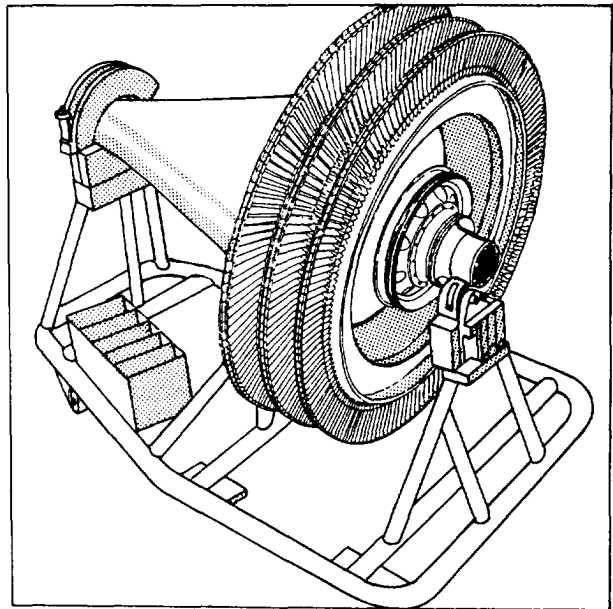

Figure 6-20.—Rotor element of turbine assembly.

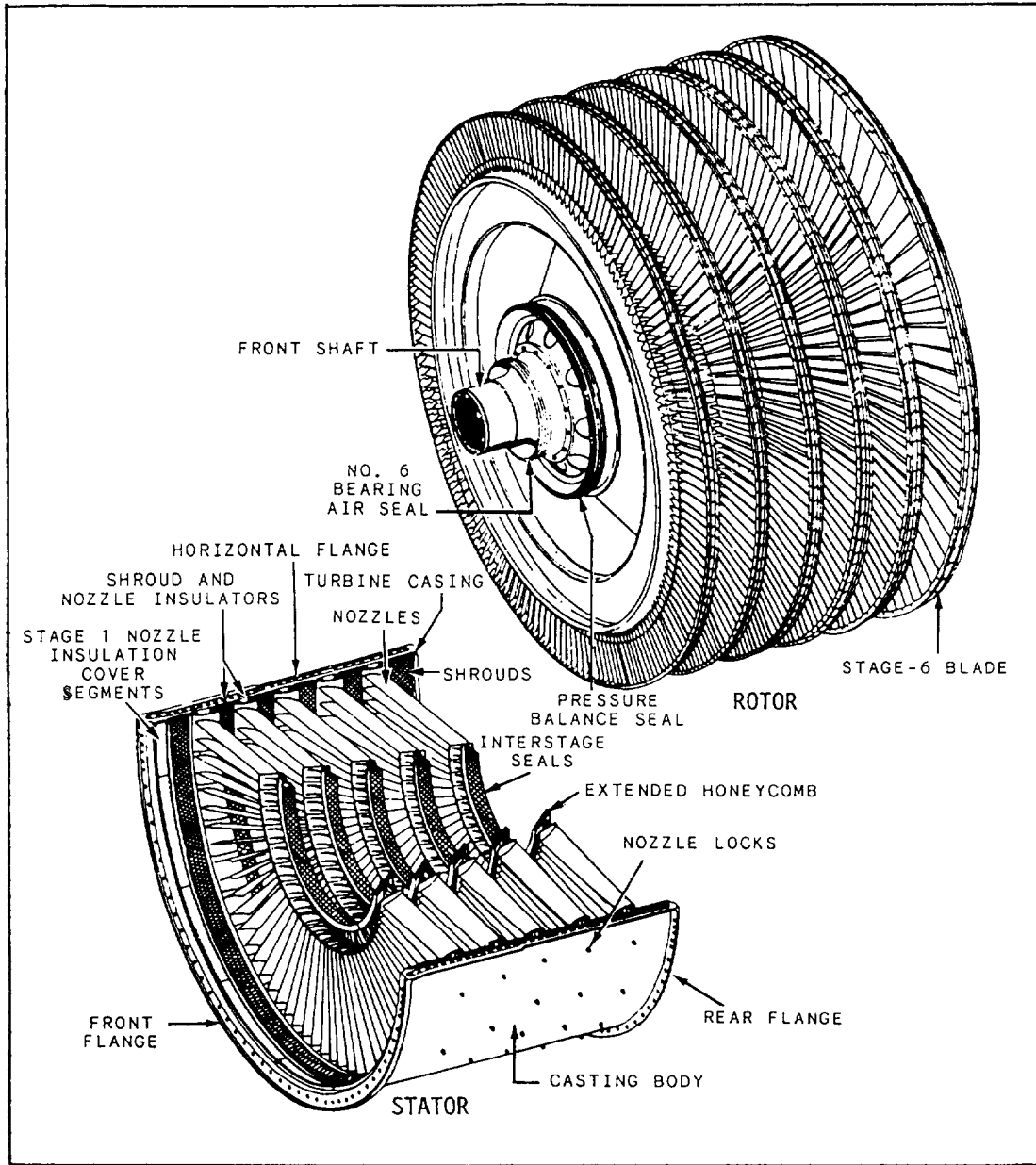

Figure 6-21.—Power turbine.

The power turbine (fig. 6-21) is a multistage unit located behind the gas-generator turbine. There is no mechanical connection between the two turbines. The power turbine is connected to a reduction gear through a clutch mechanism. A controllable reversible-pitch (CRP) propeller is used to change direction of the vessel.

#### Accessories

Because the turbine and the compressor are on the same rotating shaft, a popular misconception

is that the gas turbine engine has only one moving part. This is not so. A gas turbine engine requires a starting device, some kind of control mechanism, and power takeoffs for lube oil and fuel pumps. The accessory drive section (fig. 6-15) of the gas turbine engine takes care of these various accessory functions. The primary purpose of the accessory drive section is to provide space for the mounting of the accessories required for the operation and control of the engine. The accessory drive section also serves as an oil

reservoir and/or sump and houses the accessory drive gears and reduction gears.

The gear train is driven by the engine rotor through an accessory drive shaft gear coupling. The reduction gearing within the case provides suitable drive speeds for each engine accessory or component. The accessory drives are supported by ball bearings assembled in the mounting bores of the accessory case.

Accessories usually provided in the accessory drive section include the fuel control (with its governing device), the high-pressure fuel-oil pump or pumps, the oil sump, the oil pressure and scavenging pump or pumps, the auxiliary fuel pump, and a starter. Additional accessories, which may be included in the accessory drive section or which may be provided elsewhere, include a starting fuel pump, a hydraulic oil pump, a generator, and a tachometer. Most of these accessories are essential for the operation and control of any gas turbine engine. However, the particular combination and arrangement and location of engine-driven accessories depend on

the use for which the gas turbine engine is designed.

The three common locations for the accessory section are on the side of the air inlet housing, under the compressor front frame, or under the compressor rear frame.

## GAS TURBINE OPERATION

Naval engineers are constantly striving to design a more reliable engineering plant that provides quick response and requires fewer personnel to operate it. With advances in engineering technology, the use of solid-state devices and the addition of logic and computer systems, some of these design goals were achieved in the automated central operating system (ACOS).

As shown in figure 6-22, ACOS centralizes the engineering plant with all controls and indicators located at the central control station (CCS). The use of logic and computer systems reduces

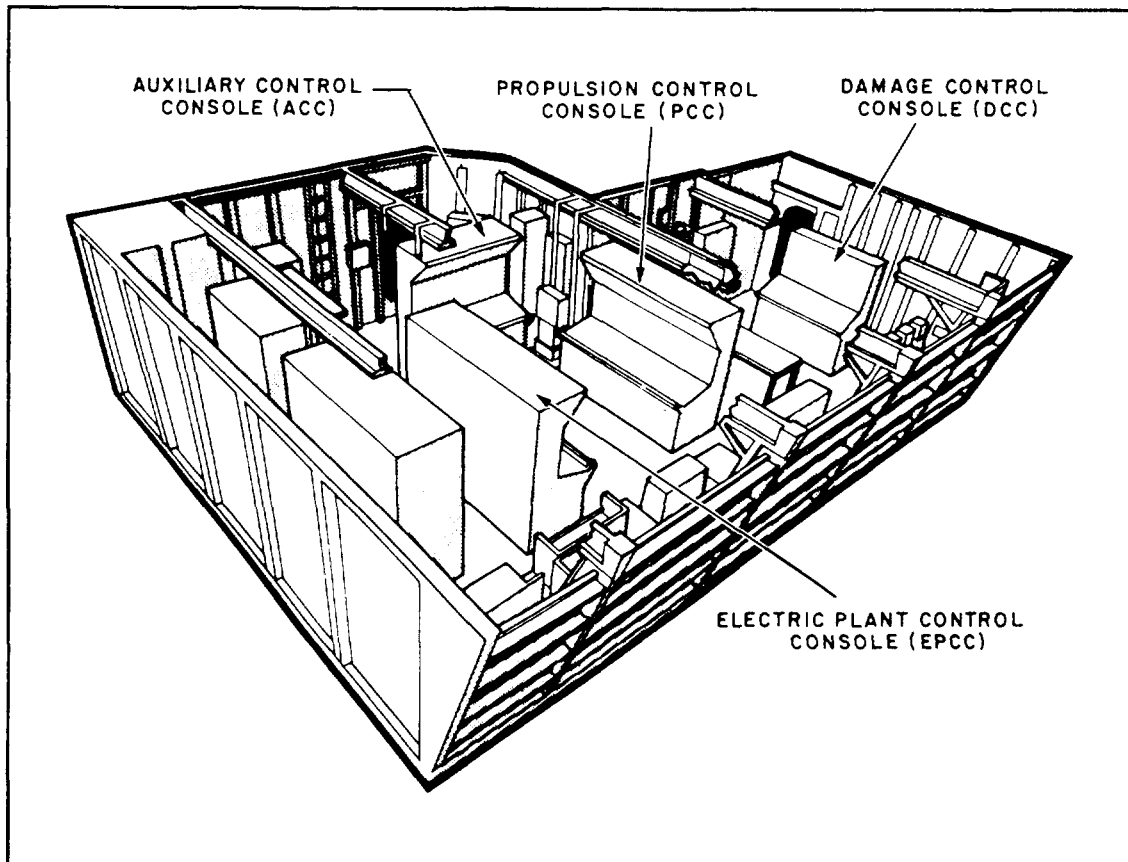

Figure 6-22.—Typical central control station (CCS) for FFG-7 class ships.

the chance of operator error in performing engineering functions. Automatic bell and data loggers reduce the task of hourly readings previously taken by watch standers. Probably the single most important function is the automatic and continuous monitoring of the engineering plant conditions (parameters) and the subsequent automatic alarm if a condition exceeds a set limit.

This section will describe the ACOS that deals with the gas turbine reduction gear and the CRP propeller propulsion system that is currently being installed in new construction ships.

The ACOS provides the means for operating the ship's propulsion plant safely and efficiently. It furnishes the operators with the controls and displays required to start and stop the gas turbine

engines. It also furnishes the operators with the controls necessary to change the ship's speed and direction by changing the gas turbine speed and the pitch of the propeller. These operations are performed at panels or consoles containing the necessary controls and indications for safe operation.

### GENERAL DESCRIPTION

The propulsion plant may be operated from the following three stations:

1. The local control console
2. The central control console
3. The ship control console

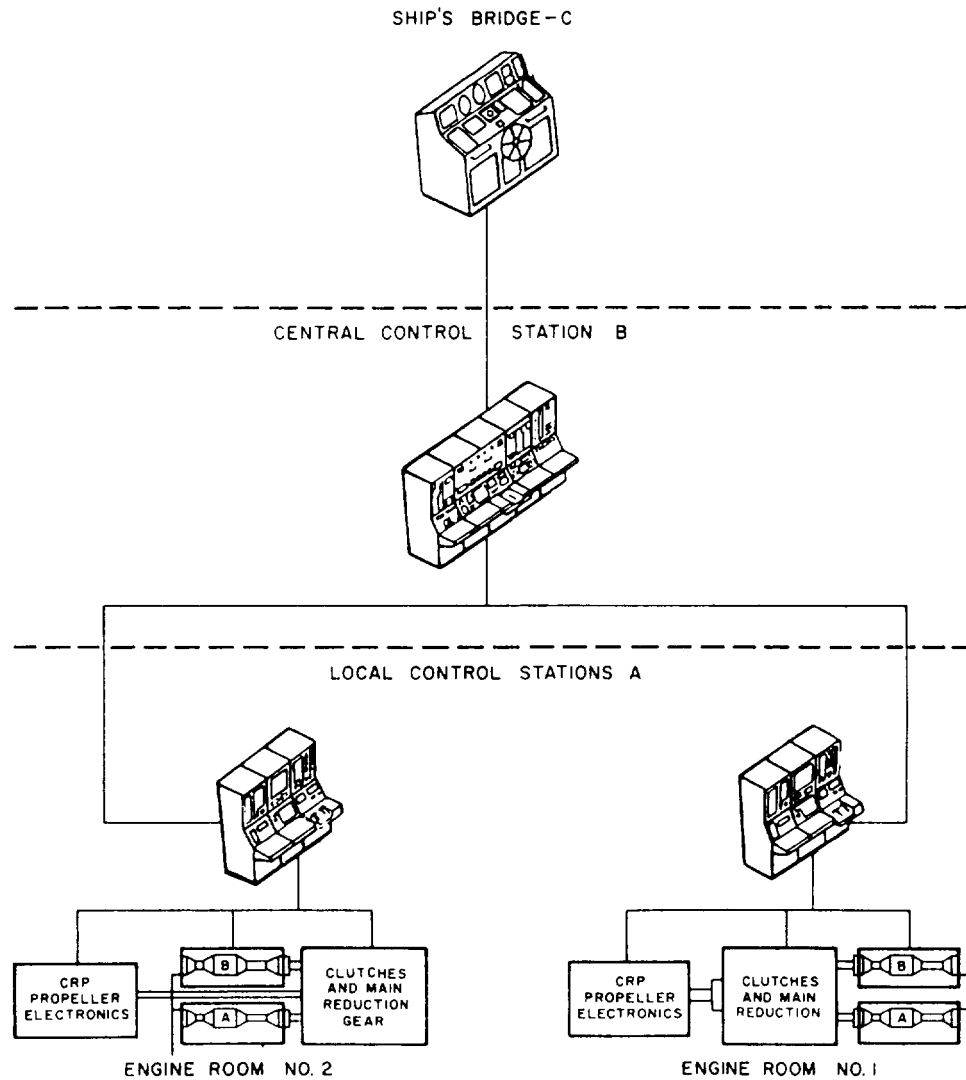

Figure 6-23.—Propulsion control system.

Figure 6-23 is a simplified diagram of the entire propulsion control system.

### LOCAL CONTROL CONSOLE

The local control console is a secondary operating station. It is located in the engine room near the propulsion equipment. It controls and contains the necessary controls and indicators to permit direct local (manual) control of the propulsion equipment. The direct local mode of

control, although still electronic, permits operation of the equipment in a manual mode. The local control console provides facilities for local control of plant starting, normal operation, monitoring, and stopping. Figure 6-24 shows propulsion control stations including the local operating console. The two main controls on this console are the remote throttle control and the pitch control. The remote throttle provides control of the power produced by the gas turbine engine. This control is graduated in percent of gas

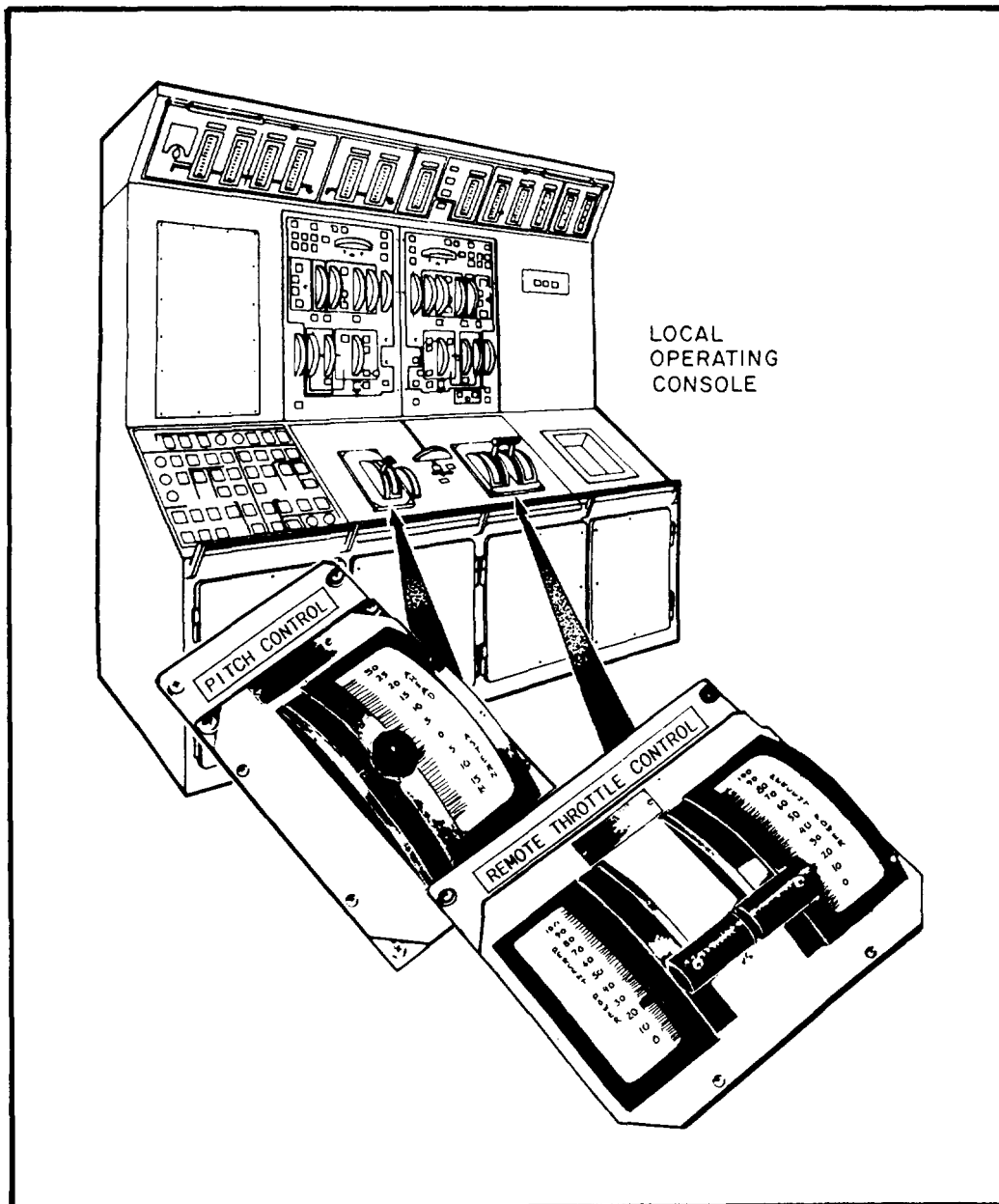

Figure 6-24.—Propulsion control console (local).

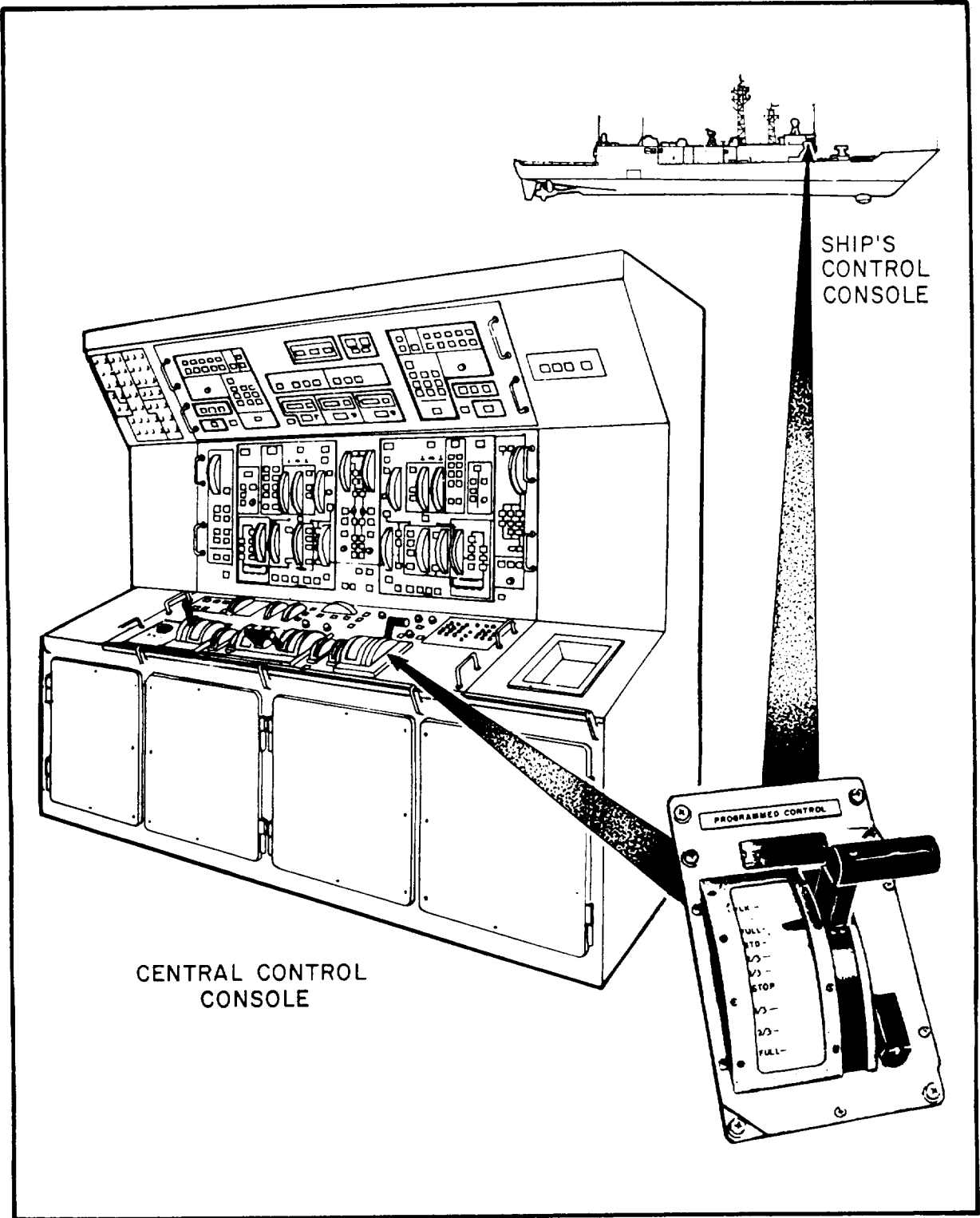

Figure 6-25.—Propulsion control console (central).

turbine engine speed and has control levers similar to an airplane throttle. The pitch lever provides control of the propeller pitch angle. By varying the pitch angle, the ship's speed may be changed. The pitch lever is graduated in feet of pitch either ahead or astern.

### **CENTRAL CONTROL CONSOLE**

The central control console is the primary operating station for the propulsion plant and is located in the CCS. The CCS is the main engineering watch station. This console provides the operator with the necessary controls and displays for starting and stopping the gas turbine engines. Controls on the central control console allow the operator to vary the ship's ahead or astern speed within established design limitations by changing the pitch of the propeller and the speed of the propeller shaft.

The central control console (fig. 6-25) provides two distinctly different methods of controlling the ship's progress through the water. The first method requires the operator to individually adjust three levers on the console. One lever changes the direction and amount of pitch applied at the ship's variable-pitch propeller. Each of the remaining two levers controls the speed of one of the gas turbine engines. This is a duplicate set of controls that are the same as the controls on the local control console.

The second and primary method of operating the ship's propulsion plant involves the use of a single control lever and a special-purpose digital computer contained in the control system. This technique for controlling the engines and the propeller pitch with one control and the digital computer is referred to as single-lever programmed control.

Single-lever programmed control of the ship's propulsion plant can also be maintained from the ship control console (SCC) located on the bridge. However, the lever on the bridge's SCC panel can be operated only after the operator in the CCS relinquishes control.

### **SHIP CONTROL CONSOLE**

This station is located on the ship's bridge. This console has a throttle control, a propulsion plant alarm, and shaft speed and propeller pitch indicators.

### **CONSOLE OPERATING OVERVIEW**

Using modern electronics, computers, and precisely placed sensing equipment, the operator at the central control console can "see" and manipulate the entire propulsion plant. The operator is assisted by sensor-scanning equipment that can check out the plant more thoroughly in a fraction of a second than an engine-room messenger could in 30 minutes. The scanning circuits are wired with information about the operating parameters of all the critical points monitored and will sound off immediately if these are exceeded. The operator's control is extended not only by remote operation of all engine controls but also by wired-in expertise from electronic components that "know" all the right steps and procedures for all normal plant operations as well as most emergency procedures.

There are two directions of information flow in a gas turbine propulsion system. The first is from the sensing and measuring devices on the plant equipment. The second is from the operator and the console to the engine control devices. The first or input flow begins as an electrical signal from a sensor. These signals are "conditioned" so that they can be handled by the digital computer. Some of the signals are displayed on indicators at the operating stations. Most of these indicators are for vital equipment functions.

The control of high-performance engines and other machinery is a complex operation. Automatic central-type operating systems permit a single operator to perform this operation by extending individual ability to sense and to control. As these systems prove their effectiveness and reliability, their use will increase.

### **ADVANTAGES AND DISADVANTAGES OF THE GAS TURBINE PROPULSION SYSTEM**

The gas turbine, when compared to other types of engines, offers many advantages. Its greatest asset is its high power-to-weight ratio. This has made it, in the forms of turboprop or turbojet engines, the preferred engine for aircraft. Compared to the gasoline piston engine, which has the next best power-to-weight characteristics, the gas turbine operates on cheaper and safer fuel. The smoothness of the gas turbine, compared with reciprocating engines, has made it even more desirable in aircraft because less vibration reduces strains on the airframe. In a warship, the lack of

low-frequency vibration in gas turbines makes them preferable to diesel engines because there is less noise for a submarine to pick up at long range. Modern production techniques have made gas turbines economical in terms of horsepower-per-dollar on initial installation, and their increasing reliability makes them a cost-effective alternative to steam turbine or diesel engine installation. In terms of fuel economy, modern marine gas turbines can compete with diesel engines and may be superior to boiler/steam turbine plants when these are operating on distillate fuel.

However, there are some disadvantages to gas turbines. Since they are high-performance engines, many parts are under high stress. Improper maintenance and lack of attention to details of procedure will impair engine performance and may ultimately lead to engine failure. A pencil mark on a compressor turbine blade or a fingerprint in the wrong place can cause failure of the part. The turbine takes in large quantities of air that may contain substances or objects that can harm the engine. Most gas turbine propulsion control systems are complex because several factors have to be controlled, and numerous operating conditions and parameters must be monitored. The control systems must react quickly to turbine operating conditions to avoid casualties to the equipment. Gas turbines produce loud, high-pitched noises that can damage the human ear. In shipboard installations, special

soundproofing is necessary. This adds to the complexity of the installation and makes access for maintenance more difficult.

From a tactical standpoint, there are two major drawbacks to the gas turbine engine. The first is the large amount of exhaust heat produced by the engines. Most current antiship missiles are heat-seekers, and the infrared signature of a gas turbine engine makes it an easy target. Countermeasures, such as exhaust gas cooling and infrared decoys, have been developed to reduce this problem.

The second tactical disadvantage is the requirement for depot maintenance and repair of major casualties. The turbines cannot be repaired in place on the ship and must be removed and replaced by rebuilt engines if anything goes wrong. Here too, design has reduced the problem; an engine change can be accomplished wherever crane service or a Navy tender is available, and the replacement engine can be obtained.

## SUMMARY

This chapter has given you some basic information on gas turbine engines and gas turbine control systems. For a more in-depth look at gas turbines, refer to *Gas Turbine Systems Technician (Mechanical) 3 & 2*, NAVEDTRA 10548-2.



## CHAPTER 7

# INTERNAL-COMBUSTION ENGINES

Internal-combustion engines are used extensively in the Navy. They serve as propulsion units in a variety of ships and boats. Internal-combustion engines are also used as prime movers (drive units) for auxiliary machinery. Because they have pistons that employ a back-and-forth motion, gasoline and diesel engines are also classified as reciprocating engines.

This chapter provides you with the general construction features and operating principles of various types of internal-combustion engines. After reading this chapter, you will have a basic understanding of the components that make up an internal-combustion engine and how these components work together to develop power.

### RECIPROCATING ENGINES

The internal-combustion engines (diesel and gasoline) are machines that convert heat energy into mechanical energy. The transformation of heat energy to mechanical energy by the engine is based on a fundamental law of physics. Gas will expand when heat is applied. The law also states that when a gas is compressed, the temperature of the gas will increase. If the gas is confined with no outlet for expansion, the pressure of the gas will be increased when heat is applied. In the internal-combustion engine, the burning of a fuel within a closed cylinder results in an expansion of gases. The pressure created on top of a piston by the expanding gases causes it to move.

The back-and-forth motion of the pistons in an engine is known as reciprocating motion. This reciprocating motion (straight-line motion) must be changed to rotary motion (turning motion) to perform a useful function, such as propelling a boat or ship through the water or driving a generator to provide electricity. A crankshaft and a connecting rod change this reciprocating motion to rotary motion (fig. 7-1).

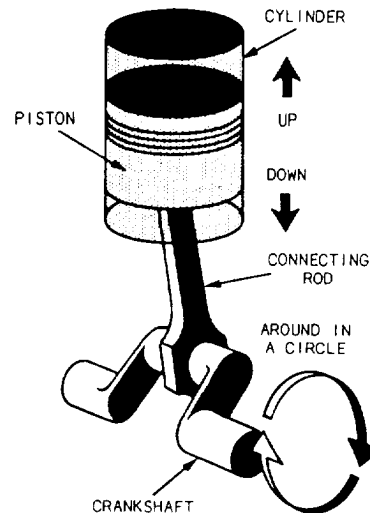

Figure 7-1.—Cylinder, piston, connecting rod, and crankshaft for one cylinder of an engine.

All internal-combustion engines are basically the same. They all rely on three things—air, fuel, and ignition.

Fuel contains potential energy for operating the engine; air contains the oxygen necessary for combustion; and ignition starts combustion. All are fundamental, and an engine will not operate without all of them. Any discussion of engines must be based on these three factors and the steps and mechanisms involved in delivering them to the combustion chamber at the proper time.

### GASOLINE VERSUS DIESEL ENGINES

There are two main differences between gasoline and diesel engines. They are the methods of getting the fuel into the cylinders and of igniting the fuel-air mixtures. In the gasoline engine, the air and gasoline are mixed together outside the combustion chamber. The mixture

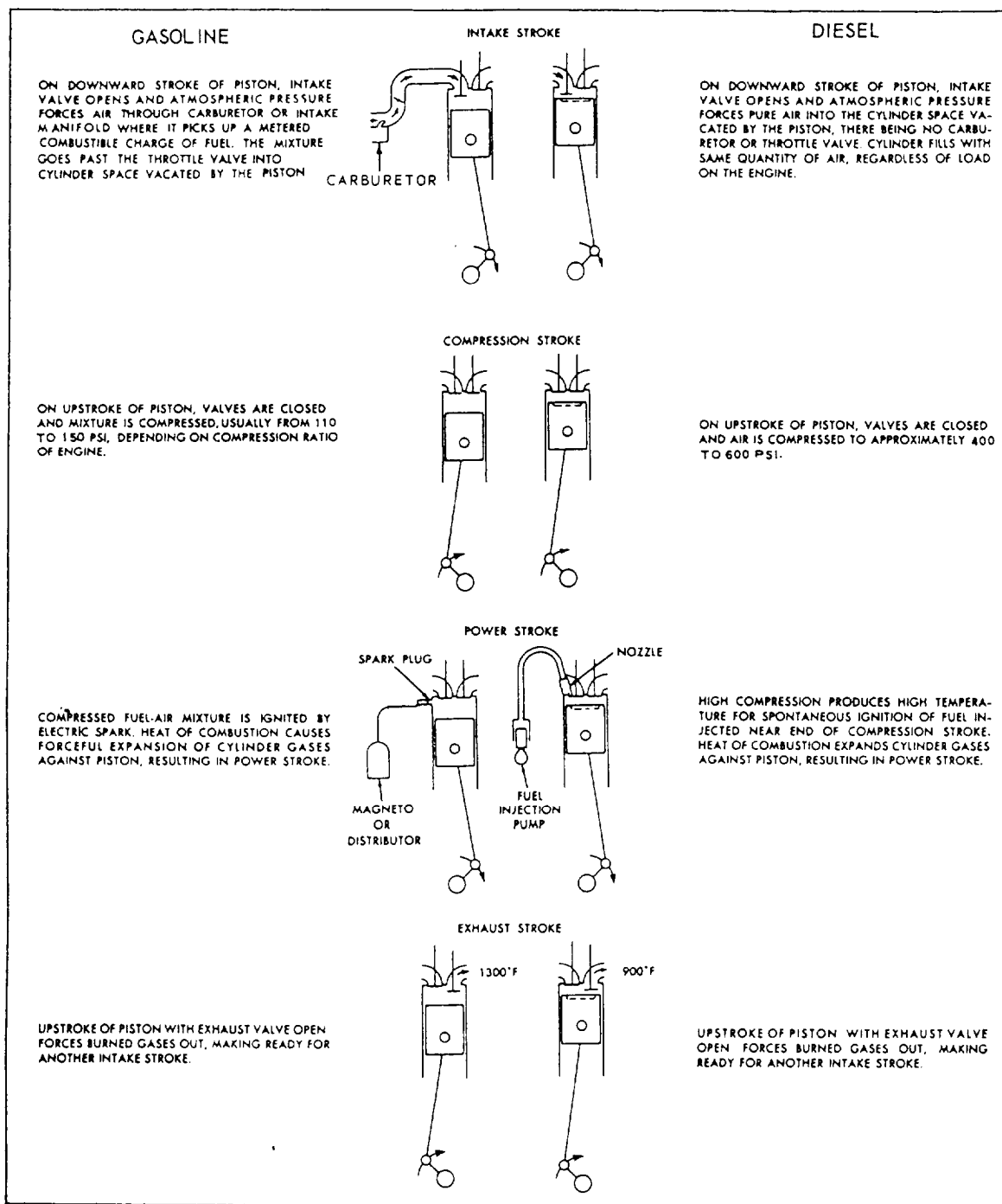

Figure 7-2.—Comparison of events in diesel and gasoline four-cycle engines.

then passes through the intake manifold, where it starts to vaporize. Then the mixture enters the cylinder through the intake valve. Here it is completely vaporized by the heat of compression as the piston moves upward on the compression stroke. When the piston is near the top of its stroke (top dead center or TDC), the mixture is ignited by a spark from the spark plug.

The diesel engine uses neither spark plugs nor a carburetor. On the intake stroke, only fresh air is drawn into the cylinder through the intake valve and manifold. On the compression stroke, the air is compressed and the temperature in the cylinder rises to a point between 700 °F and 1200 °F. At the proper time, the diesel fuel is injected into the cylinder by a fuel injection system. When the fuel

enters the cylinder, it ignites. Figure 7-2 shows the comparison of the four strokes of four-cycle diesel and gasoline engines.

The speed of a diesel or gasoline engine is controlled by the amount of fuel-air mixture that is burned in the cylinders. The primary difference is the method in which the fuel and air enter the combustion chamber. In a diesel engine, the fuel is injected directly into the combustion chamber, where it mixes with air. In a gasoline engine, the fuel and air are mixed in the intake manifold and then drawn into the combustion chamber.

Mechanically, the diesel engine is similar to the gasoline engine. The intake, compression, power, and exhaust strokes occur in the same order. The arrangement of the pistons, connecting rods, crankshaft, and engine valves are also the same.

### DEVELOPMENT OF POWER

The power of an internal-combustion engine comes from the burning of a mixture of fuel and air in a small, enclosed space. When this mixture burns, it expands greatly. The push or pressure created is used to move the piston. The piston then rotates the crankshaft. The rotating crankshaft is then used to perform the desired work.

Since the same actions occur in all cylinders of an engine, we will discuss only one cylinder and its related parts. The four major parts consist of a cylinder, piston, crankshaft, and connecting rod (fig. 7-1).

First we must have a cylinder that is closed at one end. The cylinder is stationary within the engine block.

Inside this cylinder is the piston (a movable metal plug) that fits snugly into the cylinder but can still slide up and down easily. Movement of the piston is caused by the burning fuel-air mixture in the cylinder.

You have already learned that the back-and-forth movement of the piston is called reciprocating motion, which must be changed to rotary motion. This change is accomplished by a throw on the crankshaft and a connecting rod that connects the piston and the crank throw.

The number of piston strokes occurring during any one series of operations (cycles) is limited to either two or four, depending on the design of the engine.

When the piston of the engine slides downward because of the pressure of the expanding gases in the cylinder, the upper end of the

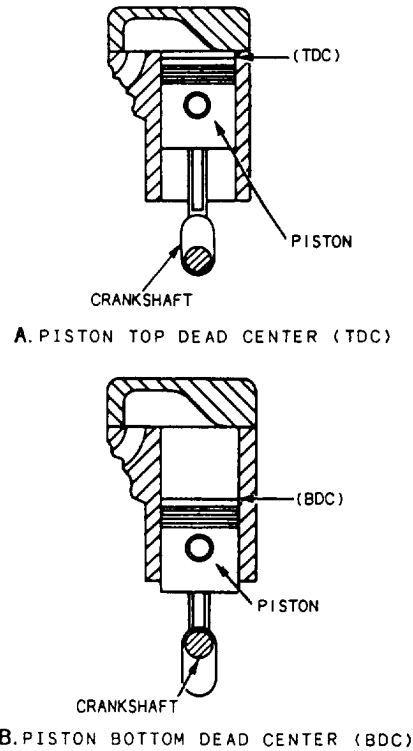

Figure 7-3.—Piston stroke.

connecting rod moves downward with the piston in a straight line. The lower end of the connecting rod moves down and in a circular motion at the same time. This moves the crank throw and, in turn, rotates the shaft. This rotation is the desired result. So remember, the crankshaft and connecting rod combination is a mechanism for the purpose of changing back-and-forth (reciprocating) motion to circular (rotary) motion.

### BASIC ENGINE STROKES

Each movement of the piston from top to bottom or from bottom to top is called a stroke. The piston takes two strokes (an upstroke and a downstroke) as the crankshaft makes one complete revolution. When the piston is at the top of a stroke (fig. 7-3, view A), it is said to be at top dead center (TDC). When the piston is at the bottom of a stroke (fig. 7-3, view B), it is said to be at bottom dead center (BDC).

In the basic engine you have studied so far, we have not considered provisions for getting the fuel-air mixture into the cylinder or burned gases out of the cylinder. There are two openings in the enclosed end of a cylinder. One of the openings,

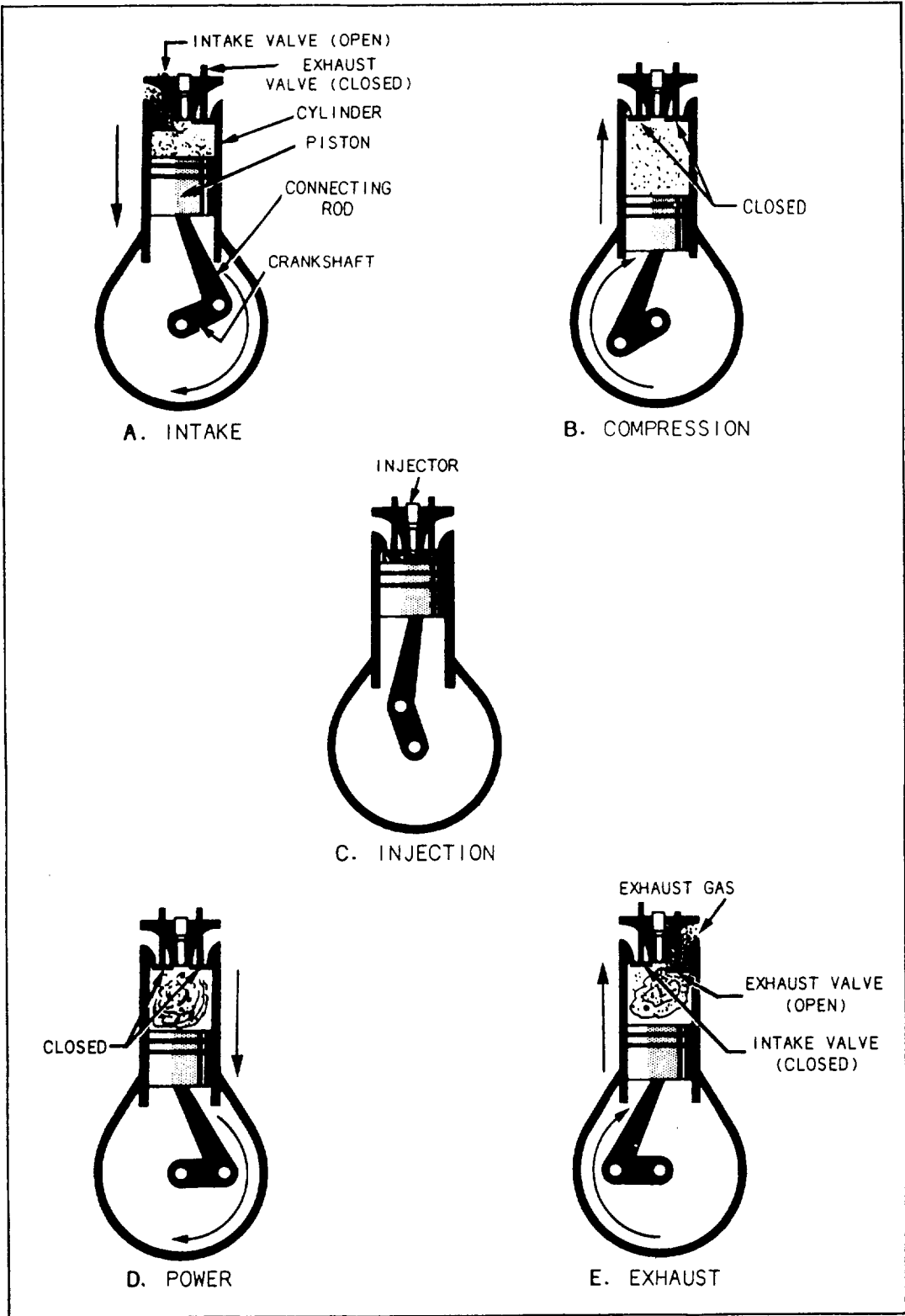

Figure 7-4.—Four-stroke diesel engine.

or ports, permits an intake of air, or an intake of a mixture of fuel and air, into the combustion area of the cylinder (intake valve). The other opening, or port, permits the burned gases to escape from the cylinder (exhaust valve). The two ports have valves in them. These valves close off either one or the other of the ports, or both of them, during various stages of engine operation. The camshaft (a shaft with a number of cam lobes along its length) opens the valves and holds them open for short periods during the piston stroke. The camshaft is driven by the crankshaft through timing gears or by a timing chain. On a four-stroke engine, the camshaft turns at one-half crankshaft speed. This permits each valve to open and close once for every two turns of the crankshaft.

The following sections give a simplified explanation of the action that takes place within the engine cylinder. For the purpose of explanation, we will show the action of a four-stroke diesel engine. This type of engine is referred to as a four-stroke engine because it requires four complete piston strokes to complete one cycle. These strokes are known as the intake stroke, the compression stroke, the power stroke, and the exhaust stroke.

In a four-stroke engine, each piston goes through four strokes, and the crankshaft makes two revolutions to complete one cycle. Each piston delivers power during one stroke in four, or each piston makes one power stroke for each two revolutions of the crankshaft.

We will take one cylinder and trace its operation through the four strokes that make up a cycle (fig. 7-4). The engine parts shown in this figure include a cylinder, a crankshaft, a piston connecting rod, and the intake and exhaust valves. The valve-operating mechanism and the fuel system have been omitted.

During the intake stroke shown in view A, the intake valve is open and the exhaust valve is closed. The piston is moving downward and drawing a charge of air into the cylinder through the intake valve.

When the crankshaft has rotated to the position shown in view B, the piston moves upward

to almost the top of the cylinder. Both the intake and exhaust valves are closed during this stroke. The air that entered the cylinder during the intake stroke is compressed into the small space above the piston. This is called the compression stroke.

The high pressure, which results from the compression stroke, raises the temperature of the air far above the ignition point of the fuel. When the piston nears the top of the compression stroke, a charge of fuel is forced into the cylinder through the injector, as shown in view C. The air, which has been heated by compression, ignites the fuel.

**NOTE:** The injection portion of a cycle is not considered a stroke.

During the power stroke (view D), the intake and exhaust valves are both closed. The increase in temperature resulting from the burning fuel greatly increases the pressure on top of the piston. This increased pressure forces the piston downward and rotates the crankshaft. This is the only stroke in which power is furnished to the crankshaft.

During the exhaust stroke (view E), the exhaust valve is open and the intake valve remains closed. The piston moves upward, forcing the burned gases out of the combustion chamber through the exhaust valve. This stroke, which completes the cycle, is followed immediately by the intake stroke of the next cycle, and the sequence of events continues.

The four-stroke gasoline engine operates on the same mechanical, or operational, cycle as the diesel engine. In the gasoline engine, the fuel and air are mixed in the intake manifold; and the mixture is drawn into the cylinders through the intake valve. The fuel-air mixture is ignited near the top of the compression stroke by an electric spark that passes between the terminals of the spark plug.

Two-stroke diesel engines are widely used by the Navy. Every second stroke of a two-stroke cycle engine is a power stroke. The strokes between are compression strokes. The intake and exhaust functions take place rapidly near the bottom of each power stroke. With this arrangement, there is one power stroke for each

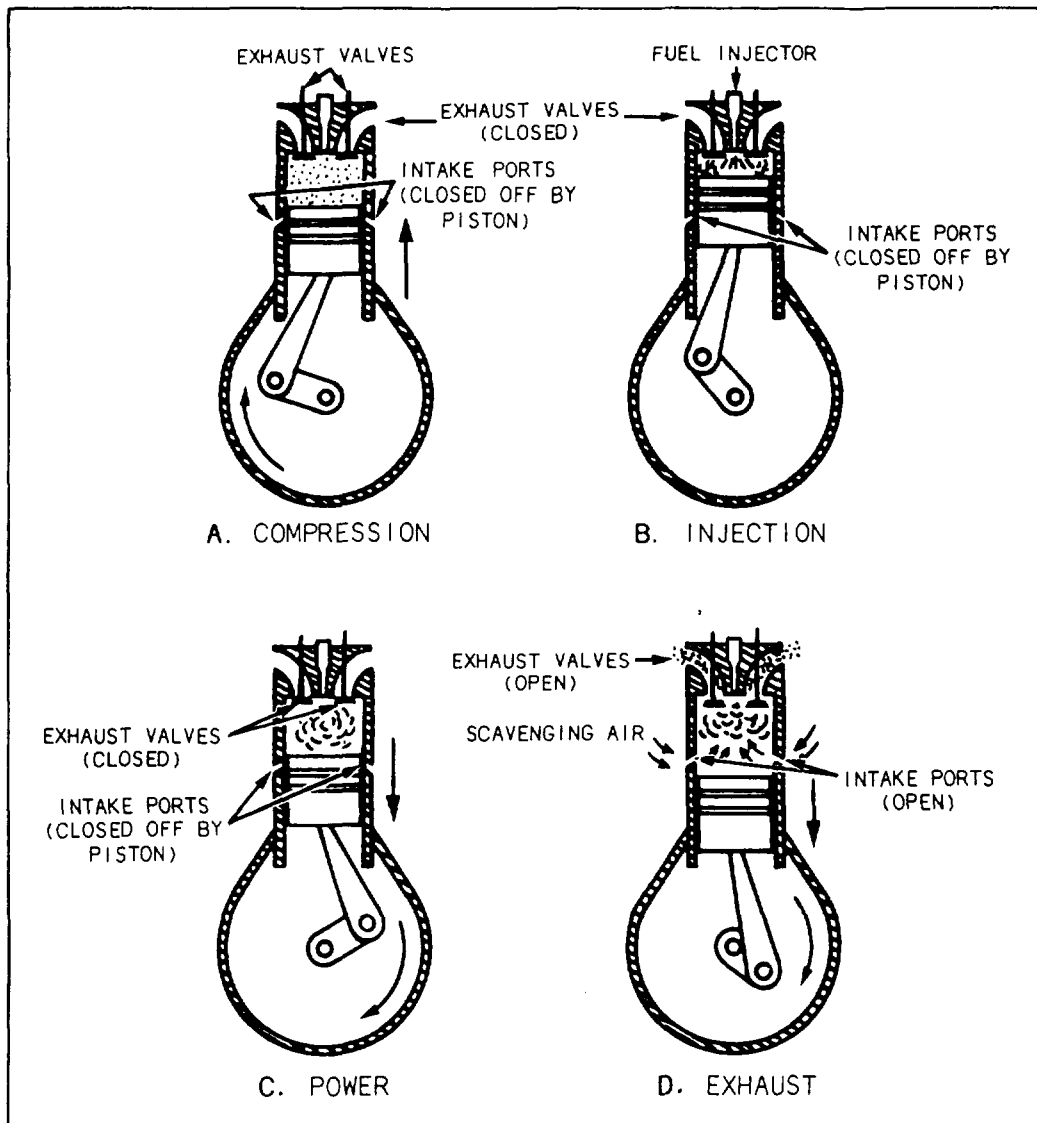

Figure 7-5.—Two-stroke diesel engine.

revolution of the crankshaft, or twice as many as in a four-stroke cycle engine.

**NOTE:** A two-stroke engine does not have intake valves. It has intake ports (fig. 7-5).

The steps in the operation of a two-stroke diesel engine are shown in figure 7-5. In view A, the piston is moving upward on the compression stroke. The exhaust valve and the intake ports are closed, and the piston is compressing the air trapped in the combustion chamber. At the top of the stroke, with the piston in the position shown in view B, fuel is injected (sprayed) into the cylinder and ignited by the hot compressed air.

In view C, the piston is moving downward on the power stroke: The exhaust valves are still closed; and the increased pressure, resulting from the burning fuel, forces the piston downward and rotates the crankshaft.

As the piston nears the bottom of the power stroke (view D), the exhaust valves open and the piston continues downward to uncover the intake ports. Air is delivered under pressure by a blower for two-stroke diesel engines. In a two-stroke gasoline engine, air comes from the crankcase through the intake ports; and the burned gases are carried out through the exhaust valve. This operation (referred to as scavenging air) takes place almost instantly and corresponds to

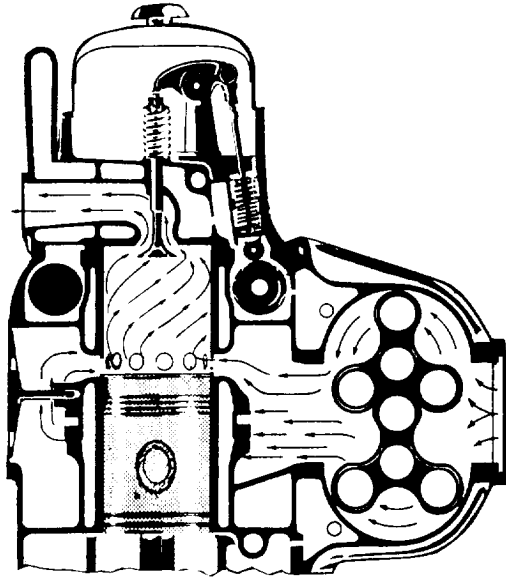

Figure 7-6.—A two-stroke diesel engine cylinder with the piston at the bottom of the power stroke.

the intake and exhaust strokes of the four-stroke cycle.

You might expect a two-stroke engine to develop twice as much power as a four-stroke engine of the same size and to operate at the same speed. However, this is not true. With two-stroke diesel engines, some of the power is used to drive a blower (fig. 7-6) that forces the air charge into the cylinder under pressure. Also, the burned gases are not completely cleared from the cylinder, reducing combustion efficiency. Additionally, because of the much shorter period the intake ports are open (as compared to the period the intake valve in a four-stroke cycle is open), a smaller amount of air is admitted. Therefore, with less air being mixed with the fuel, less power-per-power stroke is produced. Nevertheless, two-stroke diesel engines give excellent service.

### VALVE MECHANISM

The valve mechanism of a two-stroke diesel cylinder head is shown in figure 7-7. This cylinder head has two exhaust valves that are opened at the same time by the action of a single cam. They make a tight fit in the exhaust openings (ports) in the cylinder head and are held in the closed position by the compression of the valve springs. The rocker arm and bridge transmit the reciprocating motions of the cam roller to the valves.

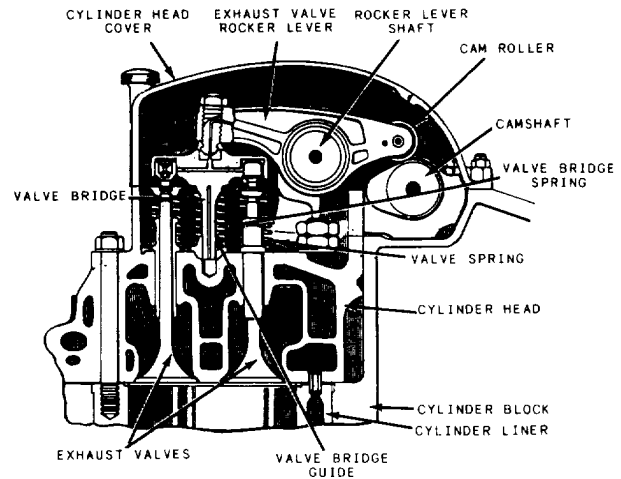

A. EXHAUST CLOSED

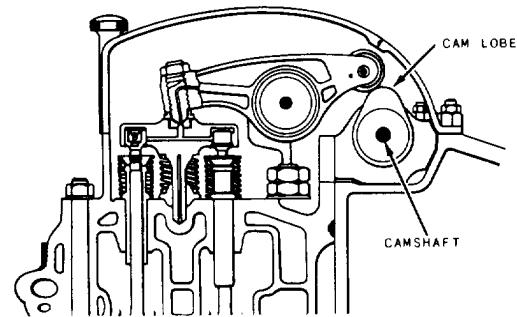

B. EXHAUST OPEN

Figure 7-7.—A two-stroke diesel cylinder head, showing the valve-operating mechanism.

In figure 7-7, view A, the cam roller is riding on the base circle of the cam, and the valves are closed. As the camshaft rotates, the cam lobe or nose rides under the roller and raises it to the position shown in view B. When the roller is lifted, the arm rotates around the rocker shaft; and the opposite end of the arm is lowered. This action pushes the bridge and valves down against the pressure of the valve springs and opens the valve passages.

On some types of engines, the camshaft is located near the crankshaft. In these designs, the action of the cam roller is transmitted to the rocker arm by a pushrod.

The camshaft must be timed with the crankshaft so that the lobes will open the valves in each cylinder at the correct instant in the operating cycle. In the two-stroke engine, the camshaft rotates at the same speed as the crankshaft.

The four-stroke engine has an intake valve and an exhaust valve in every cylinder. Each valve is

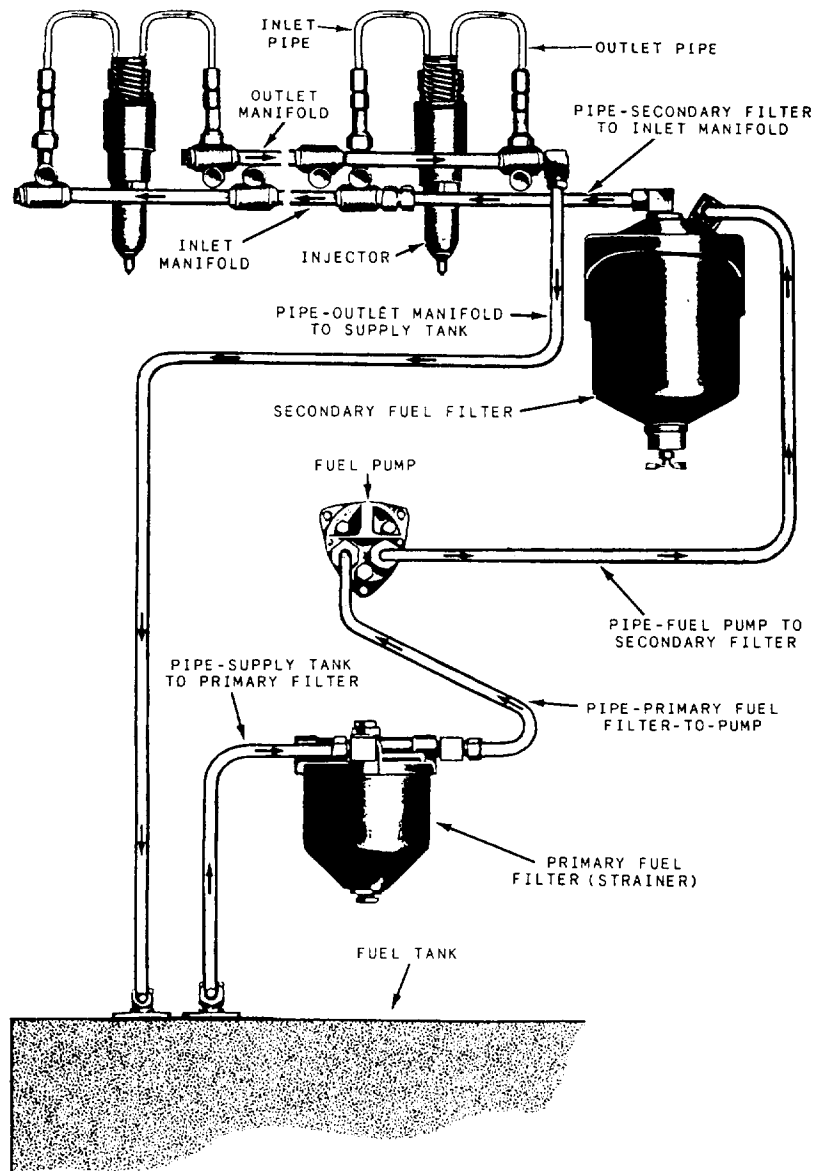

Figure 7-8.—The fuel supply system of a typical diesel engine.

operated by a separate cam. The intake valve is held open during the intake stroke, and the exhaust valve is opened during the exhaust stroke. Since two revolutions of the crankshaft are necessary to complete a cycle, the camshaft of these engines turns only half as fast as the crankshaft.

### COMPRESSION IGNITION SYSTEM

In the four-stroke cycle engine, air enters the cylinders through intake valves. As each piston moves downward on the intake stroke, the volume in the combustion chamber increases and the

pressure decreases. The normal atmospheric pressure then forces the air into the cylinder through the intake valve.

Since the two-stroke cycle engine does not go through an intake stroke, a means must be provided to force air into the cylinders. The air enters through intake ports (uncovered when the piston approaches the bottom of the power stroke). (See fig. 7-5.) Since the exhaust valves are open when the intake ports are being uncovered, the incoming air forces the burned gases out through the exhaust valves and fills the cylinder with a supply of fresh air.



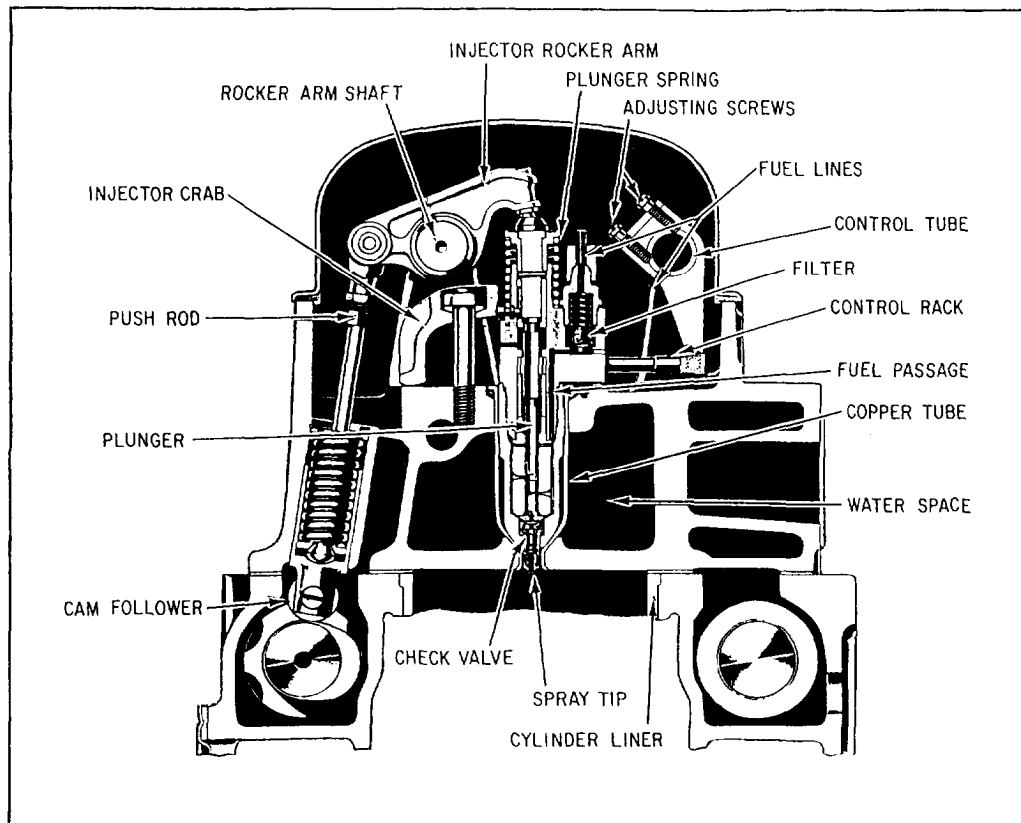

Figure 7-9.—Mounting of the unit injector in the cylinder head.

On the compression stroke, the exhaust valves are closed, the intake ports are covered, and the air is trapped in the cylinder. The rising piston compresses the air and raises its temperature. By the time the piston reaches the top of the stroke, the volume of the combustion chamber has been greatly reduced. The relation between the volume of the cylinder with the piston at the bottom of its stroke and the cylinder volume with the piston at the top of its stroke is called the **COMPRESSION RATIO**.

As the compression ratio is increased, the temperature of the air in the cylinder increases. Current gasoline engines operate at compression ratios between 6:1 and 11:1, but compression ratios of diesel engines range between 12:1 and 19:1. Remember, that on the compression stroke of a diesel engine the air is compressed to a range of 400 to 600 psi, which results in a temperature ranging from 700°F to 1200°F. However, when the fuel is injected into the cylinder and begins to burn, the pressure may increase to more than 1500 psi and the temperature may rise as high as 1800°F.

You can find more detailed information on compression ignition systems in *Engineman 3*, NAVEDTRA 10539.

## FUEL SYSTEM

The fuel system of a diesel engine draws fuel from the service tank and injects it into the engine cylinders. Figure 7-8 shows the units found in a typical unit-injector fuel system. The fuel pump draws the fuel from the tank through a primary strainer and delivers it under low pressure to the injector by way of the secondary filter. The injector is operated by a rocker arm. It meters, pressurizes, and atomizes the fuel as it is injected into the combustion chamber. The outlet line carries the excess fuel from the injector back to the fuel tank. In some units, a transfer pump is installed between the tank and the strainer. In other units, the injection pump and injection nozzles are separate units instead of a combined unit, as shown in figure 7-9.

A diesel engine will not operate efficiently unless clean fuel is delivered to the injector or

injection nozzles. As the fuel is pumped into the fuel service tanks, it is purified. From the service tank the fuel is filtered before reaching the injection system, where the larger particles of the solids suspended in the fuel are trapped in the strainer. The filter separates the fine particles of foreign matter that pass through the strainer. Most strainers have a drain plug for removing the water, sludge, and other foreign matter. The strainers should be drained once each day.

There are many methods of fuel injection and just as many types of injection pumps and nozzles. The unit injector, shown in figure 7-9, consists basically of a small cylinder and a plunger and extends through the cylinder head to the combustion chamber. A cam, located on the camshaft adjacent to the cam that operates the exhaust valves, acts through a rocker arm and depresses the plunger at the correct instant in the operating cycle.

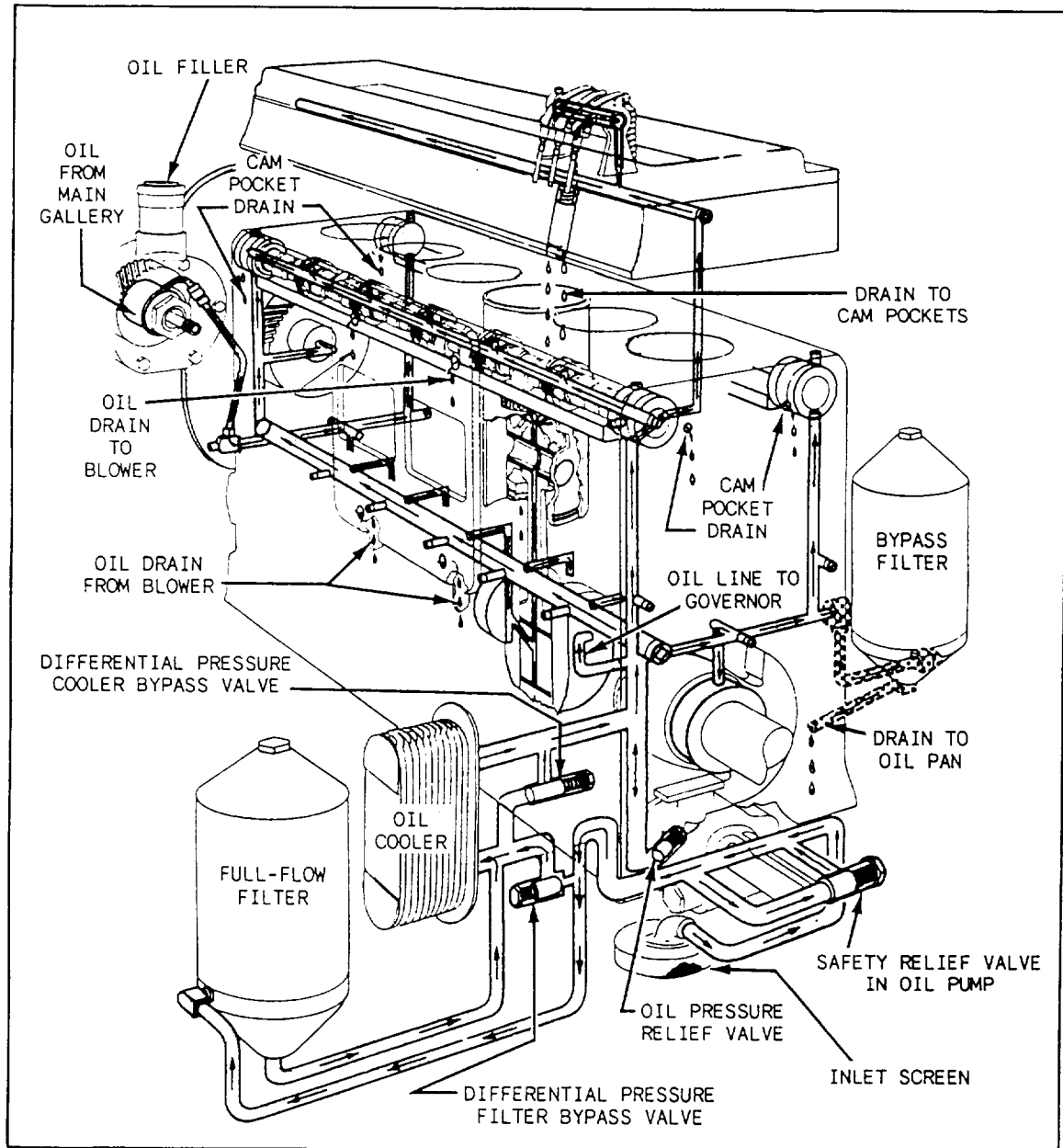

Figure 7-10.—Typical lubrication system.

When the injector plunger is depressed, a fine spray of fuel is discharged into the cylinder through small holes in the nozzle. The smooth operation of the engine depends, to a large extent, on the accuracy with which the plungers inject the same amount of fuel into every cylinder.

The amount of fuel injected into the cylinders on each stroke is controlled by rotating the plungers of a unit injector. The throttle, which regulates the speed of the engine, is connected to the injectors through a suitable linkage. A change in the throttle setting rotates the plungers and varies the amount of fuel injected into the cylinders on each stroke.

## **LUBRICATION SYSTEM**

The lubrication system of an internal-combustion engine is very important. If the lubricating system should fail, not only will the engine stop, but many of the parts are likely to be damaged beyond repair. Therefore, when lubrication failure occurs, the engine can seldom be run again without a major overhaul.

The lubricating system delivers oil to the moving parts of the engine to reduce friction and to assist in keeping the parts cool. Most diesel and gasoline engines are equipped with a pressure lubricating system that delivers the oil under pressure to the bearings and bushings and also lubricates the gears and cylinder walls. The oil usually reaches the bearings through passages drilled in the framework of the engine. The lubricating system of a typical diesel engine is shown in figure 7-10.

All of the engine parts are lubricated with oil delivered by a gear-type oil pump. This pump takes suction through a screen from an oil pan or sump. From the pump, the oil is forced through the oil filter and the oil cooler into the main oil gallery. The oil is fed from the main gallery, through individual passages, to the main crankshaft bearings and one end of the hollow camshaft. All the other moving parts and bearings are lubricated by oil drawn from these two sources. The cylinder walls and the teeth of many of the gears are lubricated by oil spray thrown off by the rotating crankshaft. After the oil has served its purpose, it drains back to the sump to be used again.

The oil pressure in the line leading from the pump to the engine is indicated on a pressure gauge. A temperature gauge in the return line provides an indirect method for indicating

variations in the temperature of the engine parts. Any abnormal drop in pressure or rise in temperature should be investigated at once. It is advisable to secure (shut down) the engine until the trouble has been located and corrected.

Constant oil pressure, throughout a wide range of engine speeds, is maintained by the oil pressure relief valve that allows the excess oil to flow back into the sump. All of the oil from the pump passes through the filter unless the oil is cold and heavy or if the filter (or oil cooler) is clogged. In such cases, the bypass valve (filter bypass valve or cooler bypass valve) is forced open; and the oil flows directly to the engine. Part of the oil fed to the engine is returned through the bypass filter, which removes flakes of metal, carbon particles, and other impurities.

## **COOLING SYSTEM**

Marine engines are equipped with a water-cooling system to carry away the excess heat produced in the engine cylinders. Fresh water (coolant) is circulated through passages in the cylinder walls and in the cylinder head, where it becomes hot from absorbing engine heat. The hot coolant then passes through a heat exchanger, where it gives up its heat to a cooling medium, becomes cool, and returns to the engine to remove more heat. The cooling medium may be either air or seawater.

A heat exchanger using air as the cooling medium works like an automobile radiator. A heat exchanger using seawater as the cooling medium may be mounted either on the engine or on the ship's hull. Engine-mounted heat exchangers require seawater to be pumped to and from them; whereas, hull-mounted heat exchangers (keel coolers) are in constant contact with seawater and require the fresh water (coolant) to be pumped through the cooler.

## **STARTING SYSTEMS**

There are three types of starting systems used in internal-combustion engines—electric, hydraulic, and compressed air.

As a Fireman, you will probably have more contact with the electric starting system than you will with the other two types. Lifeboats aboard ships use an electric starter to start the engine.

Electric starting systems use direct current because electrical energy in this form can be stored in batteries and drawn upon when needed. The battery's electrical energy can be restored by

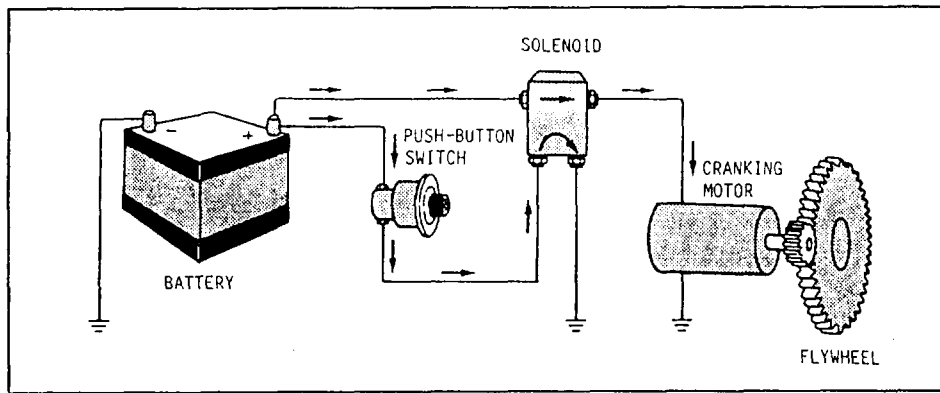

Figure 7-11.—Electric starting system.

charging the battery with an engine-driven generator.

The main components of the electric starting system, as shown in figure 7-11, are the battery, cranking motor, and associated control and protective devices.

### Electric Starting Systems

The starting motor for diesel and gasoline engines operates on the same principle as a direct current electric motor. The motor is designed to carry extremely heavy loads but, because it draws a high current (300 to 665 amperes), it tends to overheat quickly. To avoid overheating, NEVER allow the motor to run more than the specified amount of time, usually 30 seconds at a time. Then allow it to cool for 2 or 3 minutes before using it again.

To start a diesel engine, you must turn it over rapidly to obtain sufficient heat to ignite the fuel. The starting motor is located near the flywheel, and the drive gear on the starter is arranged so that it can mesh with the teeth on the flywheel when the starting switch is closed. The drive mechanism must function to (1) transmit the turning power to the engine when the starting motor runs, (2) disconnect the starting motor from the engine immediately after the engine has started, and (3) provide a gear reduction ratio between the starting motor and the engine.

The drive mechanism must disengage the pinion from the flywheel immediately after the engine starts. After the engine starts, its speed may increase rapidly to approximately 1,500 rpm. If the drive pinion remained meshed with the flywheel and also locked with the shaft of the starting motor at a normal engine speed

(1,500 rpm), the shaft would be spun at a rapid rate (22,500 to 30,000 rpm). At such speeds, the starting motor would be badly damaged.

### Hydraulic Starting Systems

There are several types of hydraulic starting systems in use. In most installations, the system consists of a hydraulic starting motor, a piston-type accumulator, a manually operated hydraulic pump, an engine-driven hydraulic pump, and a reservoir for the hydraulic fluid.

Hydraulic pressure is provided in the accumulator by the manually operated hand pump or from the engine-driven pump when the engine is operating.

When the starting lever is operated, the control valve allows hydraulic oil (under pressure of nitrogen gas) from the accumulator to pass through the hydraulic starting motor, thereby cranking the engine. When the starting lever is released, spring action disengages the starting pinion and closes the control valve. This stops the flow of hydraulic oil from the accumulator. The starter is protected from the high speeds of the engine by the action of an overrunning clutch.

The hydraulic starting system is used on some smaller diesel engines. This system can be applied to most engines now in service without modification.

### Air Starting Systems

Starting air comes directly from the ship's medium-pressure (MP) or high-pressure (HP) air service line or from the starting air flasks which are included in some systems for the purpose of storing starting air. From either source, the air,

on its way to the starting air system, must bypass through a pressure-reducing valve, which reduces the higher pressure to the operating pressure required to start a particular engine.

A relief valve is installed in the line between the reducing valve and the starting system. The relief valve is normally set to open at 12 percent above the required starting air pressure. If the air pressure leaving the reducing valve is too high, the relief valve will protect the system by releasing air in excess of a preset value and permit air only at safe pressure to reach the starting system of the engine.

**START AIR MOTOR SYSTEM.**— Some engines, usually gas turbine types, are designed to crank over by starting motors that use compressed air. Air-starting motors are usually driven by air pressures varying from 90 to 200 psi.

**COMPRESSED AIR ADMISSION SYSTEM.**— Most large diesel engines are started when compressed air is admitted directly into the engine cylinders. Compressed air at approximately 200 to 300 psi is directed into the cylinders to force the piston down and thereby, turn the crankshaft of the engine. This air admission process continues until the pistons are able to build up sufficient heat from compression to cause combustion to start the engine.

## **GASOLINE ENGINES**

The main parts of the gasoline engine are quite similar to those of the diesel engine. The two engines differ principally in that the gasoline engine has a carburetor and an electrical ignition system.

The induction system of a gasoline engine draws gasoline from the fuel tank and air from the atmosphere, mixes them, and delivers the mixture to the cylinders. The induction system consists of the fuel tank, the fuel pump, the carburetor, and the necessary fuel lines and air passages. Flexible tubing carries the fuel from the tank to the carburetor, while the intake manifold carries the fuel-air mixture from there to the individual cylinders. The fuel-air mixture is ignited by an electric spark.

The carburetor is a device used to send a fine spray of fuel into a moving stream of air as it moves to the intake valves of the cylinders. The spray is swept along, vaporized, and mixed with the moving air. The carburetor is designed to

maintain the same mixture ratio over a wide range of engine speeds. The mixture ratio is the number of pounds of air mixed with each pound of gasoline vapor. A rich mixture is one in which the percentage of gasoline vapor is high, while a lean mixture contains a low percentage of gasoline vapor.

The electrical ignition system is designed to deliver a spark in the combustion chamber of each cylinder at a specific point in that cylinder's cycle of operation. A typical ignition system includes a storage battery, an ignition coil, breaker points, a condenser, a distributor, a spark plug in each cylinder, a switch, and the necessary wiring.

There are two distinct circuits in the ignition system—the primary and the secondary. The primary circuit carries a low-voltage current. The secondary circuit is high voltage. The battery, the ignition switch, the ignition coil, and the breaker points are connected in the primary circuit. The secondary circuit, also connected to the ignition coil, includes the distributor and the spark plugs.

The storage battery is usually 6, 12, or 24 volts. One terminal is grounded to the engine frame, while the other is connected to the ignition system.

The ignition coil, in many respects, is similar to an electromagnet. It consists of an iron core surrounded by primary and secondary coils. The primary coil is made up of a few turns of heavy wire, while the secondary coil has a great many turns of fine wire. In both coils, the wire is insulated and the coils are entirely separate from each other.

The breaker points form a mechanical switch connected to the primary circuit. They are opened by a cam that is timed to break the circuit at the exact instant that each cylinder is due to fire. A condenser is connected across the breaker points to prevent arcing and to provide a better high-voltage spark.

The distributor, connected to the secondary or high-voltage circuit, serves as a selector switch that channels electric current to the individual cylinders. Although the breaker points are connected in the primary circuit, they are often located in the distributor case. The same drive shaft operates both the breaker points and the distributor.

The spark plugs, which extend into the combustion chambers of the cylinders, are connected by heavily insulated wires to the distributor. A spark plug consists essentially of a metal shell that screws into the spark plug hole in the cylinder, a center electrode embedded in

porcelain, and a side electrode connected to the shell. The side electrode is adjusted so that there is a small space (gap) between it and the center electrode. This gap varies depending on the engine. When the plug fires, an electric spark jumps across the gap between the electrodes.

When the engine is running, the electric current in the primary circuit flows from the battery through the switch, the primary winding in the ignition coil, the breaker points, and then back to the battery. The high voltage is produced in the secondary winding in the ignition coil, then flows through the distributor to the individual spark plugs and back to the ignition coil through the engine frame. It is interesting to note that the high voltage that jumps the gap in the spark plugs does not come from the battery but is produced in the ignition coil.

The ignition coil and the condenser are the only parts of the ignition system that require an explanation. The soft iron core and the primary windings function as an electromagnet. The current flowing through the primary windings magnetizes the core. The same core and the secondary windings function as a transformer. Variations in the primary current change the magnetism of the core, which in turn produces high voltage in the secondary windings.

With the engine running and the breaker points closed, low-voltage current flows through the primary circuit. When the breaker points open, this current is interrupted and produces high voltage in the secondary circuit. The electricity, which would otherwise arc across the breaker points as they are separating, now flows into the condenser.

The principal purpose of the condenser is to protect the breaker points from being burned. The condenser also aids in obtaining a hotter spark.

The contact-point ignition system is an older type. The electronic ignition system is of the newer type. The basic difference between the contact-point and the electronic ignition systems is in the primary circuit. The primary circuit in the contact-point system is opened and closed by contact points. In the electronic system, the primary circuit is opened and closed by the electronic control unit.

The secondary circuits are practically the same for the two systems. The difference is that the distributor, ignition coil, and wiring are altered to handle the higher voltage that the electronic ignition system produces.

One advantage of this higher voltage of approximately 47,000 volts is that spark plugs with wider gaps can be used. This results in a longer spark, which can ignite leaner fuel-air mixtures. As a result, engines can run on leaner mixtures for better fuel economy and lower emissions.

Another difference is that some electronic ignition systems have no mechanical advance mechanisms—centrifugal or vacuum. Instead, the spark timing is adjusted electronically.

The starting system of the gasoline engine is basically the same as that of the diesel engine. The generator keeps the battery charged and provides the current to operate the lights and other electrical equipment. The starter motor draws current from the battery and rotates the flywheel and crankshaft for starting.

## **SUMMARY**

This chapter was designed to give you a brief understanding of diesel and gasoline internal-combustion engines. You will find these engines on all ships in the Navy. It will be of great value to you to learn more about them by reading the referenced material given throughout this chapter.

## CHAPTER 8

# SHIP PROPULSION

The primary function of any marine engineering plant is to convert the chemical energy of a fuel into useful work and to use that work in the propulsion of the ship. A propulsion unit consists of the machinery, equipment, and controls that are mechanically, electrically, or hydraulically connected to a propulsion shaft. After reading this chapter, you will have a basic understanding of how a ship's propulsion unit works. You will learn about the three main types of propulsion units used in the Navy. You will also learn how power is transmitted from the propulsion unit to the ship's propeller through the use of gears, shafts, and clutches.

### PRINCIPLES OF SHIP PROPULSION

A ship moves through the water by propelling devices, such as paddle wheels or propellers. These devices impart velocity to a column of water and move it in the direction opposite to the direction in which it is desired to move the ship. A force, called reactive force because it reacts to the force of the column of water, is developed against the velocity-imparting device. This force, also called thrust, is transmitted to the ship and causes the ship to move through the water.

The screw-type propeller is the propulsion device used in almost all naval ships. The thrust developed on the propeller is transmitted to the ship's structure by the main shaft through the thrust bearing (fig. 8-1).

The main shaft extends from the main reduction gear shaft of the reduction gear to the propeller. It is supported and held in alignment by the spring bearings, the stern tube bearings, and the strut bearing. The thrust, acting on the propulsion shaft as a result of the pushing effect of the propeller, is transmitted to the ship's structure by the main thrust bearing. In most ships, the main thrust bearing is located at the forward end of the main shaft within the main reduction gear casing. In some very large ships, however, the main shaft thrust bearing is located farther aft in a machinery space or a shaft alley.

The main reduction gear connects the prime mover (engine) to the shaft. The function of the main reduction gear is to reduce the high rotational speeds of the engine and allow the propeller to operate at lower rotation speeds. In this way, both the engine and the propeller shaft rotate at their most efficient speeds.

### TYPICAL PROPULSION UNITS

Various types and designs of prime movers are currently in use on naval ships. The prime movers

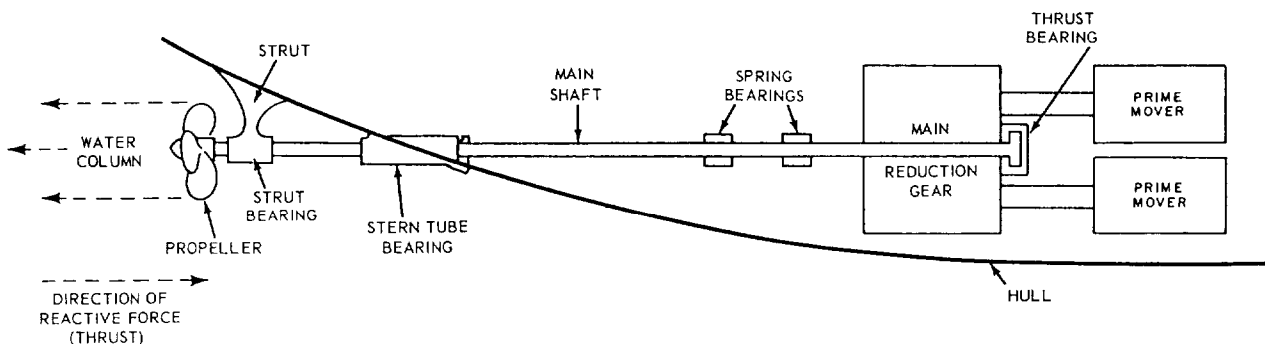

Figure 8-1.—General principle of geared ship propulsion.

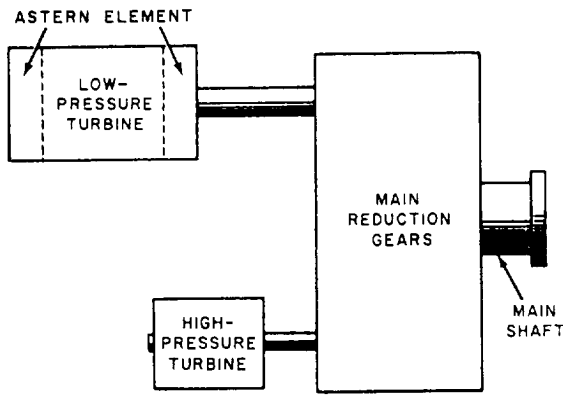

Figure 8-2.—Geared steam turbine drive.

may be either a geared turbine (steam or gas) or diesel engine.

### STEAM TURBINE GEAR DRIVE

In the steam turbine gear drive, the individual propulsion units consist of the main turbines and the main reduction gear (fig. 8-2). These types of turbine drives are used on most types of naval ships. They provide a high power-to-weight ratio and are ruggedly constructed. When repairs are

needed, they can usually be completed without removing the turbines from the ship. Steam turbine gear drives consist of one high-pressure turbine and one low-pressure turbine. They provide ahead propulsion. Smaller and simpler turbine elements inside the low-pressure turbine provide astern propulsion (fig. 8-2).

### DIESEL GEAR DRIVE

In the diesel gear drive engine, the parts that make up the unit consist of the diesel engine, the reduction gear, and either the controllable-pitch propeller unit or the dc motor/generator drive unit. The diesel gear drive engine is used on auxiliary ships, minesweepers, fleet tugs, patrol crafts, and numerous other yard craft and small boats. Standardization of fuels, cheaper fuel, and reduction in fire hazards are the chief factors why the Navy favors diesel engines.

Some diesel engines are directly reversible. The propeller shaft is connected directly to the diesel engine so that the speed of the propeller shaft is controlled by the speed of the diesel engine. When it becomes necessary to reverse the direction of rotation of the propeller shaft, the diesel engine is stopped, the cam shaft of the engine is shifted for reverse rotation, and then the engine is

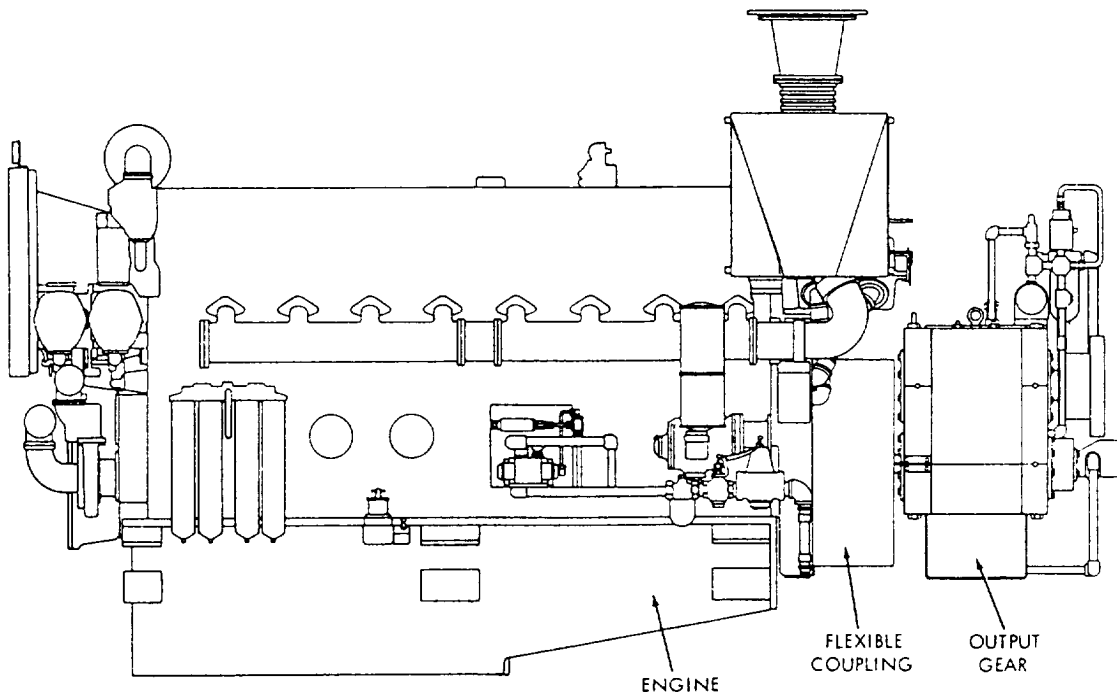

Figure 8-3.—Diesel engine and reduction gear.



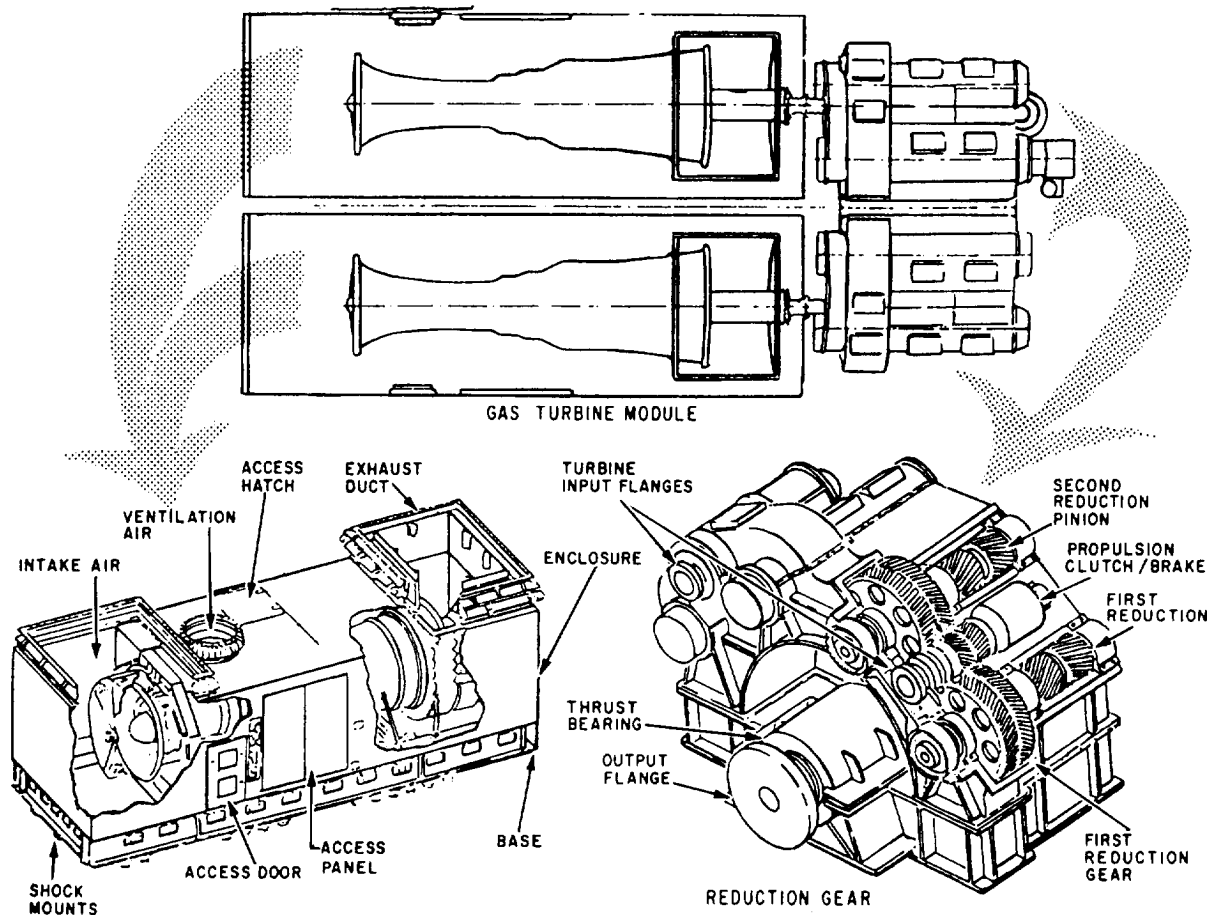

Figure 8-4.—Typical gas turbine reduction gear module arrangement.

restarted. This allows the engine to operate in the opposite direction. This operation takes time and presents a difficult situation if sudden changes in direction are required.

To eliminate this stopping-starting situation and to make a smoother transition from forward to reverse in less time, reverse-reduction gears, clutches, and controllable-pitch propellers are used. Figure 8-3 shows a typical diesel engine.

### GAS TURBINE DRIVE

Gas turbines are used on patrol craft, destroyers, cruisers, frigates, amphibious craft, and auxiliary oilers. Compared to other propulsion units, they offer a high power-to-weight ratio.

Gas turbine gear drive units consist of gas turbines, reduction gears, and controllable-pitch propeller units. Figure 8-4 shows a typical gas turbine reduction gear arrangement.

### CONVERTING POWER TO DRIVE

The basic characteristics of a propulsion unit usually make it necessary for the drive mechanism to change both the speed and the direction of shaft rotation. The engine in many installations includes a device that permits a speed reduction from the engine to the propeller shaft so that both the engine and the propeller may operate efficiently. This device is a combination of gears and is called a reduction gear.

### REDUCTION GEARS

Engines must operate at relatively high speeds for maximum efficiency. Propellers must operate at lower speeds for maximum efficiency. Therefore, reduction gears are used to allow both the engine and the propeller to operate within their most efficient revolutions per minute (rpm)

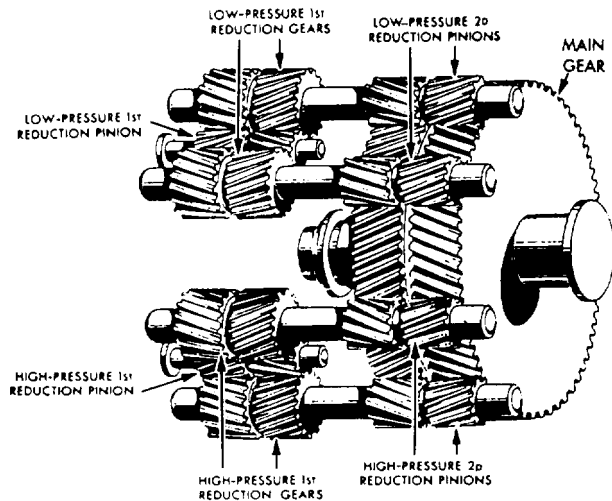

Figure 8-5.—Locked-train-type gearing.

ranges. A typical steam turbine reduction gear is shown in figure 8-5.

The use of reduction gears is by no means limited to ship propulsion. Other machinery, such as ship's service generators and various pumps, also have reduction gears. In these units, as well as in shipboard propulsion units, engine operating efficiency requires a higher rpm range than that suitable for the driven unit.

Reduction gears are classified by the number of steps used to bring about the speed reduction and the arrangement of the gearing. A gear mechanism consisting of a pair of gears or a small gear (pinion) driven by the engine shaft, which directly drives a large (bull) gear on the propeller shaft, is called a single-reduction gear. In this type of arrangement, the ratio of speed reduction is proportional to the diameter of the pinion and the gear. For example, in a 2-to-1 single-reduction gear, the diameter of the driven gear is twice that of the driving pinion. In a 10-to-1 single-reduction gear, the diameter of the driven gear is 10 times that of the driving pinion.

Steam propulsion-type ships built since 1935 have double-reduction propulsion gears. In this type of gear, a high-speed pinion, connected to the turbine shaft by a flexible coupling, drives an intermediate (first reduction) gear. This gear is connected by a shaft to the low-speed pinion that, in turn, drives the bull gear (second reduction) mounted on the propeller shaft. A 20-to-1 speed reduction might be accomplished by having a ratio of 2-to-1 between the high-speed pinion and the first-reduction gear, and a ratio of 10-to-1

between the low-speed pinion and the second-reduction gear on the propeller shaft.

For a typical example of a double-reduction application, let us consider the main-reduction gear shown in figure 8-6. The high-pressure and low-pressure turbines are connected to the propeller shaft through a locked-train type of double-reduction gear.

**NOTE:** This type of reduction gear is used aboard many naval combatant ships.

First-reduction pinions are connected by flexible couplings to the turbines. Each of the first-reduction pinions drives two first-reduction gears. A second-reduction (slow speed) pinion is attached to each of the first-reduction gears by a quill shaft and flexible couplings. These four pinions drive the second-reduction (bull) gear that is attached to the propeller shaft.

## CLUTCHES AND REVERSE GEARS

Clutches are normally used on direct-drive propulsion engines to provide a means of disconnecting the engine from the propeller shaft. In small engines, clutches are usually combined with reverse gears and are used for maneuvering the ship. In large engines, special types of clutches are used to obtain special coupling or control characteristics and to prevent torsional (twisting) vibration.

Diesel-propelling equipment on a boat or a ship must be capable of providing backing-down power as well as forward power. There are a few ships and boats in which backing down is accomplished by reversing the pitch of the propeller. Most ships, however, back down by reversing the direction of rotation of the propeller shaft. In mechanical drives, reversing the direction of rotation of the propeller shaft may be accomplished in one of two ways. You can reverse the direction of engine rotation or use the reverse gears.

Reverse gears are used on marine engines to reverse the rotation of the propeller shaft during maneuvering without reversing the rotation of the engine. They are normally used on smaller engines. If a high-output engine has a reverse gear, the gear is used for low-speed operation only and does not have full-load and full-speed capacity. For maneuvering ships with large direct-propulsion engines, the engines are reversed.

The drive mechanism of a ship or a boat is required to do more than reduce speed and reverse

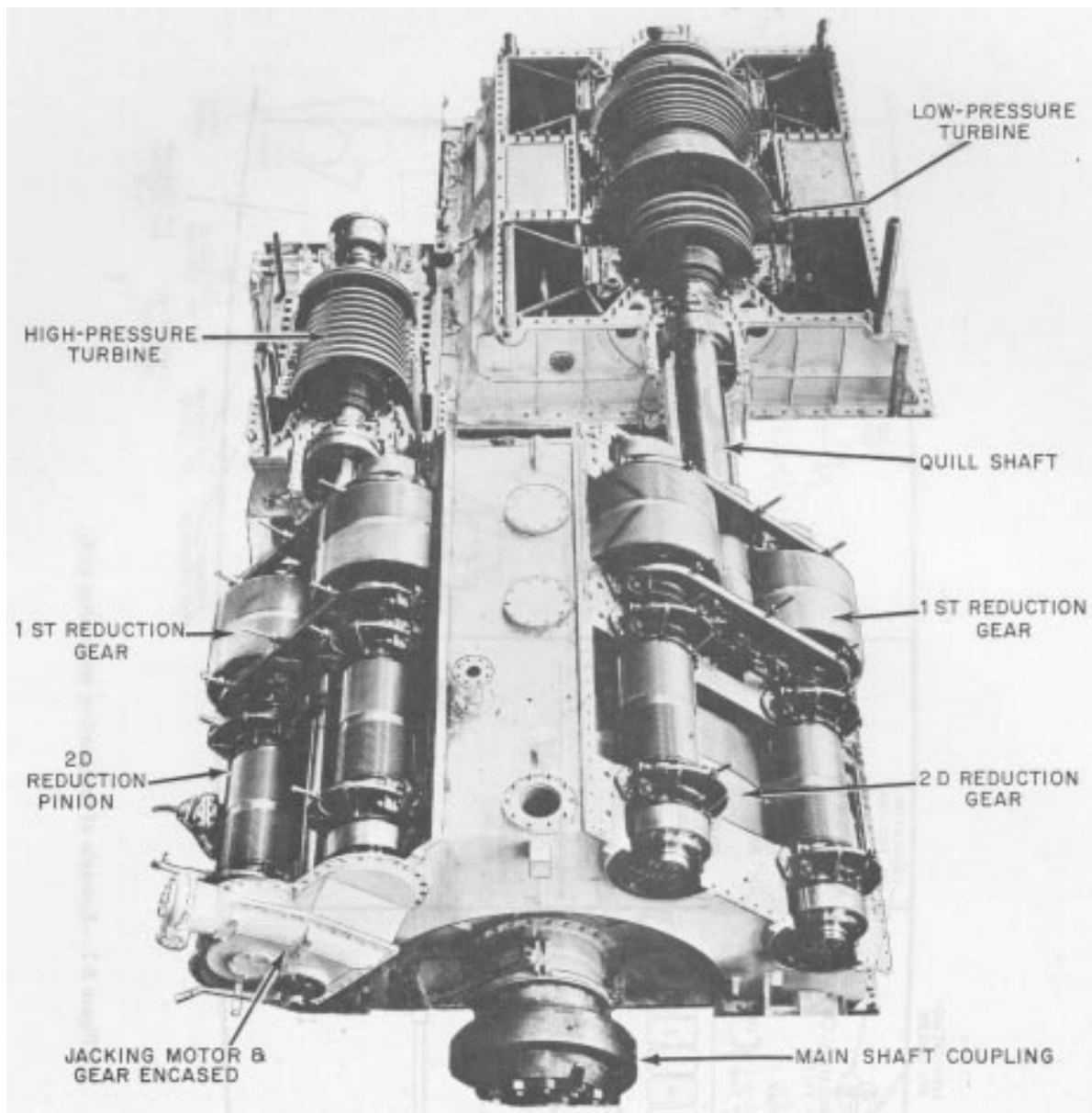

47.30

**Figure 8-6.—Typical steam turbine and reduction gear.**

the direction of shaft rotation. It is frequently necessary to operate an engine without having power transmitted to the propeller. For this reason, the drive mechanism of a ship or boat must include a means of disconnecting the engine from the propeller shaft. The devices used for this purpose are called clutches.

The arrangement of the components depends on the type and size of the installation. In some small installations, the clutch, the reverse gear

and the reduction gear may be combined in a single unit. In other installations, the clutch and the reverse gear may be in one housing and the reduction gear in a separate housing attached to the reverse-gear housing.

In large engine installations, the clutch and the reverse gear are sometimes combined and are sometimes separate units. They are located between the engine and a separate reduction gear,

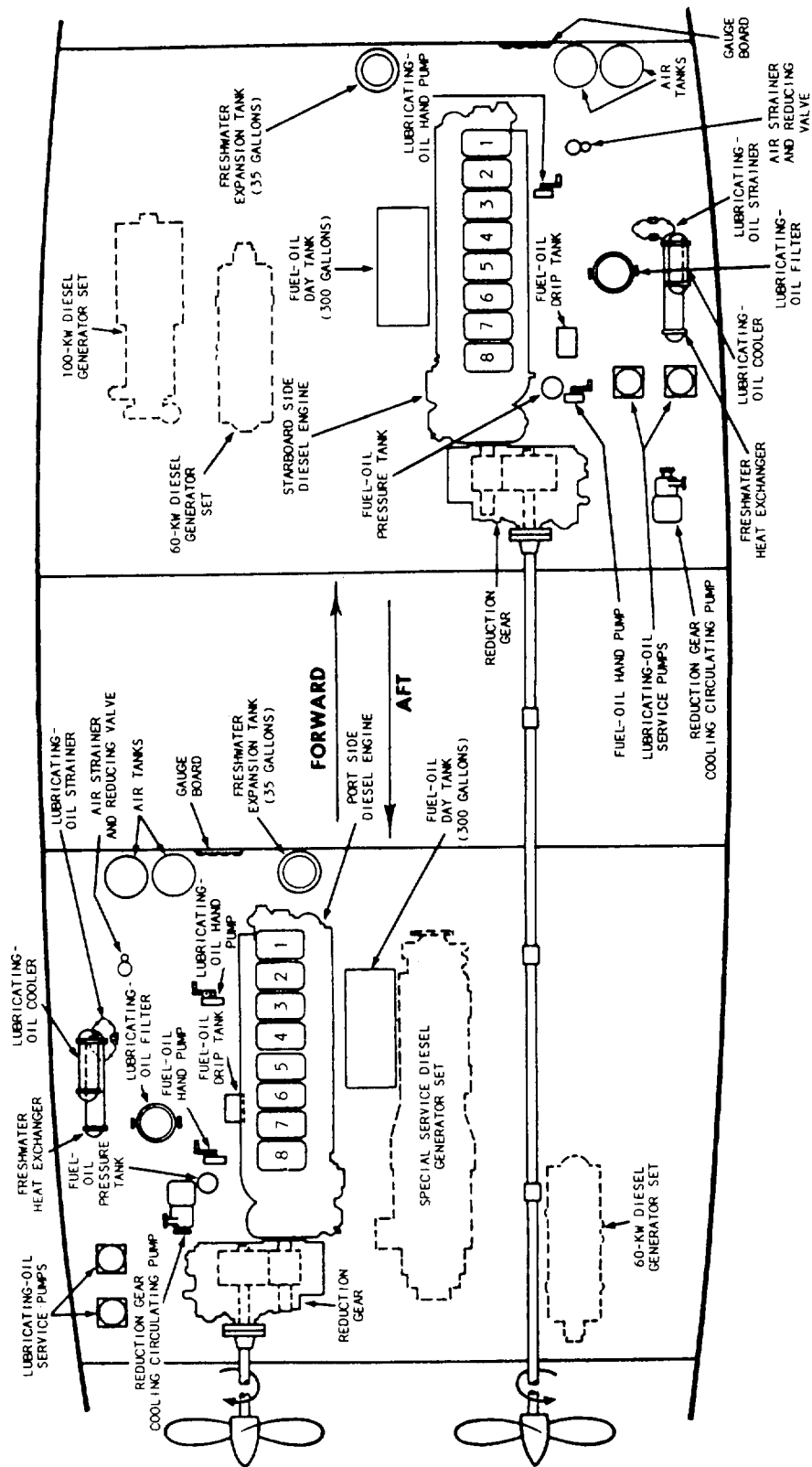

Figure 8-7.—Example of independent propulsion units.

or the clutch may be separate and the reverse gear may be combined.

In most geared-drive, multiple-propeller ships, the propulsion units are independent of each other. An example of this type of arrangement is shown in figure 8-7.

In some installations, the drive mechanism is arranged so that two or more engines drive a single propeller. This is accomplished by having the driving gear, which is on or connected to the crankshaft of each engine, transmit power to the driven gear on the propeller shaft.

Friction clutches are commonly used with smaller, high-speed engines, up to 500 horsepower (hp). Certain friction clutches, however, in combination with a jaw-type clutch, are used with engines up to 1400 hp; and pneumatic clutches with a cylindrical friction surface are used with engines up to 2000 hp.

Friction clutches are of two general styles—disk and band. In addition, friction clutches can be classified as dry or wet types, depending on whether the friction surfaces operate with or without a lubricant. The designs of both types are similar, except that the wet clutches require a large friction area. The advantages of wet clutches are smoother operation and less wear of the friction surfaces. Wear results from slippage between the surfaces during engagement and disengagement and, to a certain extent, during the operation of the mechanism. Some wet-type clutches are periodically filled with oil. In other clutches, the oil is a part of the engine-lubricating system and is circulated continuously.

### Twin-Disk Clutch and Gear Mechanism

One of the several types of transmissions used by the Navy is the Gray Marine transmission mechanism. Gray Marine high-speed diesel engines are generally equipped with a combination clutch and a reverse and reduction gear unit, all contained in a single housing at the after end of the engine.

The clutch assembly of the Gray Marine transmission mechanism is contained in the part of the housing nearest the engine. It is a dry-type, twin-disk clutch with two driving disks. Each disk is connected through shafting to a separate reduction gear train in the after part of the housing. One disk and reduction train is for reverse rotation of the shaft and propeller, and the other disk and reduction train is for forward rotation.

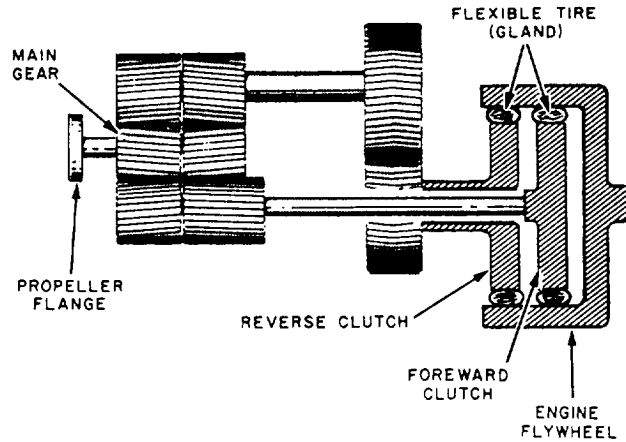

Figure 8-8.—Diagram of airflex clutch and reverse-reduction gear.

### Airflex Clutch and Gear Assembly

On the larger diesel-propelled ships, the clutch, reverse, and reduction gear unit has to transmit an enormous amount of power. To maintain the weight and size of the mechanism as low as possible, special clutches have been designed for large diesel installations. One of these is the airflex clutch and gear assembly used with engines on LSTs.

A typical airflex clutch and gear assembly for ahead and astern rotation is shown in figure 8-8. There are two clutches, one for forward rotation and one for reverse rotation. The clutches, bolted to the engine flywheel, rotate at all times with the engine at engine speed. Each clutch has a flexible tire (or gland) on the inner side of a steel shell. Before the tires are inflated, they will rotate out of contact with the drums, which are keyed to the forward and reverse drive shafts. When air under pressure (100 psi) is sent into one of the tires, the inside diameter of the clutch decreases. This causes the friction blocks on the inner tire surface to come in contact with the clutch drum, locking the drive shaft with the engine.

### Hydraulic Clutches or Couplings

The fluid clutch (coupling) is widely used on Navy ships. The use of a hydraulic coupling eliminates the need for a mechanical connection between the engine and the reduction gears. Couplings of this type operate with a small amount of slippage.

Some slippage is necessary for operation of the hydraulic coupling, since torque is transmitted because of the principle of relative motion between the two rotors. The power loss resulting from the small amount of slippage is transformed into heat that is absorbed by the oil in the system.

Compared with mechanical clutches, hydraulic clutches have a number of advantages. There is no mechanical connection between the driving and driven elements of the hydraulic coupling. Power is transmitted through the coupling very efficiently (97 percent) without transmitting torsional vibrations or load shocks from the engine to the reduction gears. This arrangement protects the engine, the gears, and the shaft from sudden shock loads that may occur as a result of piston seizure or fouling of the propeller. The power is transmitted entirely by the circulation of a driving fluid (oil) between radial passages in a pair of rotors. In addition, the assembly of the hydraulic coupling will allow for slight misalignment.

## PROPELLER

The screw-type propeller consists of a hub and blades all spaced at equal angles about the axis. When the blades are integral with the hub, the propeller is known as a solid propeller. When the blades are separately cast and secured to the hub with studs, the propeller is known as a built-up propeller.

Some of the parts of the screw propeller are identified in figure 8-9. The face (or pressure face) is the afterside of the blade when the ship is moving ahead. The back (or suction back) is the surface opposite the face. As the propeller rotates, the face of the blade increases pressure on the

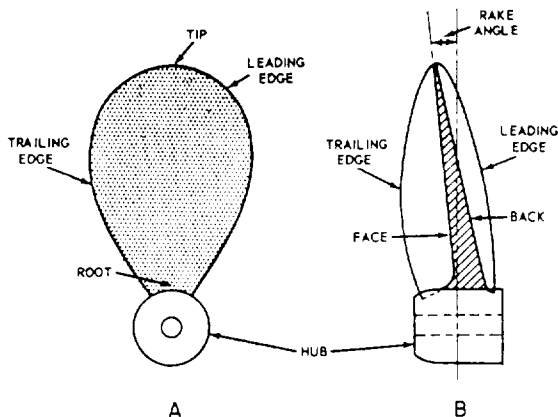

Figure 8-9.—Propeller blade.

water to move it in a positive astern movement. The overall thrust, or reaction force ahead, comes from the increased water velocity moving astern.

The tip of the blade is the most distant from the hub. The root of the blade is the area where the blade joins the hub. The leading edge is the edge that first cuts the water when the ship is going ahead. The trailing edge (also called the following edge) is opposite the leading edge.

A rake angle exists when the tip of the propeller blade is not precisely perpendicular to the axis (hub). The angle is formed by the distance between where the tip really is (forward or aft) and where the tip would be if it were in a perpendicular position.

A screw propeller may be broadly classified as either fixed pitch or controllable pitch. The pitch of a fixed-pitch propeller cannot be altered during operation. The pitch of a controllable-pitch propeller can be changed at any time, subject to bridge or engine-room control. The controllable-pitch propeller can reverse the direction of a ship without requiring a change of direction of the drive shaft. The blades are mounted so that each one can swivel or turn on a shaft that is mounted in the hub (as shown in fig. 8-10).

## SUMMARY

This chapter has provided you with some basic information on several types of propulsion systems used on Navy ships. You should become familiar with the propulsion system on your ship. Keep in mind, the propulsion systems are usually a little different from ship to ship.

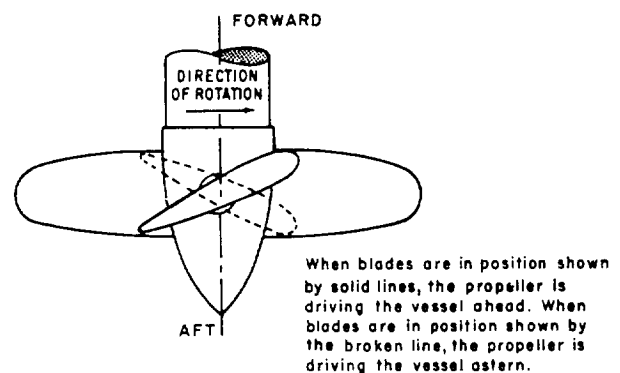

Figure 8-10.—Schematic diagram of a controllable-pitch propeller.

## CHAPTER 9

# PUMPS, VALVES, AND PIPING

As a Fireman, you must have a general knowledge of the basic operating principles of various types of pumps and supporting components, such as the different types of valves and piping used aboard ships.

Aboard ship, pumps, valves, and piping are used for a number of essential services. They supply water to the boilers, draw condensate from the condensers, supply seawater to the firemain, circulate cooling water for coolers and condensers, pump out bilges, transfer fuel oil, supply seawater to the distilling plants, and are used for many other purposes. The operation of the ship's propulsion plant and of almost all the auxiliary machinery depends on the proper operation of pumps. Although most plants have two pumps, a main pump and a standby pump, pump failure may cause failure of an entire power plant.

With the knowledge gained in this chapter, you should be able to describe pumps, valves, and piping systems in terms of their construction, function, and operation. The information in this chapter, as it is throughout the book, is of a broad and general nature. You should refer to the appropriate manufacturer's technical manuals and/or ship's plans, information books, and plant or valve manuals for specific problems with individual equipment. By studying this material, you should be able to relate to the specific equipment found on your ship.

### PUMPS

Pumps are vitally important to the operation of your ship. If they fail, the power plant they serve also fails. In an emergency, pump failures can prove disastrous. Maintaining pumps in an efficient working order is a very important task of the engineering department. As a Fireman, you must have a general knowledge of the basic

operating principles of the various types of pumps used by the Navy.

It is not practical or necessary to mention all of the various locations where pumps are found aboard ship. You will learn their location and operation as you perform your duties. The pumps with which you are primarily concerned are used for such purposes as

- providing fuel oil to the prime mover,
- circulating lubricating (lube) oil to the bearings and gears of the MRG,
- supplying seawater for the coolers in engineering spaces,
- pumping out the bilges, and
- transferring fuel oil to various storage and service tanks.

### CLASSIFICATION OF PUMPS

Pumps aboard ship outnumber all other auxiliary machinery units. They include such types as centrifugal, rotary, and jet pumps. In the following section we discuss these different pumps and their application to the engineering plant.

#### Centrifugal Pumps

Aboard gas turbine ships, centrifugal pumps of various sizes are driven by electric motors to move different types of liquid. The fire pump and seawater service pump are two examples of this type of pump.

A basic centrifugal pump has an impeller keyed to a drive shaft, which is rotated by an electric motor. The drive shaft is fitted inside a casing, which has a suction inlet and a discharge

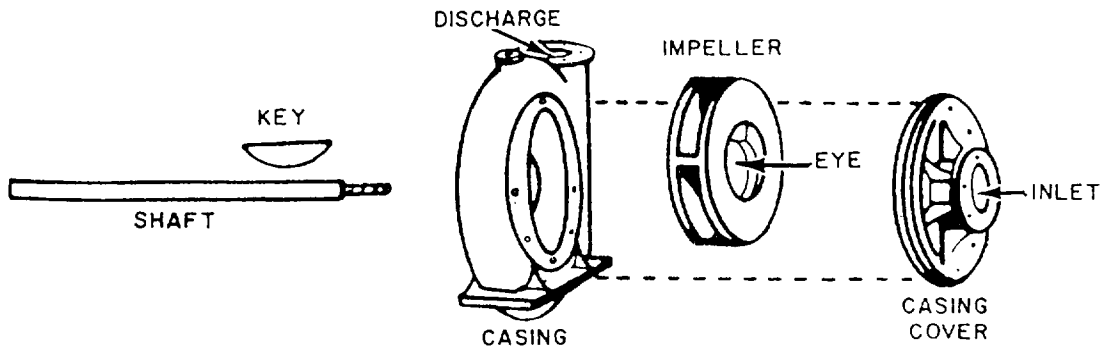

Figure 9-1.—Centrifugal pump.

outlet. Figure 9-1 shows the arrangement of components in a centrifugal pump.

**CENTRIFUGAL PUMP CLASSIFICATION.**— Centrifugal pumps may be classified in several ways. For example, they may be either single-stage or multistage. A single-stage pump has only one impeller; a multistage pump has two or more impellers housed together in one casing. In a multistage pump, each impeller usually acts separately, discharging to the suction of the next-stage impeller. Centrifugal pumps are also classified as horizontal or vertical, depending on the position of the pump shaft.

Impellers used in centrifugal pumps may be classified as single-suction or double-suction, depending on the way in which liquid enters the eye of the impeller. Figure 9-2 shows single-suction and double-suction arrangements of centrifugal pump impellers. The single-suction impeller (view A) allows liquid to enter the eye from one side only; the double-suction impeller (view B) allows liquid to enter the eye from both sides. The double-suction arrangement has the advantage of balancing the end thrust in one direction with the end thrust in the other direction.

Impellers are also classified as CLOSED or OPEN. A closed impeller has side walls that extend from the eye to the outer edge of the vane tips; an open impeller does not have side walls. Most centrifugal pumps used in the Navy have closed impellers.

**CONSTRUCTION.**— As a rule, the casing for the liquid end of a pump with a single-suction impeller is made with an end plate that can be removed for inspection and repair of the pump. A pump with a double-suction impeller is generally

made so one-half of the casing may be lifted without disturbing the pump.

Since an impeller rotates at high speed, it must be carefully machined to minimize friction. An impeller must be balanced to avoid vibration. A close radial clearance must be maintained between

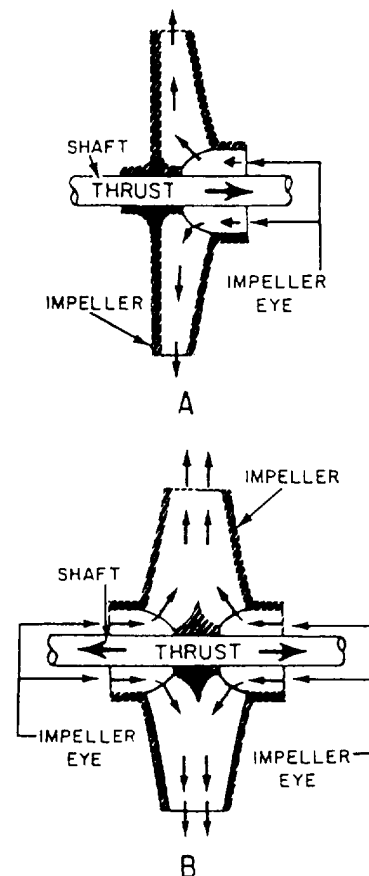

Figure 9-2.—Centrifugal pump impellers. A. Single-suction. B. Double-suction.



the outer hub of the impeller and that part of the pump casing in which the hub rotates. The purpose of this is to minimize leakage from the discharge side of the pump casing to the suction side.

Because of the high rotational speed of the impeller and the necessarily close clearance, the rubbing surfaces of both the impeller hub and the casing at that point are subject to stress, causing rapid wear. To eliminate the need for replacing an entire impeller and pump casing solely because of wear in this location, most centrifugal pumps are designed with replaceable casing wearing rings.

In most centrifugal pumps, the shaft is fitted with a replaceable sleeve. The advantage of using a sleeve is that it can be replaced more economically than the entire shaft.

Mechanical seals and stuffing boxes are used to seal between the shaft and the casing. Most pumps are now furnished with mechanical seals; mechanical seals do not result in better pump operation; but, they do provide a better environment, keep bilges dry, and preserve the liquid being pumped.

Seal piping (liquid seal) is installed to cool the mechanical seal. Most pumps in saltwater service with total head of 30 psi or more are also fitted with cyclone separators. These separators use centrifugal force to prevent abrasive material (such as sand in the seawater) from passing between the sealing surfaces of the mechanical seal. There is an opening at each end of the separator. The opening at the top is for "clean" water, which is directed through tubing to the mechanical seals in the pump. The high-velocity "dirty" water is directed through the bottom of the separator, back to the inlet piping for the pump.

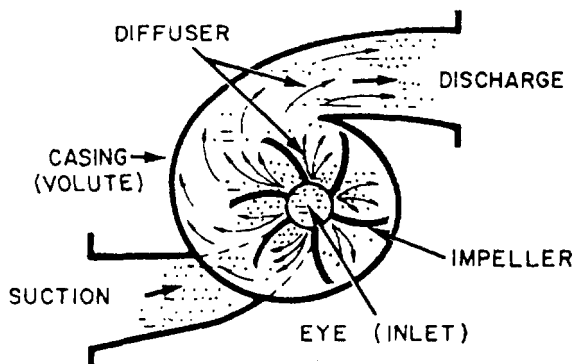

Figure 9-3.—Centrifugal pump flow.

Bearings support the weight of the impeller and shaft and maintain the position of the impeller—both radially and axially. Some bearings are grease-lubricated with grease cups to allow for periodic relubrication.

The power end of the centrifugal pump you are to work with has an electric motor that is maintained by your ship's Electrician's Mate.

**OPERATION.**— Liquid enters the rotating impeller on the suction side of the casing and enters the eye of the impeller (fig. 9-3). Liquid is thrown out through the opening around the edge of the impeller and against the side of the casing by centrifugal force. This is where the pump got its name. When liquid is thrown out to the edge of the casing, a region of low pressure (below atmospheric) is created around the center of the impeller; more liquid moves into the eye to replace the liquid that was thrown out. Liquid moves into the center of the impeller with a high velocity (speed). Therefore, liquid in the center of the impeller has a low pressure, but it is moving at a high velocity.

Liquid moving between the blades of the impeller spreads out, which causes the liquid to slow down. (Its velocity decreases.) At the same time, as the liquid moves closer to the edge of the casing, the pressure of the liquid increases. This change (from low pressure and high velocity at the center to high pressure and low velocity at the edge) is caused by the shape of the opening between the impeller blades. This space has the shape of a diffuser, a device that causes the velocity-pressure relationship of any fluid that moves through it to change.

A centrifugal pump is considered to be a nonpositive-displacement pump because the volume of liquid discharged from the pump changes whenever the pressure head changes. The pressure head is the combined effect of liquid weight, fluid friction, and obstruction to flow. In a centrifugal pump, the force of the discharge pressure of the pump must be able to overcome the force of the pressure head; otherwise, the pump could not deliver any liquid to a piping system. The pressure head and the discharge pressure of a centrifugal pump oppose each other. When the pressure head increases, the discharge pressure of the pump must also increase. Since no energy can be lost, when the discharge pressure of the pump increases, the velocity of flow must decrease. On the other hand, when the pressure head decreases, the volume of liquid discharged from the pump increases. As a general rule, a

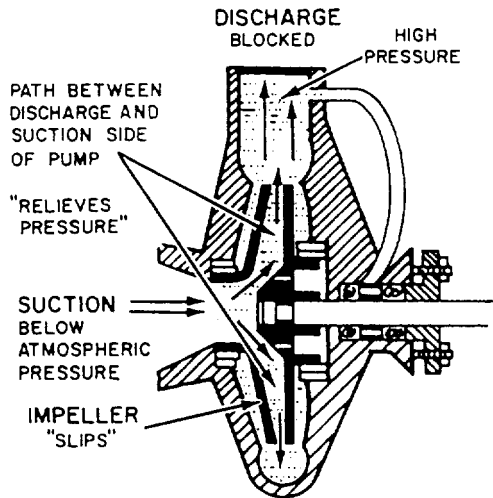

Figure 9-4.—Nonpositive-displacement pump.

centrifugal pump is usually located below the liquid being pumped. (NOTE: This discussion assumes a constant impeller speed.)

Figure 9-4 shows that when the pump discharge is blocked, nothing happens because the impeller is hollow. A tremendous buildup in pressure cannot occur because the passages in the impeller (between the discharge and suction side of the pump) act like a built-in relief valve. When the discharge pressure and pressure head are equal (as in this case), the impeller is allowed to rotate (slips) through the liquid in the casing.

**NOTE:** Centrifugal pumps used for intermittent service may have to run for long periods of time against a blocked discharge. Friction between the impeller and the liquid raises the temperature of the liquid in the casing and causes the pump to overheat. To prevent this, a small line is connected between the discharge and the suction piping of the pump.

When a centrifugal pump is started, the vent line must be opened to release entrained air. The open passage through the impeller of a centrifugal pump also causes another problem. It's possible for liquid to flow backwards (reverse flow) through the pump. A reverse flow, from the discharge back to the suction, can happen when the pressure head overcomes the discharge pressure of the pump. A reverse flow can also occur when the pump isn't running and another pump is delivering liquid to the same piping system. To prevent a reverse flow of liquid through a centrifugal pump, a check valve is usually installed in the discharge line.

**NOTE:** Instead of two separate valves, some installations use a globe stop-check valve.

With a check valve in the discharge line, whenever the pressure above the disk rises above the pressure below it, the check valve shuts. This prevents liquid from flowing backwards through the pump.

**MAINTENANCE.**— You must observe the operation and safety precautions pertaining to pumps by following the EOP subsystem of the EOSS—if your ship has EOSS. If not, use the *Naval Ships' Technical Manual (NSTM)* and/or the instructions posted on or near each individual pump. You must follow the manufacturer's technical manual or MRCs for PMS-related work for all maintenance work. The MRCs list in detail what you have to do for each individual maintenance requirement.

**Mechanical Seals.**— Mechanical seals are rapidly replacing conventional packing as the means of controlling leakage on centrifugal pumps. Pumps fitted with mechanical seals eliminate the problem of excessive stuffing box leakage, which can result in pump and motor bearing failures and motor winding failures.

Where mechanical shaft seals are used, the design ensures that positive liquid pressure is supplied to the seal faces under all conditions of operation and that there is adequate circulation of the liquid at the seal faces to minimize the deposit of foreign matter on the seal parts.

One type of mechanical seal is shown in figure 9-5. Spring pressure keeps the rotating seal face

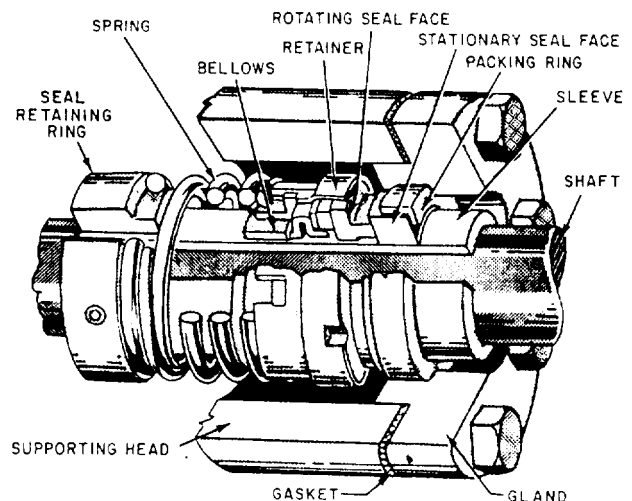

Figure 9-5.—Type-1 mechanical seal.

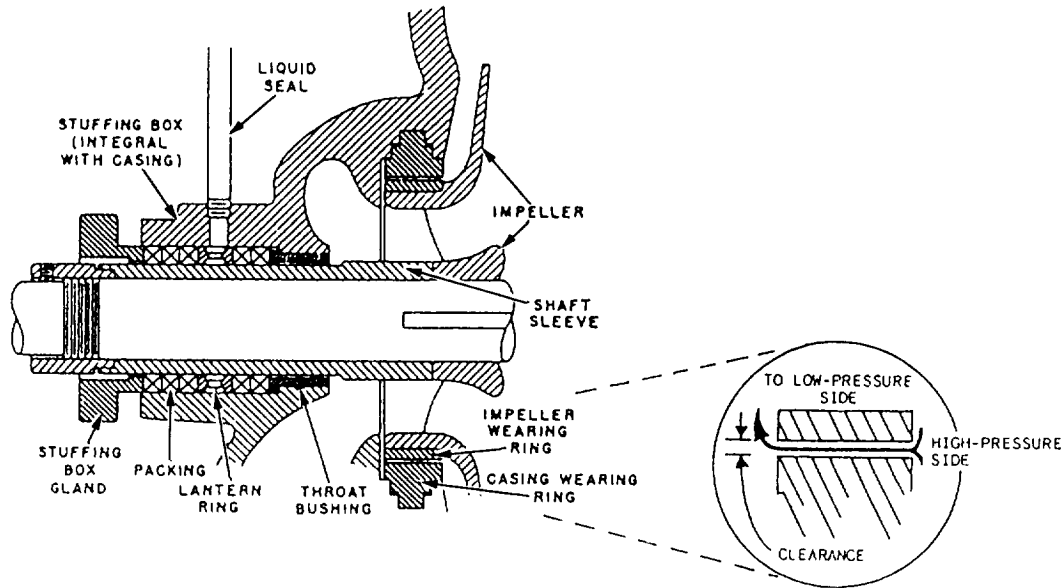

Figure 9-6.—Stuffing box on a centrifugal pump.

snug against the stationary seal face. The rotating seal and all of the assembly below it are affixed to the pump shaft. The stationary seal face is held stationary by the seal gland and packing ring. A static seal is formed between the two seal faces and the sleeve. System pressure within the pump assists the spring in keeping the rotating seal face tight against the stationary seal face. The type of material used for the seal face depends on the service of the pump. When a seal wears out, it is simply replaced.

You should observe the following precautions when performing maintenance on mechanical seals:

- Do not touch new seals on the sealing face because body acid and grease can cause the seal face to prematurely pit and fail.
- Replace mechanical seals when the seal is removed for any reason or when the leakage rate cannot be tolerated.
- Position mechanical shaft seals on the shaft by stub or step sleeves. Shaft sleeves are chamfered (beveled) on outboard ends to provide ease of mechanical seal mounting.
- Do not position mechanical shaft seals by using setscrews.

Fire pumps and all seawater pumps installed in surface ships are being provided with mechanical

shaft seals with cyclone separators. The glands are designed to incorporate two or more rings of packing if the mechanical shaft seal fails.

A water flinger is fitted on the shaft outboard of the stuffing box glands to prevent leakage from the stuffing box following along the shaft and entering the bearing housings. They must fit tightly on the shaft. If the flingers are fitted on the shaft sleeves instead of on the shaft, ensure that no water leaks under the sleeves.

**Stuffing Box Packing.**— Although most centrifugal pumps on gas turbine ships have mechanical seals, you should be familiar with stuffing box packing.

The packing in centrifugal pump stuffing boxes (fig. 9-6) is renewed following the PMS. When replacing packing, be sure to use packing of the specified material and the correct size. Stagger the joints in the packing rings so they fall at different points around the shaft. Pack the stuffing box loosely and set up lightly on the gland, allowing a liberal leakage. With the pump in operation, tighten the glands and gradually compress the packing. It is important to do this gradually and evenly to avoid excessive friction. Uneven tightening could cause overheating and possible scoring of the shaft or the shaft sleeve.

On some centrifugal pumps, a lantern ring is inserted between the rings of the packing. When repacking stuffing boxes on such pumps, be sure to replace the packing beyond the lantern ring.

The packing should not block off the liquid seal line connection to the lantern ring after the gland has been tightened.

Figure 9-6 shows how the packing is arranged. Notice how the lantern ring lines up with the liquid seal connection when the gland is tightened.

**Renewing Shaft Sleeves.**— In some pumps the shaft sleeve is pressed onto the shaft tightly by a hydraulic press. In this case, the old sleeve must be machined off with a lathe before a new one can be installed. On others, the shaft sleeve may have a snug slip-on fit, butted up against a shoulder on the shaft and held securely in place with a nut. On smaller pumps, new sleeves can be installed by removing the water end casing, impeller, and old shaft sleeves. New sleeves are carried as repair parts; they can also be made in the machine shop. On a large pump, the sleeve is usually pressed on; the old sleeve must be machined off before a new one can be pressed on. You must disassemble the pump and take the sleeve to a machine shop, a repair shop, or a naval shipyard to have this done.

To prevent water leakage between the shaft and the sleeve, some sleeves are packed, others have an O-ring between the shaft and the abutting shoulder. For detailed information, consult the appropriate manufacturer's technical manual or applicable blueprint.

**Renewing Wearing Rings.**— The clearance between the impeller and the casing wearing ring (fig. 9-7) must be maintained as directed by the manufacturer. When clearances exceed the specified amount, the casing wearing ring must be replaced. On most ships, this job can be done

by the ship's force, but it requires the complete disassembly of the pump. All necessary information on disassembly of the unit, dimensions of the wearing rings, and reassembly of the pump is specified by PMS or can be found in the manufacturer's technical manual. Failure to replace the casing wearing ring when the allowable clearance is exceeded results in a decrease of pump capacity and efficiency. If a pump has to be disassembled because of some internal trouble, the wearing ring should be checked for clearance. Measure the outside diameter of the impeller hub with an outside micrometer and the inside diameter of the casing wearing ring with an inside micrometer; the difference between the two diameters is the actual wearing ring diametric clearance. By checking the actual wearing ring clearance with the maximum allowable clearance, you can decide whether to renew the ring before reassembling the pump. The applicable MRCs area readily available source of information on proper clearances.

Wearing rings for most small pumps are carried aboard ship as part of the ship's repair parts allowance. These may need only a slight amount of machining before they can be installed. For some pumps, spare rotors are carried aboard ship. The new rotor can be installed and the old rotor sent to a repair activity for overhaul. Overhauling a rotor includes renewing the wearing rings, bearings, and shaft sleeve.

**Operating Troubles.**— You will be responsible for the maintenance of centrifugal pumps. The following table is a description of some of the problems you will have to deal with together with the probable causes:

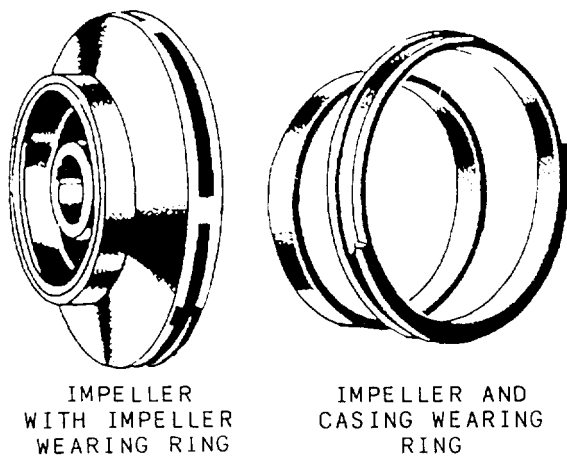

Figure 9-7.—Impeller, impeller wearing ring, and casing wearing ring for a centrifugal pump.

<u>TROUBLE</u>	<u>CAUSE</u>
Does not deliver any liquid	Insufficient priming Insufficient speed of the pump Excessive discharge pressure (such as a partially closed valve or some other obstruction in the discharge line) Excessive suction lift Clogged impeller passages Wrong direction of rotation Clogged suction screen (if used) Ruptured suction line Loss of suction pressure

<u>TROUBLE</u>	<u>CAUSE</u>
Insufficient capacity	Air leakage into the suction line
	Insufficient speed of the pump
	Excessive suction lift
	Clogged impeller passages
	Excessive discharge pressure
	Mechanical defects (such as worn wearing rings, impellers, stuffing box packing, or sleeves)
Does not develop enough discharge pressure	Insufficient speed of the pump
	Air or gas in the liquid being pumped
	Mechanical defects (such as worn wearing rings, impellers, leaking mechanical seals, and sleeves)
Works for a while and then fails to deliver liquid	Air leakage into the suction line
	Air leakage in the stuffing boxes
	Clogged water seal passages
	Insufficient liquid on the suction side
	Excessive heat in the liquid being pumped
	Operation of the pump at excess capacity and insufficient discharge pressure
Takes too much power and the motor overheats	Misalignment
	Bent shaft
	Excessively tight stuffing box packing
	Worn wearing rings
	Other mechanical defects

<u>TROUBLE</u>	<u>CAUSE</u>
Vibration	Misalignment
	Bent shaft
	Clogged, eroded, or otherwise unbalanced impeller
	Lack of rigidity in the foundation
Insufficient suction pressure may also cause vibration, as well as noisy operation and fluctuating discharge pressure.	

### **Rotary Pumps**

Another type of pump you find aboard ship is the rotary pump. A number of types are included in this classification, among which are the gear pump, the screw pump, and the moving vane pump. Unlike the centrifugal pump, which we have discussed, the rotary pump is a positive-displacement pump. This means that for each revolution of the pump, a fixed volume of fluid is moved regardless of the resistance against which the pump is pushing. As you can see, any blockage in the system could quickly cause damage to the pump or a rupture of the system. You, as a pump operator, must always be sure that the system is properly aligned so a complete flow path exists for fluid flow. Also, because of their positive displacement feature, rotary pumps require a relief valve to protect the pump and piping system. The relief valve lifts at a preset pressure and returns the system liquid either to the suction side of the pump or back to the supply tank or sump.

Rotary pumps are also different from centrifugal pumps in that they are essentially self-priming. As we saw in our discussion of centrifugal pumps, the pump is located below the liquid being pumped; gravity creates a static pressure head which keeps the pump primed. A rotary pump operates within limits with the pump located above the source of supply.

A good example of the principle that makes rotary pumps self-priming is the simple drinking straw. As you suck on the straw, you lower the air pressure inside the straw. Atmospheric pressure on the surface of the liquid surrounding the straw is therefore greater and forces the liquid up the straw. The same conditions basically exist for the gear and screw pump to prime itself.

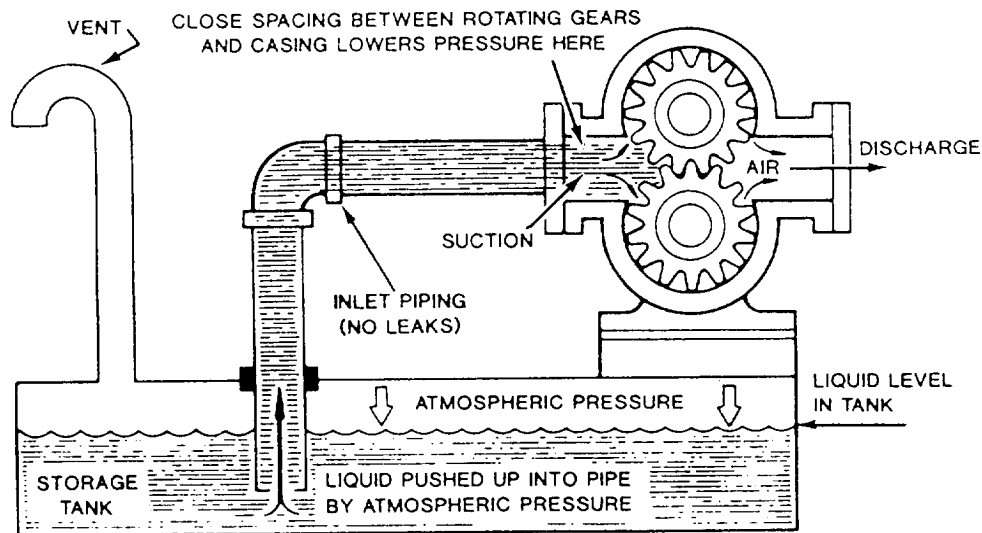

Figure 9-8.—Gear pump located above the tank.

Figure 9-8 shows a gear pump located above the tank. The tank must be vented to allow air into the tank to provide atmospheric pressure on the surface of the liquid. To lower the pressure on the suction side of the pump, the clearances between the pump parts must be close enough to pump air. When the pump starts, the air is pumped through the discharge side of the pump and creates the low-pressure area on the suction side, which allows the atmospheric pressure to force the liquid up the pipe to the pump. To operate properly, the piping leading to the pump must have no leaks or it will draw in air and can lose its prime.

Rotary pumps are useful for pumping oil and other heavy viscous liquids. In the engine room, rotary pumps are used for handling lube oil and fuel oil and are suitable for handling liquids over a wide range of viscosities.

Rotary pumps are designed with very small clearances between rotating parts and stationary parts to minimize leakage (slippage) from the discharge side back to the suction side. Rotary pumps are designed to operate at relatively slow speeds to maintain these clearances; operation at higher speeds causes erosion and excessive wear, which result in increased clearances with a subsequent decrease in pumping capacity.

Classification of rotary pumps is generally based on the types of rotating element. In the following paragraphs, the main features of some common types of rotary pumps are described.

**GEAR PUMPS.**— The simple gear pump (fig. 9-9) has two spur gears that mesh together and revolve in opposite directions. One is the driving gear, and the other is the driven gear. Clearances between the gear teeth (outside diameter of the gear) and the casing and between the end face and the casing are only a few thousandths of an inch. As the gears turn, the gears unmesh and liquid flows into the pockets that are vacated by the meshing gear teeth. This creates the suction that draws the liquid into the pump. The liquid is then carried along in the pockets formed by the gear teeth and the casing. On the discharge side, the liquid is displaced by the meshing of the gears and forced out through the discharge side of the pump.

One example of the use of a gear pump is in the LM2500 engine fuel pump. However, gear pumps are not used extensively on gas turbine ships.

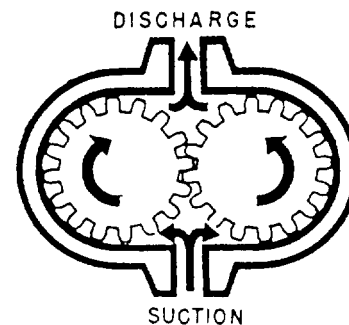

Figure 9-9.—Simple gear pump.

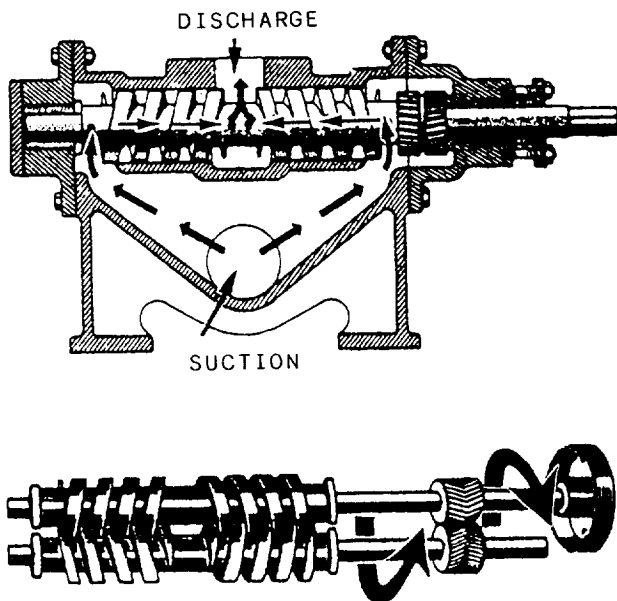

Figure 9-10.—Double-screw, low-pitch pump.

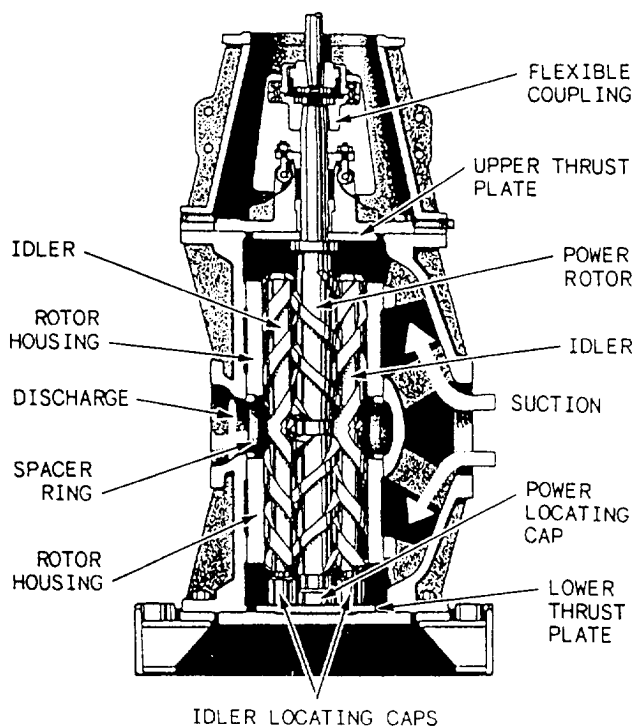

Figure 9-11.—Triple-screw, high-pitch pump.

**SCREW PUMPS.**— Several different types of screw pumps exist. The differences between the various types are the number of intermeshing screws and the pitch of the screws. Figure 9-10 shows a double-screw, low-pitch pump; and figure 9-11 shows a triple-screw, high-pitch pump. Screw

pumps are used aboard ship to pump fuel and lube oil and to supply pressure to the hydraulic system. In the double-screw pump, one rotor is driven by the drive shaft and the other by a set of timing gears. In the triple-screw pump, a central rotor meshes with two idler rotors.

In the screw pump, liquid is trapped and forced through the pump by the action of rotating screws. As the rotor turns, the liquid flows in between the threads at the outer end of each pair of screws. The threads carry the liquid along within the housing to the center of the pump where it is discharged.

Most screw pumps are now equipped with mechanical seals. If the mechanical seal fails, the stuffing box has the capability of accepting two rings of conventional packing for emergency use.

**SLIDING VANE PUMPS.**— The sliding-vane pump (fig. 9-12) has a cylindrically bored housing with a suction inlet on one side and a discharge outlet on the other side. A rotor (smaller in diameter than the cylinder) is driven about an axis that is so placed above the center line of the cylinder as to provide minimum clearance between the rotor and cylinder at the top and maximum clearance at the bottom.

The rotor carries vanes (which move in and out as the rotor rotates) to maintain sealed spaces between the rotor and the cylinder wall. The vanes trap liquid on the suction side and carry it to the discharge side, where contraction of the space expels liquid through the discharge line. The vanes slide on slots in the rotor. Vane pumps are used for lube oil service and transfer, tank stripping, bilge, aircraft fueling and defueling and, in general, for handling lighter viscous liquids.

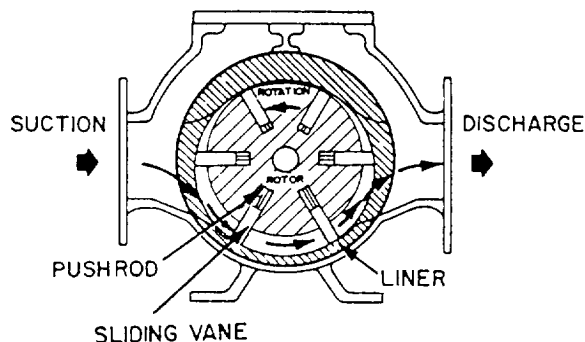

Figure 9-12.—Sliding vane pump.

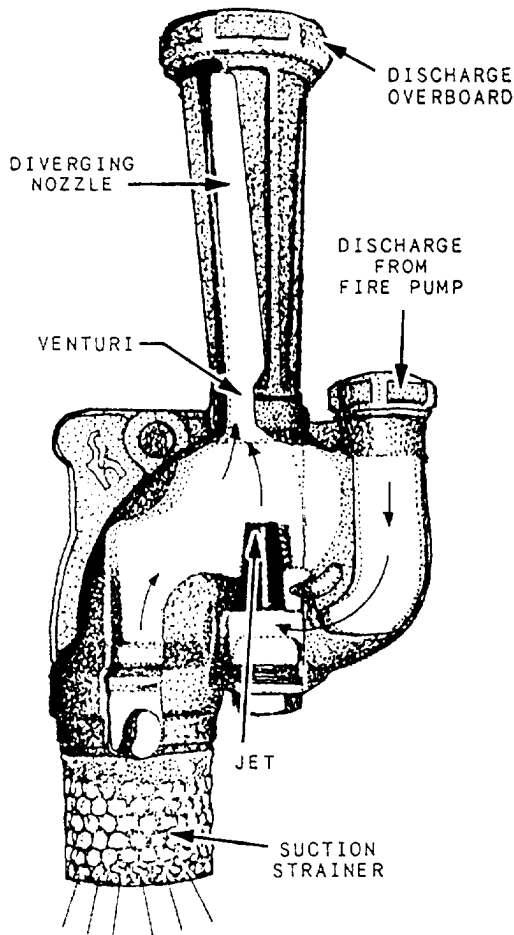

Figure 9-13.—Eductor.

### Jet Pumps

The pumps discussed so far in this chapter have had a variety of moving parts. One type of pump you find in the engine room is the jet pump, usually called an eductor. Figure 9-13 shows an eductor, which has no moving parts. These pumps are used for pumping large quantities of water overboard in such applications as pumping bilges and dewatering compartments. As an engineer, you will think of eductors as part of the main and secondary drainage system; you will also become familiar with them as part of the ship's damage control equipment.

Eductors use a high-velocity jet of seawater to lower the pressure in the chamber around the converging nozzle. Seawater is supplied to the converging nozzle at a relatively low velocity and exits the nozzle at a high velocity. As the seawater leaves the nozzle and passes through the chamber,

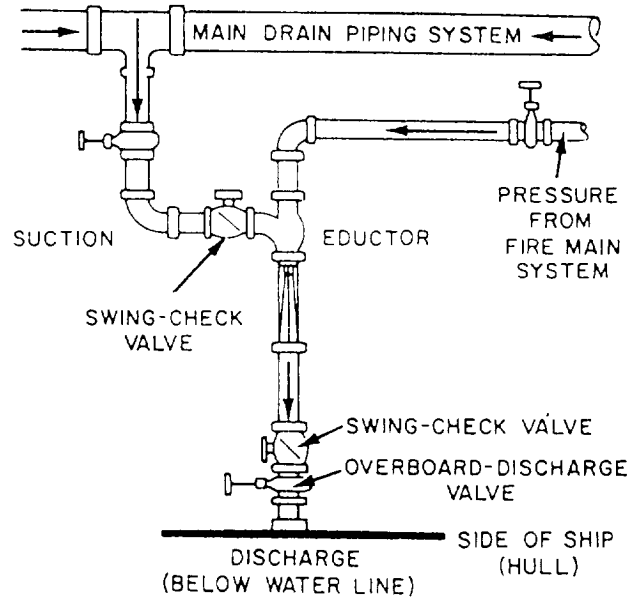

Figure 9-14.—Typical eductor system.

air becomes entrained in the jet stream and is pumped out of the chamber. Pressure in the chamber decreases, allowing atmospheric pressure to push the surrounding water into the chamber and mix with the jet stream. The diverging nozzle allows the velocity of the fluid to decrease and the pressure to increase; the discharge pressure is then established.

Figure 9-14 is an example of a typical shipboard eductor system. Note that the eductor discharge piping is below the water line. The swing-check valve above the overboard-discharge valve prevents water from backing up into the system if the system pressure drops below the outside water pressure. To prevent engineering spaces from flooding, you must follow the step-by-step procedures that are posted next to eductor stations.

### ALIGNMENT OF SHAFT AND COUPLING

When you install or assemble pumps driven by electric motors, make sure the unit is aligned properly. If the shaft is misaligned, you must realign the unit to prevent shaft breakage and damage to bearings, pump casing wearing rings, and throat bushings. Always check the shaft alignment with all the piping in place.

Some driving units are connected to the pump by a FLEXIBLE COUPLING. A flexible coupling



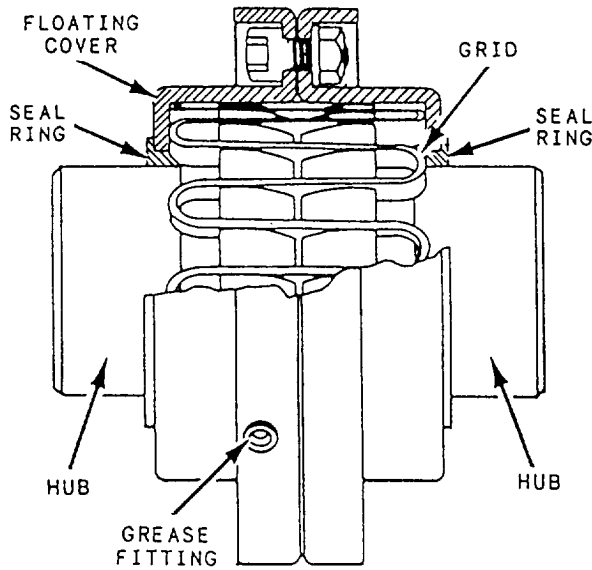

Figure 9-15.—Grid-type flexible coupling.

(fig. 9-15) is intended to take care of only a slight misalignment. Misalignment should never exceed the amount specified by the pump manufacturer. If the misalignment is excessive, the coupling parts are subjected to severe punishment, necessitating frequent replacement of pins, bushings, and bearings. It is absolutely necessary to have the

rotating shafts of the driver and driven units in proper alignment. Figure 9-16 shows coupling alignment.

You should check the shaft alignment when the pump is opened for repair or maintenance, or if a noticeable vibration occurs. You must realign the unit if the shafts are out of line or inclined at an angle to each other. Whenever practicable, check the alignment with all piping in place and with the adjacent tanks and piping filled.

When the driving unit is connected to the pump by a FLANGE COUPLING, the shafting may require frequent realignment, which may be indicated by high temperatures, noises, and worn bearings or bushings.

Wedges, or shims, are sometimes placed under the bases of both the driven and driving units (fig. 9-16, view A) for ease in alignment when the machinery is installed. When the wedges or other packing have been adjusted so the outside diameters and faces of the coupling flanges run true as they are manually revolved, the chocks are fastened, the units are securely bolted to the foundation, and the coupling flanges are bolted together.

The faces of the coupling flanges should be checked at 90-degree intervals. This method is shown in figure 9-16, view B. Find the distances between the faces at point a, point b (on the

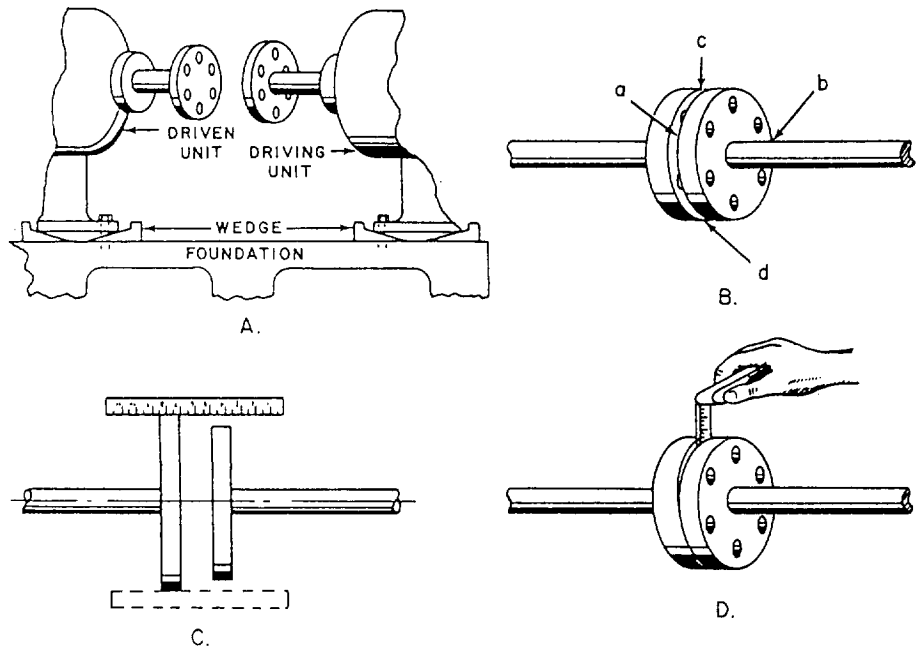

Figure 9-16.—Coupling alignment.

opposite side), point c, and point d (opposite point c). This action will show whether the coupling faces are parallel to each other. If they are not parallel to each other, adjust the driving unit or the pump with shims until the couplings check true. While measuring the distances, you must keep the outside diameters of the coupling flanges in line. To do this, place the scale across the two flanges, as shown in figure 9-16, view C. If the flanges do not line up, raise or lower one of the units with shims, or shift them sideways.

The procedure for using a thickness gauge to check alignments is similar to that for a scale. When the outside diameters of the coupling flanges are not the same, use a scale on the

surface of the larger flange, and then use a thickness gauge between the surface of the smaller flange and the edge of the scale. When the space is narrow, check the distance between the coupling flanges with a thickness gauge, as shown in figure 9-16, view D. Check wider spaces with a piece of square key stock and a thickness gauge.

### CONSTANT-PRESSURE PUMP GOVERNORS

A governor is a feedback device that is used to provide automatic control of speed, pressure, or temperature. A constant-pressure pump

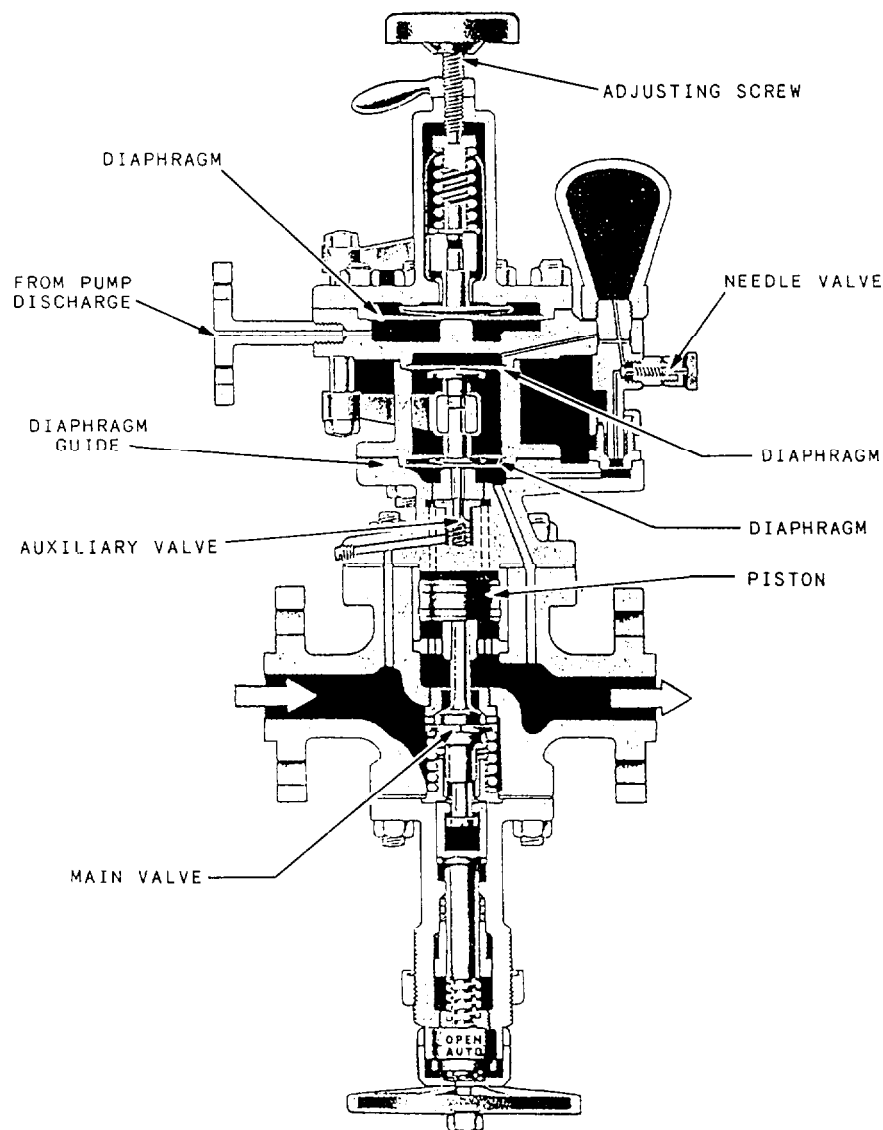

Figure 9-17.—Constant-pressure pump governor.

governor maintains a constant discharge pressure, regardless of pump capacity or output. Most constant-pressure pump governors used in the Navy control steam-driven pumps, both rotary and centrifugal types.

The constant-pressure pump governor (sometimes referred to as pressure-regulating) consists essentially of an automatic throttling valve installed in the steam supply line to the pump's driving unit. A pipeline connects the governor to the pump's discharge line. Variations in discharge pressure, or in pressure differential, actuate the governor, causing it to regulate the pump speed by varying the flow of steam to the driving unit.

A constant-pressure pump governor for a lubricating oil service pump is shown in figure 9-17. The governors used on fuel oil service pumps and on main feed pumps are of the same type. The size of the upper diaphragm and the amount of spring tension vary on governors used for different services. You will find detailed information concerning the operation and adjustment of governors in chapter 503 of the *NSTM*.

## VALVES

A valve is any device used to control fluids in a closed system. In this section we will discuss valve construction and the most common types of valves you will use in the day-to-day operation and maintenance of the various shipboard engineering systems. Valves are typed or classified according to their use in a system.

### VALVE CONSTRUCTION

Valves are usually made of bronze, brass, cast or malleable iron, or steel. Steel valves are either cast or forged and are made of either plain steel or alloy steel. Alloy steel valves are used in high-pressure, high-temperature systems; the disks and seats (internal sealing surfaces) of these valves are usually surfaced with a chromium-cobalt alloy known as Stellite. Stellite is extremely hard.

Brass and bronze valves are never used in systems where temperatures exceed 550°F. Steel

valves are used for all services above 550°F and in lower temperature systems where internal or external conditions of high pressure, vibration, or shock would be too severe for valves made of brass or bronze. Bronze valves are used almost exclusively in systems that carry salt water. The seats and disks of these valves are usually made of Monel, a metal that has excellent corrosion- and erosion-resistant qualities.

Most submarine seawater valves are made of an alloy of 70 percent copper to 30 percent nickel (70/30).

### VALVE TYPES

Although many different types of valves are used to control the flow of fluids, the basic valve types can be divided into two general groups: stop valves and check valves.

Besides the basic types of valves, many special valves, which cannot really be classified as either stop valves or check valves, are found in the engineering spaces. Many of these valves serve to control the pressure of fluids and are known as pressure-control valves. Other valves are identified by names that indicate their general function, such as thermostatic recirculating valves. The following sections deal first with the basic types of stop valves and check valves, then with some of the more complicated special valves.

#### Stop Valves

Stop valves are used to shut off or, in some cases, partially shut off the flow of fluid. Stop valves are controlled by the movement of the valve stem. Stop valves can be divided into four general categories: globe, gate, butterfly, and ball valves. Plug valves and needle valves may also be considered stop valves.

**GLOBE VALVES.**—Globe valves are probably the most common valves in existence. The globe valve derives its name from the globular shape of the valve body. However, positive identification of a globe valve must be made internally because other valve types may have globular appearing bodies. Globe valve inlet and outlet openings are arranged in several ways to suit varying

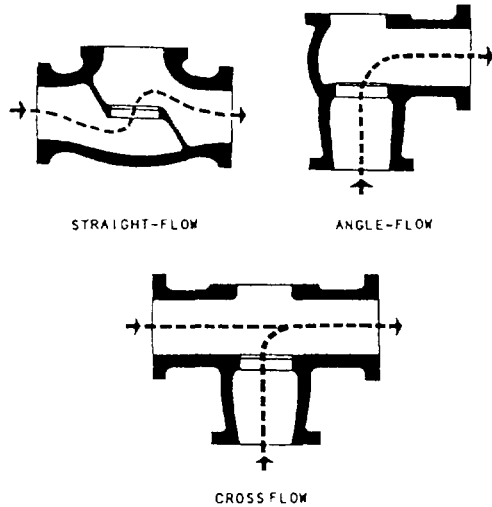

Figure 9-18.—Types of globe valve bodies.

requirements of flow. Figure 9-18 shows the common types of globe valve bodies: straight-flow, angle-flow, and cross flow. Globe valves are used extensively throughout the engineering plant and other parts of the ship in a variety of systems.

**GATE VALVES.**— Gate valves are used when a straight-line flow of fluid and minimum restriction is desired. Gate valves are so named because the part that either stops or allows flow through the valve acts somewhat like the opening or closing of a gate and is called, appropriately, the gate. The gate is usually wedge shaped. When the valve is wide open, the gate is fully drawn up into the valve, leaving an opening for flow through the valve the same size as the pipe in which the valve is installed. Therefore, there is little pressure drop or flow restriction through the valve. Gate valves are not suitable for throttling purposes since the control of flow would be difficult due to valve design and since the flow of fluid slapping against a partially open gate can cause extensive damage to the valve. Except as specifically authorized, gate valves should not be used for throttling.

Gate valves are classified as either **RISING-STEM** or **NONRISING-STEM** valves. On the nonrising-stem gate valve shown in figure 9-19, the stem is threaded on the lower end into the gate. As the handwheel on the stem is rotated, the gate travels up or down the stem on the threads, while the stem remains vertically stationary. This type of valve almost always has a pointer-type indicator

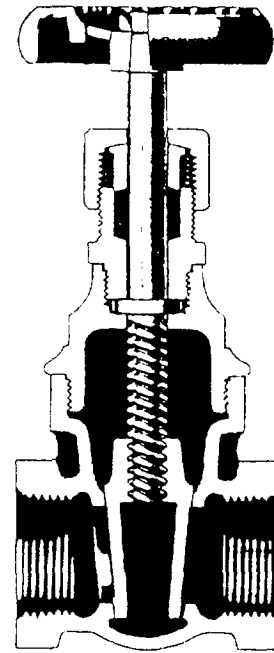

Figure 9-19.—Cutaway view of a gate valve (nonrising-stem type).

threaded onto the upper end of the stem to indicate valve position.

The rising-stem gate valve, shown in figure 9-20, has the stem attached to the gate; the gate and stem rise and lower together as the valve is operated.

Gate valves used in steam systems have flexible gates. The reason for using a flexible gate is to prevent binding of the gate within the valve when the valve is in the closed position. When steam lines are heated, they will expand, causing some distortion of valve bodies. If a solid gate fits snugly between the seat of a valve in a cold steam system, when the system is heated and pipes elongate, the seats will compress against the gate, wedging the gate between them and clamping the valve shut. This problem is overcome by use of a flexible gate (two circular plates attached to each other with a flexible hub in the middle). This design allows the gate to flex as the valve seat compresses it, thereby preventing clamping.

**BUTTERFLY VALVES.**— The butterfly valve, one type of which is shown in figure 9-21, may be used in a variety of systems aboard ship. These valves can be used effectively in freshwater, saltwater, JP-5, F-76 (naval distillate), lube oil, and chill water systems aboard ship. The butterfly valve is light in weight, relatively small, relatively

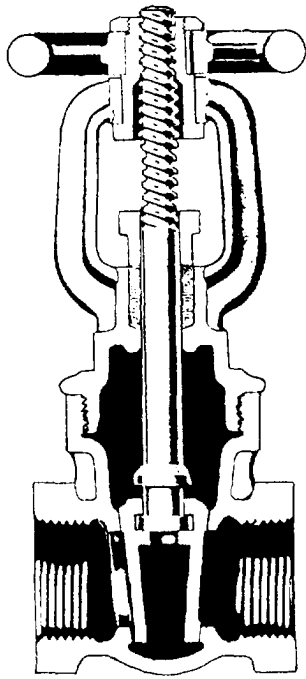

Figure 9-20.—Cutaway view of a gate valve (rising-stem type).

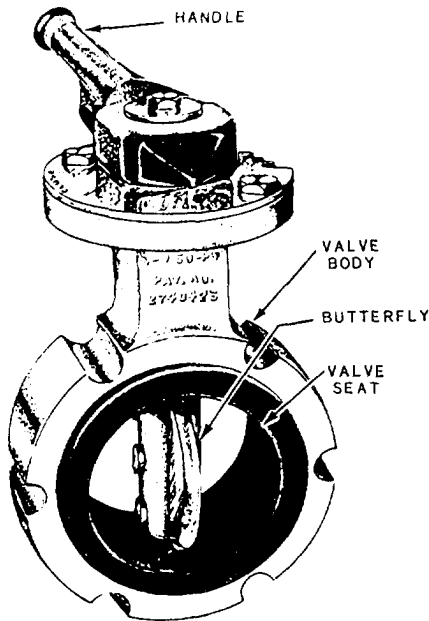

Figure 9-21.—Butterfly valve.

quick-acting, provides positive shut-off, and can be used for throttling.

The butterfly valve has a body, a resilient seat, a butterfly disk, a stem, packing, a notched positioning plate, and a handle. The resilient seat

is under compression when it is mounted in the valve body, thus making a seal around the periphery of the disk and both upper and lower points where the stem passes through the seat. Packing is provided to form a positive seal around the stem for added protection in case the seal formed by the seat should become damaged.

To close or open a butterfly valve, turn the handle only one quarter turn to rotate the disk 90°. Some larger butterfly valves may have a handwheel that operates through a gearing arrangement to operate the valve. This method is used especially where space limitation prevents use of a long handle.

Butterfly valves are relatively easy to maintain. The resilient seat is held in place by mechanical means, and neither bonding nor cementing is necessary. Because the seat is replaceable, the valve seat does not require lapping, grinding, or machine work.

**BALL VALVES.**— Ball valves, as the name implies, are stop valves that use a ball to stop or start the flow of fluid. The ball (fig. 9-22) performs the same function as the disk in the globe valve. When the valve handle is operated to open the valve, the ball rotates to a point where the hole through the ball is in line with the valve body inlet and outlet. When the valve is shut, which requires only a 90-degree rotation of the handwheel for most valves, the ball is rotated so

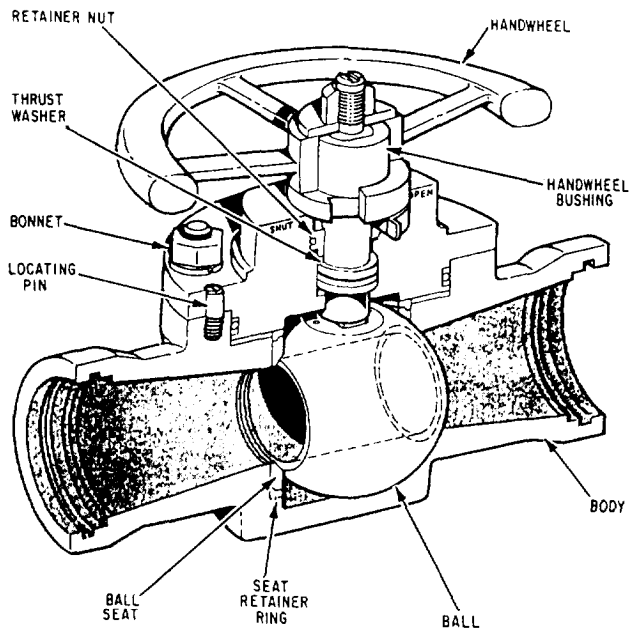

Figure 9-22.—Typical seawater ball valve.

the hole is perpendicular to the flow openings of the valve body, and flow is stopped.

Most ball valves are of the quick-acting type (requiring only a 90-degree turn to operate the valve either completely open or closed), but many are planetary gear operated. This type of gearing allows the use of a relatively small handwheel and operating force to operate a fairly large valve. The gearing does, however, increase the operating time for the valve. Some ball valves contain a swing check located within the ball to give the valve a check valve feature. Ball valves are normally found in the following systems aboard ship: seawater, sanitary, trim and drain, air, hydraulic, and oil transfer.

### Check Valves

Check valves are used to allow fluid flow in a system in only one direction. They are operated by the flow of fluid in the piping. A check valve may be the swing type, lift type, or ball type.

As we have seen, most valves can be classified as being either stop valves or check valves. Some

valves, however, function either as stop valves or as check valves—depending on the position of the valve stem. These valves are known as STOP-CHECK VALVES.

A stop-check valve is shown in cross section in figure 9-23. This type of valve looks very much like a lift-check valve. However, the valve stem is long enough so when it is screwed all the way down it holds the disk firmly against the seat, thus preventing any flow of fluid. In this position, the valve acts as a stop valve. When the stem is raised, the disk can be opened by pressure on the inlet side. In this position, the valve acts as a check valve, allowing the flow of fluid in only one direction. The maximum lift of the disk is controlled by the position of the valve stem. Therefore, the position of the valve stem limits the amount of fluid passing through the valve even when the valve is operating as a check valve.

Stop-check valves are widely used throughout the engineering plant. Stop-check valves are used in many drain lines and on the discharge side of many pumps.

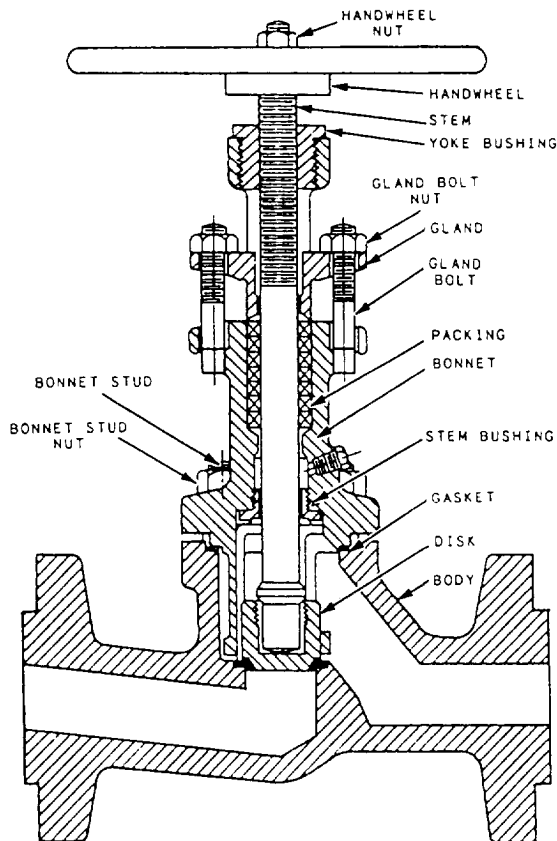

Figure 9-23.—Stop-check valve.

### Special-Purpose Valves

There are many types of automatic pressure control valves. Some of them merely provide an escape for pressures exceeding the normal pressure; some provide only for the reduction of pressure; and some provide for the regulation of pressure.

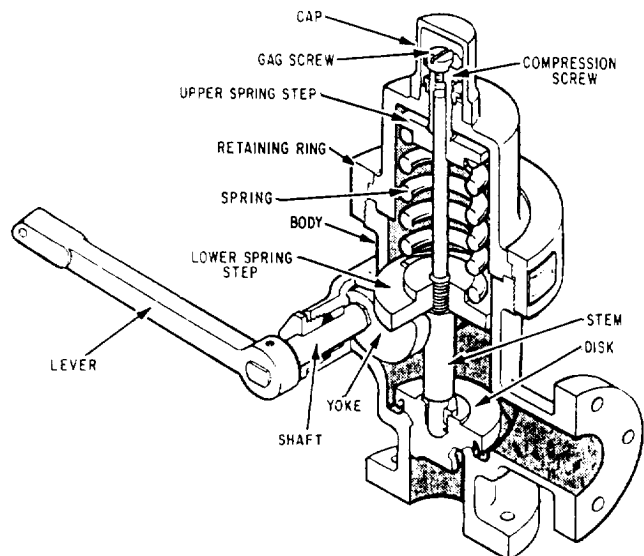

Figure 9-24.—Typical relief valve.

**RELIEF VALVES.**— Relief valves are automatic valves used on system lines and equipment to prevent overpressurization. Most relief valves simply lift (open) at a preset pressure and reset (shut) when the pressure drops only slightly below the lifting pressure. Figure 9-24 shows a relief valve of this type. System pressure simply acts under the valve disk at the inlet of the valve. When system pressure exceeds the force exerted by the valve spring, the valve disk lifts off its seat, allowing some of the system fluid to escape through the valve outlet until system pressure is reduced to just below the relief set point of the valve. The spring then reseats the valve. An operating lever is provided to allow manual cycling of the relief valve or to gag it open for certain tests. Virtually all relief valves are provided with some type of device to allow manual cycling.

Other types of relief valves are the high-pressure air safety relief valve and the bleed air surge relief valve. Both of these types of valves are designed to open completely at a specified lift pressure and to remain open until a specific reset pressure is reached—at which time they shut. Many different designs of these valves are used, but the same result is achieved.

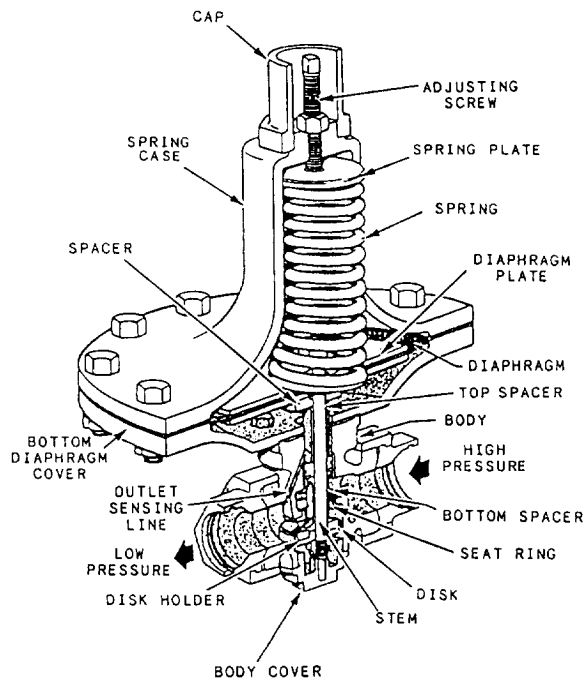

Figure 9-25.—Pressure-reducing (spring-loaded) valve.

**SPRING-LOADED REDUCING VALVES.**— Spring-loaded reducing valves, one type of which is shown in figure 9-25, are used in a wide variety of applications. Low-pressure air reducers and others are of this type. The valve simply uses spring pressure against a diaphragm to open the valve. On the bottom of the diaphragm, the outlet pressure (the pressure in the reduced pressure system) of the valve forces the disk upward to shut the valve. When the outlet pressure drops below the set point of the valve, the spring pressure overcomes the outlet pressure and forces the valve stem downward, opening the valve. As the outlet pressure increases, approaching the desired value, the pressure under the diaphragm begins to overcome spring pressure, forcing the valve stem upwards, shutting the valve. You can adjust the downstream pressure by removing the valve cap and turning the adjusting screw, which varies the spring pressure against the diaphragm. This particular spring-loaded valve will fail in the open position if a diaphragm rupture occurs.

**REMOTE-OPERATING VALVES.**— Remote-operating gear is installed to provide a means of operating certain valves from distant stations. Remote-operating gear may be mechanical, hydraulic, pneumatic, or electric.

Some remote-operating gear for valves is used in the normal operation of valves. For example, the main drain system manual valves are opened and closed by a reach rod or a series of reach rods and gears. Reach rods may be used to operate engine-room valves in instances where the valves are difficult to reach from the operating stations.

Other remote-operating gear is installed as emergency equipment. Some of the main drain and almost all of the secondary drain system valves are equipped with remote-operating gears. You can operate these valves locally, or in an emergency, you can operate them from remote stations. Remote-operating gear also includes a valve position indicator to show whether the valve is open or closed.

**PRESSURE-REDUCING VALVES.**— Pressure-reducing valves are automatic valves that provide a steady pressure into a system that is at a lower pressure than the supply system. Reducing valves of one type or another are found, for example, in firemain, seawater, and other systems. A reducing valve can normally be set for any desired downstream pressure within the design limits of the valve. Once the valve is set, the reduced pressure will be maintained regardless of changes

in the supply pressure (as long as the supply pressure is at least as high as the reduced pressure desired) and regardless of the amount of reduced pressure fluid that is used.

Various designs of pressure-reducing valves are in use. Two of the types most commonly found on gas turbine ships are the spring-loaded reducing valve (already discussed) and the air-pilot operated diaphragm reducing valve.

Air-pilot operated diaphragm control valves are used extensively on naval ships. The valves and pilots are available in several designs to meet different requirements. They may be used to reduce pressure, to increase pressure, as unloading valves, or to provide continuous regulation of pressure. Valves and pilots of very similar design can also be used for other services, such as liquid-level control and temperature control.

The air-operated control pilot may be either direct acting or reverse acting. A direct-acting, air-operated control pilot is shown in figure 9-26. In this type of pilot, the controlled pressure—that is, the pressure from the discharge side of the diaphragm control valve—acts on top of a diaphragm in the control pilot. This pressure is balanced by the pressure exerted by the pilot adjusting spring. If the controlled pressure increases and overcomes the pressure exerted by the pilot adjusting spring, the pilot valve stem is forced downward. This action causes the pilot valve to open, thereby increasing the amount of operating air pressure going from the pilot to the diaphragm control valve. A reverse-acting pilot has a lever that reverses the pilot action. In a reverse-acting pilot, therefore, an increase in controlled pressure produces a decrease in operating air pressure.

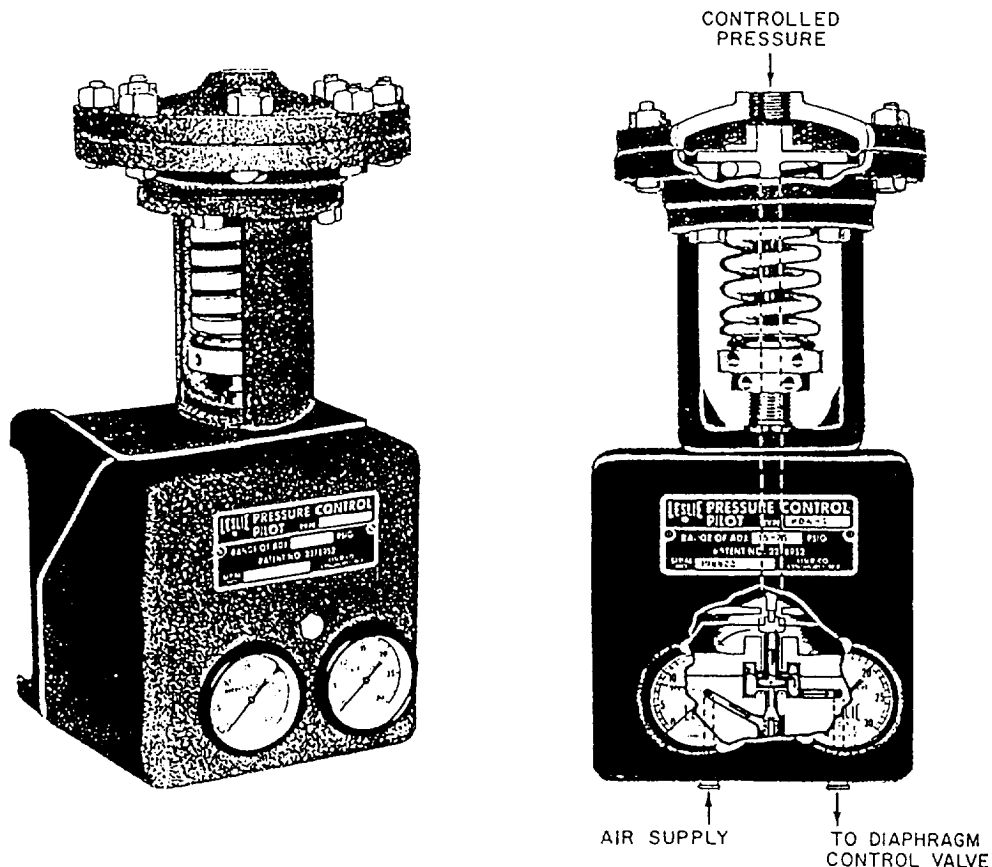
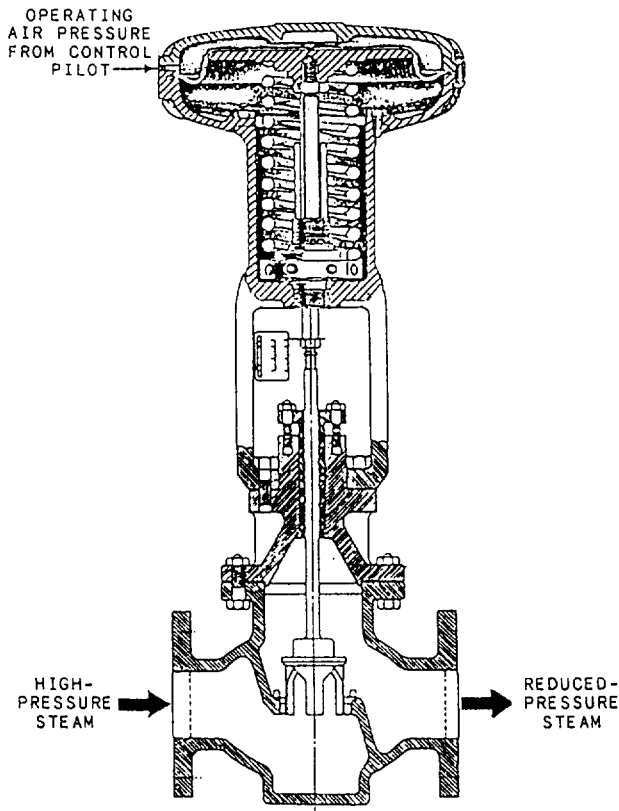

Figure 9-26.—Air-operated control pilot.



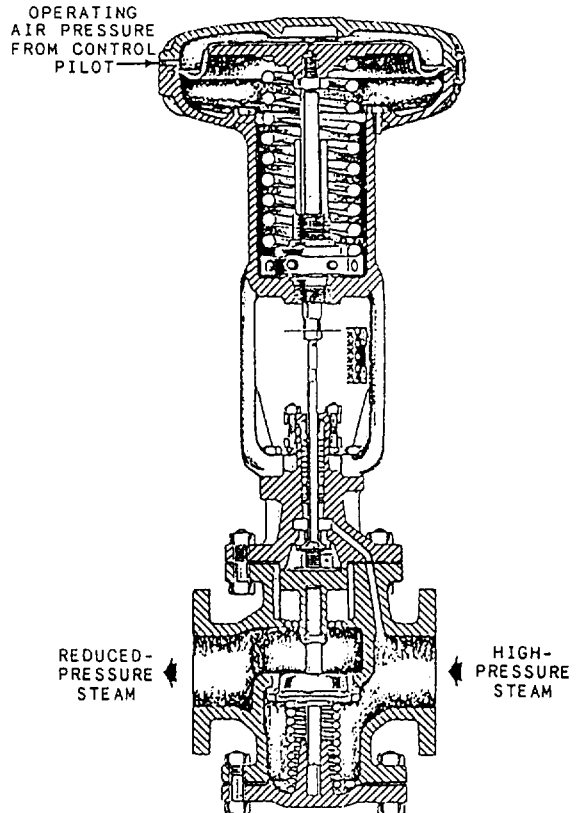

**Figure 9-27.—Diaphragm control valve, downward-seating type.**

In the diaphragm control valve, operating air from the pilot acts on the valve diaphragm. The superstructure, which contains the diaphragm, is direct acting in some valves and reverse acting in others. If the superstructure is direct-acting, the operating air pressure from the control pilot is applied to the TOP of the valve diaphragm. If the superstructure is reverse-acting, the operating air pressure from the pilot is applied to the UNDERSIDE of the valve diaphragm.

Figure 9-27 shows a very simple type of direct-acting diaphragm control valve with operating air pressure from the control pilot applied to the top of the valve diaphragm. Since the valve in the figure is a downward-seating valve, any increase in operating air pressure pushes the valve stem downward toward the closed position.

Now look at figure 9-28. This is also a direct-acting valve with operating air pressure from the control pilot applied to the top of the valve



**Figure 9-28.—Diaphragm control valve, upward-seating type.**

diaphragm. Note that the valve shown in figure 9-28 is more complicated than the one shown in figure 9-27 because of the added springs under the seat. The valve shown in figure 9-28 is an upward-seating valve rather than a downward-seating valve. Therefore, any increase in operating air pressure from the control pilot tends to OPEN this valve rather than to close it.

As you have seen, the air-operated control pilot may be either direct acting or reverse acting. The superstructure of the diaphragm control valve may be either direct acting or reverse acting. And, the diaphragm control valve may be either upward seating or downward seating. These three factors, as well as the purpose of the installation, determine how the diaphragm control valve and its air-operated control pilot are installed in relation to each other.

To see how these factors are related, let's consider an installation in which a diaphragm control valve and its air-operated control pilot are used to supply controlled steam pressure.

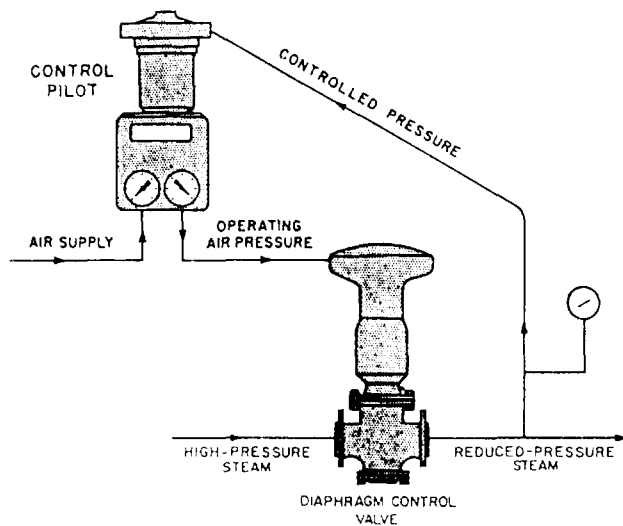
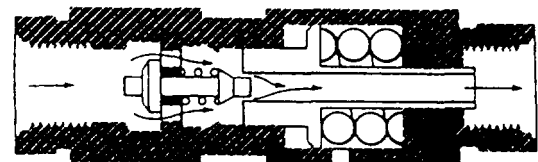

Figure 9-29.—Arrangement of control pilot and diaphragm control valve for supplying reduced-steam pressure.

Figure 9-29 shows one arrangement that you might use. Assume that the service requirements indicate the need for a direct-acting, upward-seating diaphragm control valve. Can you figure out which kind of a control pilot—direct acting or reverse acting—should be used in this installation?

Try it first with a direct-acting control pilot. As the controlled pressure (discharge pressure from the diaphragm control valve) increases, increased pressure is applied to the diaphragm of the direct-acting control pilot. The valve stem is pushed downward and the valve in the control pilot is opened. This increases the operating air pressure from the control pilot to the top of the diaphragm control valve. The increased operating air pressure acting on the diaphragm of the valve pushes the stem downward, and since this is an upward-seating valve, this action **OPENS** the diaphragm control valve still wider. Obviously, this won't work for this application. An **INCREASE** in controlled pressure must result in a **DECREASE** in operating air pressure. Therefore, we made a mistake in choosing the direct-acting control pilot. For this particular pressure-reducing application, you should choose a **REVERSE-ACTING** control pilot.

It is not likely that you will be required to decide which type of control pilot and diaphragm control valve is needed in any particular installation. But you must know how and why they are selected so you do not make mistakes in repairing or replacing these units.



A. PRIORITY FLOW

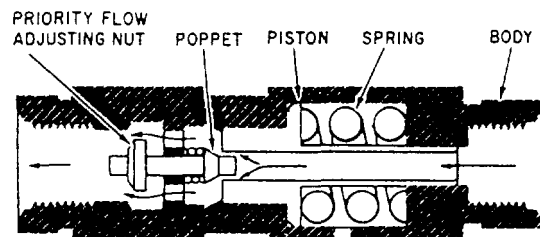

B. FREE FLOW

Figure 9-30.—Priority valve.

**PRIORITY VALVES.**— In systems with two or more circuits, it is sometimes necessary to have some means of supplying all available fluid to one particular circuit in case of a pressure drop in the system. A priority valve is often incorporated in the system to ensure a supply of fluid to the critical/vital circuit. The components of the system are arranged so the fluid to operate each circuit, except the one critical/vital circuit, must flow through the priority valve. A priority valve may also be used within a subsystem containing two or more actuating units to ensure a supply of fluid to one of the actuating units. In this case, the priority valve is incorporated in the subsystem in such a location that the fluid to each actuating unit, except the critical/vital unit, must flow through the valve.

Figure 9-30 shows one type of priority valve. View A of figure 9-30 shows the valve in the priority-flow position; that is, the fluid must flow through the valve in the direction shown by the arrows to get to the noncritical/vital circuits or actuating units. With no fluid pressure in the valve, spring tension forces the piston against the stop and the poppet seats against the hole in the center of the piston. As fluid pressure increases, the spring compresses and the piston moves to the right. The poppet follows the piston, sealing the hole in the center of the piston until the preset pressure is reached. (The preset pressure depends upon the requirements of the system and is set by the manufacturer.) Assume that the critical/vital circuit or actuating unit requires 1500 psi.

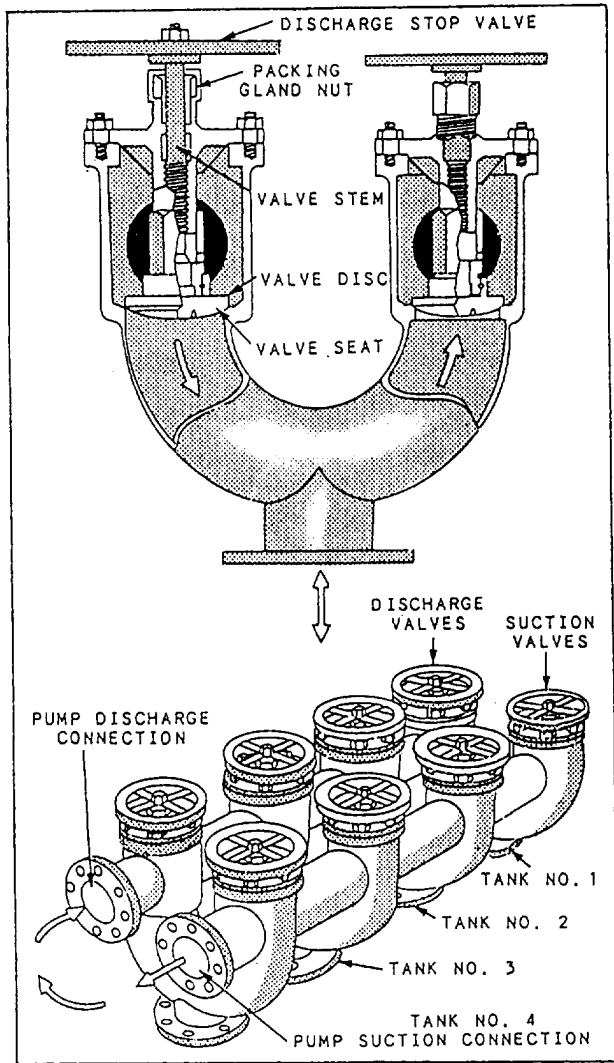

Figure 9-31.—Valve manifold showing cutaway view of the valves and typical combination of suction and discharge valves.

When the pressure in the valve reaches 1500 psi, the poppet reaches the end of its travel. As the pressure increases, the piston continues to move to the right, which unseats the poppet and allows flow through the valve, as shown in view A of figure 9-30. If the pressure drops below 1500 psi, the compressed spring forces the piston to the left, the poppet seats, and flow through the valve stops.

Figure 9-30, view B, shows the priority valve in the free-flow position. The flow of fluid moves the poppet to the left, the poppet spring compresses, and the poppet unseats. This allows free flow of fluid through the valve.

## VALVE MANIFOLDS

Sometimes suction must be taken from one of many sources and discharged to another unit or units of either the same or another group. A valve manifold is used for this type of operation. An example of such a manifold (fig. 9-31) is the fuel oil filling and transfer system where provision must be made for the transfer of oil from any tank to any other tank, to the service system, or to another ship. If, for example, the purpose is to transfer oil from tank No. 1 to tank No. 4, the discharge valve for tank No. 4 and the suction valve from tank No. 1 are opened, and all other valves are closed. Fuel oil can now flow from tank No. 1, through the suction line, through the pump, through the discharge valve, and into tank No. 4. The manifold suction valves are often of the stop-check type to prevent draining of pumps when they are stopped.

## VALVE HANDWHEEL IDENTIFICATION AND COLOR CODING

Valves are identified by markings inscribed on the rims of the handwheels, by a circular label plate secured by the handwheel nut, or by label plates attached to the ship's structure or to the adjacent piping.

Piping system valve handwheels and operating levers are marked for training and casualty control purposes with a standardized color code. Color code identification is in conformance with the color scheme of table 9-1. Implementation of

Table 9-1.—Valve Handwheel Color Code

FLUID	VALVE HANDWHEEL & OPERATING LEVER
STEAM.....	WHITE
POTABLE-WATER.....	DARK BLUE
NITROGEN.....	LIGHT GRAY
HP AIR.....	DARK GRAY
LP AIR.....	TAN
OXYGEN.....	LIGHT GREEN
SALT WATER.....	DARK GREEN
JP-5.....	PURPLE
FUEL OIL.....	YELLOW
LUBE OIL.....	STRIPED YELLOW/BLACK
FIRE PLUGS.....	RED
FOAM DISCHARGE.....	STRIPED RED/GREEN
GASOLINE.....	YELLOW
FEEDWATER.....	LIGHT BLUE
HYDRAULIC.....	ORANGE
HYDROGEN.....	CHARTREUSE
HELIUM.....	BUFF
HELIUM/OXYGEN.....	STRIPED BUFF/GREEN
SEWAGE.....	GOLD

this color scheme provides uniformity among all naval surface ships and shore-based training facilities.

## MAINTENANCE

Preventive maintenance is the best way to extend the life of valves and fittings. Always refer to the applicable portion of the *Standard Navy Valve Technical Manual*, NAVSEA 0948-LP-012-5000, if possible. When making repairs on more sophisticated valve types, use the available manufacturer's technical manuals. As soon as you observe a leak, determine the cause, and then apply the proper corrective maintenance. Maintenance may be as simple as tightening a packing nut or gland. A leaking flange joint may need only to have the bolts tightened or to have a new gasket or O-ring inserted. Dirt and scale, if allowed to collect, will cause leakage. Loose hangers permit sections of a line to sag, and the weight of the pipe and the fluid in these sagging sections may strain joints to the point of leakage.

Whenever you are going to install a valve, be sure you know the function the valve is going to perform—that is, whether it must start flow, stop flow, regulate flow, regulate pressure, or prevent backflow. Inspect the valve body for the information that is stamped upon it by the manufacturer: type of system (oil, water, gas), operating pressure, direction of flow, and other information.

You should also know the operating characteristics of the valve, the metal from which it is made, and the type of end connection with which it is fitted. Operating characteristics and the material are factors that affect the length and kind of service that a valve will give; end connections indicate whether or not a particular valve is suited to the installation.

When you install valves, ensure they are readily accessible and allow enough headroom for full operation. Install valves with stems pointing upward if possible. A stem position between straight up and horizontal is acceptable, but avoid the inverted position (stem pointing downward). If the valve is installed with the stem pointing downward, sediment will collect in the bonnet and score the stem. Also, in a line that is subject to freezing temperatures, liquid that is trapped in the valve bonnet may freeze and rupture it.

Since you can install a globe valve with pressure either above the disk or below the disk (depending on which method will be best for the operation, protection, maintenance, and repair of

the machinery served by the system), you should use caution. The question of what would happen if the disk became detached from the stem is a major consideration in determining whether pressure should be above the disk or below it. If you are required to install a globe valve, be SURE to check the blueprints for the system to see which way the valve must be installed. Very serious casualties can result if a valve is installed with pressure above the disk when it should be below the disk, or below the disk when it should be above.

Valves that have been in constant service for a long time will eventually require gland tightening, repacking, or a complete overhaul of all parts. If you know that a valve is not doing the job for which it was intended, dismantle the valve and inspect all parts. You must repair or replace all defective parts.

The repair of globe valves (other than routine renewal of packing) is limited to refinishing the seat and/or disk surface. When doing this work, you should observe the following precautions:

- When refinishing the valve seat, do not remove more material than is necessary. You can finish valves that do not have replaceable valve seats only a limited number of times.
- Before doing any repair to the seat and disk of a globe valve, check the valve disk to make certain it is secured rigidly to and is square on the valve stem. Also, check to be sure that the stem is straight. If the stem is not straight, the valve disk cannot seat properly.
- Carefully inspect the valve seat and valve disk for evidence of wear, for cuts on the seating area, and for improper fit of the disk to the seat. Even if the disk and seat appear to be in good condition, you should perform a spot-in check to find out whether they actually are in good condition.

Figure 9-32 shows a standard checkoff diagram for performing a routine inspection and minor maintenance of a valve.

### Spotting-In Valves

The method used to visually determine whether the seat and the disk of a valve make good contact with each other is called spotting-in. To

1. STEM & STEM THREADS—REMOVE BURRS AND PAINT. CLEAN WITH RAGS OR CROCUS CLOTH, DO NOT PAINT.

2. STRONGBACK/PACKING RETAINER—CLEAN WITH WIRE BRUSH AND USE A LIGHT SILICONE SPRAY LUBRICANT.

3. GLAND—CLEAN WITH RAGS OR CROCUS CLOTH, DO NOT PAINT, (INTERNAL).

4. VALVE BONNET—CLEAN WITH WIRE BRUSH; PAINT.

5. VALVE BODY\*—CLEAN WITH WIRE BRUSH; PAINT.

6. VALVE DISK—INSPECT FOR CUTS, CRACKS AND REPORT ANY ABNORMALITIES TO THE CPO AS THIS COMPONENT OR PART IS VITAL FOR THE SAFE AND PROPER OPERATION OF A SYSTEM. BLUE THE DISK AND CHECK SEAT FOR PROPER SEATING SURFACE.

7. VALVE SEAT—INSPECT FOR CUTS, AND CRACKS AND REPORT ANY ABNORMALITIES TO THE CPO AS THIS PARTICULAR COMPONENT OR PART IS ALSO VITAL FOR SAFE AND PROPER OPERATION OF A SYSTEM.

8. VALVE IDENTIFICATION TAG—ENSURE TAG IS READABLE. REPLACE WHEN REASSEMBLING.

9. VALVE HANDWHEEL—CLEAN WITH A WIRE BRUSH; DO NOT PAINT.

10. STEM BUSHING—CLEAN WITH WIRE BRUSH; DO NOT PAINT.

11. YOKE—CLEAN WITH WIRE BRUSH; PAINT.

12. GLAND STUD—ENSURE AT LEAST ONE BUT NOT MORE THAN FOUR THREADS VISIBLE; CLEAN WITH WIRE BRUSH; DO NOT PAINT.

13. GLAND STUD NUT—CLEAN WITH WIRE BRUSH; ENSURE NUT "RUNS" FREELY ON GLAND STUD; PRESERVE WITH A LIGHT SILICONE LUBRICANT.

14. BODY-BONNET STUD—ENSURE AT LEAST ONE BUT NOT MORE THAN FOUR THREADS VISIBLE; CLEAN WITH WIRE BRUSH; DO NOT PAINT.

15. BODY-BONNET STUD NUT—CLEAN WITH WIRE BRUSH; PAINT.

16. GLAND STUFFING BOX—USE CORRECT STYLE SIZE AND ENSURE PACKING IS CUT PROPERLY. THE STYLE REFERS TO SERVICE OF VALVE AND TEMPERATURE OF LIQUID.

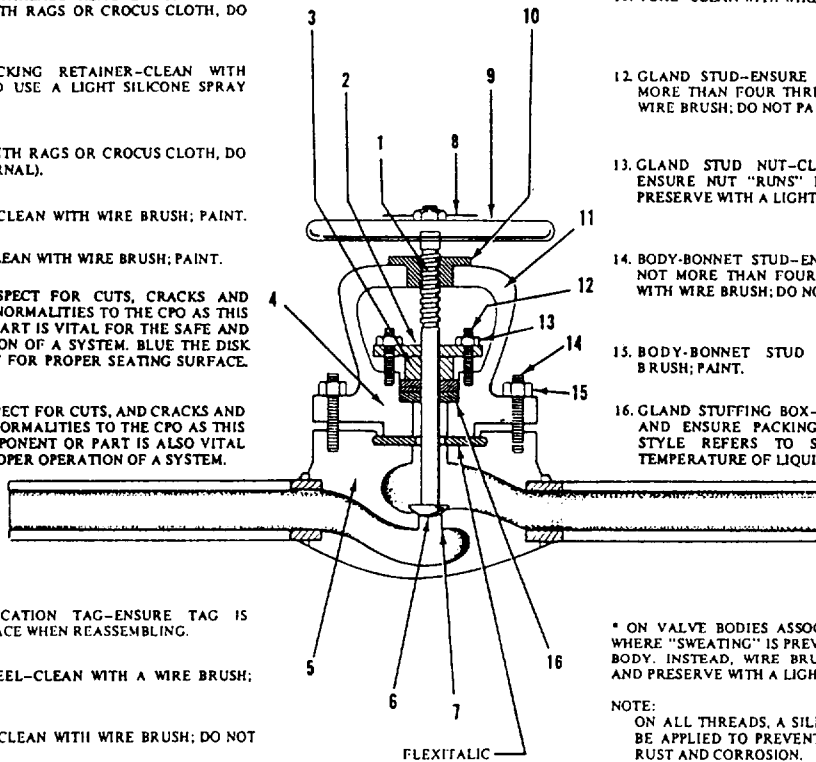

\* ON VALVE BODIES ASSOCIATED WITH S/W SYSTEMS WHERE "SWEATING" IS PREVELANT, DO NOT PAINT THE BODY. INSTEAD, WIRE BRUSH TO REMOVE VETIGRIS AND PRESERVE WITH A LIGHT SILICONE LUBRICANT.

NOTE:  
ON ALL THREADS, A SILICONE LUBRICANT SHOULD BE APPLIED TO PREVENT SEIZING AND TO RETARD RUST AND CORROSION.

Figure 9-32.—Valve maintenance checkoff diagram.

spot-in a valve seat, you first apply a thin coating of prussian blue (commonly called Blue Dykem) evenly over the entire machined face surface of the disk. Insert the disk into the valve and rotate it one-quarter turn, using a light downward pressure. The prussian blue will adhere to the valve seat at those points where the disk makes contact. Figure 9-33 shows the appearance of a correct seat when it is spotted-in; it also shows the appearance of various kinds of imperfect seats.

After you have noted the condition of the seat surface, wipe all the prussian blue off the disk face surface. Apply a thin, even coat of prussian blue to the contact face of the seat, place the disk on the valve seat again, and rotate the disk one-quarter turn. Examine the resulting blue ring on the valve disk. The ring should be unbroken and of uniform width. If the blue ring is broken in any way, the disk is not making proper contact with the seat.

### Grinding-In Valves

The manual process used to remove small irregularities by grinding together the contact

surfaces of the seat and disk is called grinding-in. Grinding-in should not be confused with refacing processes in which lathes, valve reseating machines, or power grinders are used to recondition the seating surfaces.

To grind-in a valve, first apply a light coating of grinding compound to the face of the disk. Then insert the disk into the valve and rotate the disk back and forth about one-quarter turn; shift

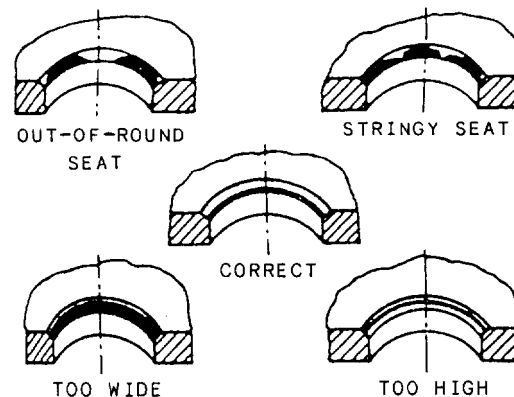

Figure 9-33.—Examples of spotted-in valve seats.

the disk-seat relationship from time to time so the disk will be moved gradually, in increments, through several rotations. During the grinding process, the grinding compound will gradually be displaced from between the seat and disk surfaces; therefore, you must stop every minute or so to replenish the compound. When you do this, wipe both the seat and the disk clean before applying the new compound to the disk face.

When you are satisfied that the irregularities have been removed, spot-in the disk to the seat in the manner previously described.

Grinding-in is also used to follow up all machining work on valve seats or disks. When the valve seat and disk are first spotted-in after they have been machined, the seat contact will be very narrow and will be located close to the bore. Grinding-in, using finer and finer compounds as the work progresses, causes the seat contact to become broader. The contact area should be a perfect ring covering about one-third of the seating surface.

Be careful to avoid overgrinding a valve seat or disk. Overgrinding will produce a groove in the seating surface of the disk; it will also round off the straight, angular surface of the disk. Machining is the only process by which overgrinding can be corrected.

### **Lapping Valves**

When a valve seat contains irregularities that are slightly larger than can be satisfactorily removed by grinding-in, the irregularities can be removed by lapping. A cast-iron tool (lap) of exactly the same size and shape as the valve disk is used to true the valve seat surface. The following are some precautions you should follow when lapping valves:

- Do not bear heavily on the handle of the lap.
- Do not bear sideways on the handle of the lap.
- Change the relationship between the lap and the valve seat occasionally so that the lap will gradually and slowly rotate around the entire seat circle.
- Keep a check on the working surface of the lap. If a groove develops, have the lap refaced.
- Always use clean compound for lapping.

- Replace the compound frequently.
- Spread the compound evenly and lightly.
- Do not lap more than is necessary to produce a smooth even seat.
- Always use a fine grinding compound to finish the lapping job.
- Upon completion of the lapping job, spot-in and grind-in the disk to the seat.

You should use only approved abrasive compounds for reconditioning valve seats and disks. Compounds for lapping valve disks and seats are supplied in various grades. Use a coarse grade compound when you find extensive corrosion or deep cuts and scratches on the disks and seats. Use a medium grade compound as a follow-up to the coarse grade; you may also use it to start the reconditioning process on valves that are not too severely damaged. Use a fine grade compound when the reconditioning process nears completion. Use a microscopic-fine grade for finish lapping and for all grinding-in.

### **Refacing Valves**

Badly scored valve seats must be refaced in a lathe, with a power grinder, or with a valve reseating machine. However, the lathe, rather than the reseating machine, should be used for refacing all valve disks and all hard-surfaced valve seats. Work that must be done on a lathe or with a power grinder should be turned over to shop personnel.

### **Repacking Valves**

If the stem and packing of a valve are in good condition, you can normally stop packing gland leaks by tightening up on the packing. You must be careful, however, to avoid excessive thread engagement of the packing gland studs (if used) and to avoid tightening old, hardened packing, which will cause the valve to seize. Subsequent operation of such a valve may score or bend the stem.

Coils, rings, and corrugated ribbon are the common forms of packing used in valves. The form of packing to be used in repacking a particular valve will depend on the valve size, application, and type. Packing materials will be discussed in more detail later in this chapter.

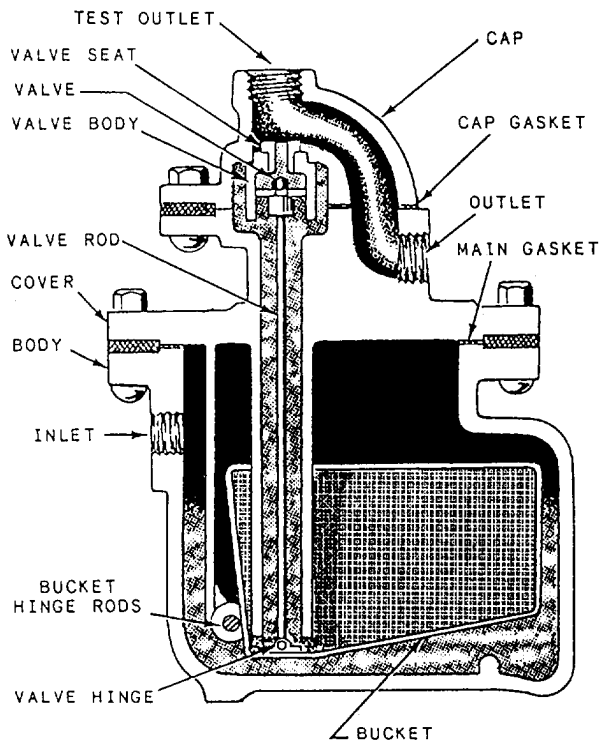

Figure 9-34.—Bucket-type steam trap.

### STEAM TRAPS

Steam traps are installed in steam lines to drain condensate from the lines without allowing the escape of steam. There are many different designs of steam traps; some are suitable for high-pressure use and others for low-pressure use.

#### TYPES OF STEAM TRAPS

Some types of steam traps that are used in the Navy are the mechanical steam traps, bimetallic steam traps, and orifice-type steam traps.

#### Mechanical Steam Traps

Mechanical steam traps in common use include bucket-type traps and ball-float traps.

The operation of the bucket-type steam trap, shown in figure 9-34, is controlled by the condensate level in the trap body. The bucket valve is connected to the bucket in such a way that the valve closes as the bucket rises. As condensate continues to flow into the trap body, the valve remains closed until the bucket is full. When the bucket is full, it sinks and thus opens the valve. The valve remains open until enough condensate has blown out to allow the bucket to float, thus closing the valve.

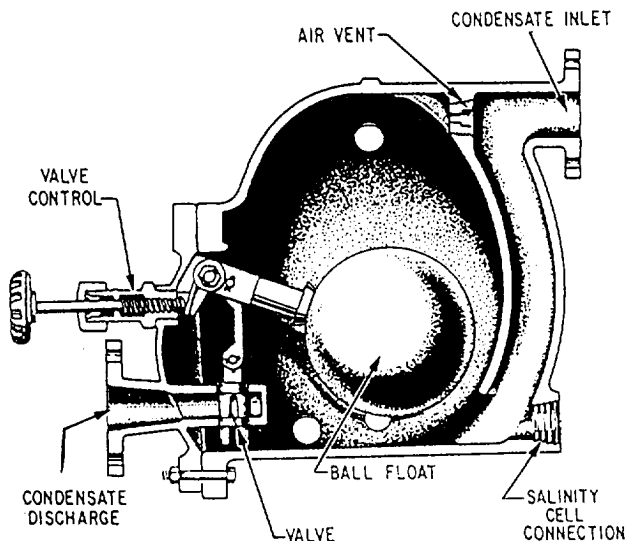

Figure 9-35.—Ball-float steam trap.

Figure 9-35 shows a ball-float steam trap. This trap works much in the same way as the bucket trap. Condensate and steam enter the body of the trap, and the condensate collects at the bottom. As the condensate level rises, the ball float rises until it is raised enough to open the outlet valve of the trap. When the outlet valve opens, the condensate flows out of the trap into the drain system, and the float level drops, shutting off the valve until the condensate level rises again.

#### Bimetallic Steam Traps

Bimetallic steam traps of the type shown in figure 9-36 are used in many ships to drain

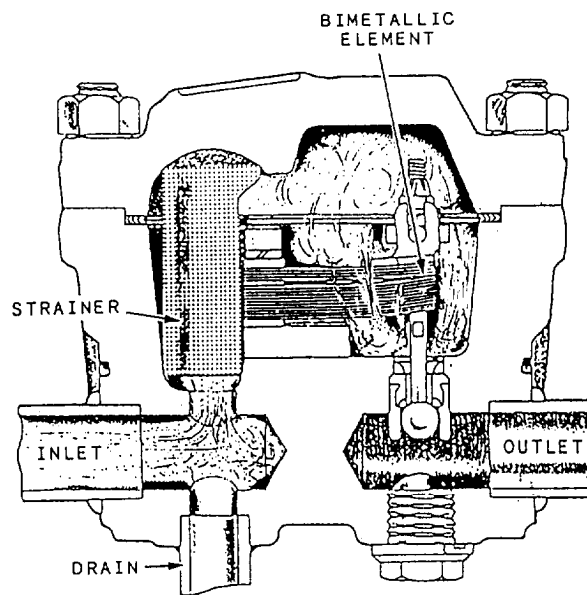

Figure 9-36.—Bimetallic steam trap.

condensate from main steam lines, auxiliary steam lines, and other steam components. The main working parts of this steam trap are a segmented bimetallic element and a ball-type check valve.

The bimetallic element has several bimetallic strips fastened together in a segmented fashion, as shown in figure 9-36. One end of the bimetallic element is fastened rigidly to a part of the valve body; the other end, which is free to move, is fastened to the top of the stem of the ball-type check valve.

Line pressure acting on the check valve keeps the valve open. When steam enters the trap body, the bimetallic element expands unequally because of the different response to the temperature of the two metals; the bimetallic element deflects upward at its free end, thus moving the valve stem upward and closing the valve. As the steam cools and condenses, the bimetallic element moves downward, toward the horizontal position, thus opening the valve and allowing some condensate to flow out through the valve. As the flow of condensate begins, an unbalance of line pressure across the valve is created; since the line pressure is greater on the upper side of the ball of the check valve, the valve now opens wide and allows a full capacity flow of condensate.

### Orifice Steam Traps

Aboard ship, continuous-flow steam traps of the orifice type are used in systems or services in which condensate forms at a fairly steady rate. Figure 9-37 shows one orifice-type steam trap.

Several variations of the orifice-type steam trap exist, but all have one thing in common—they have no moving parts. One or more restricted passageways or orifices allow condensate to trickle

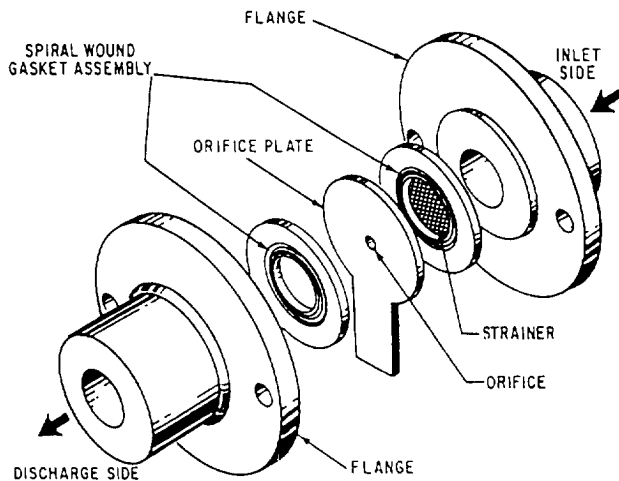

Figure 9-37.—Constant-flow drain orifice.

through but do not allow steam to flow through. Besides orifices, some orifice-type steam traps have baffles.

### MAINTENANCE

A strainer is installed just ahead of each steam trap. The strainer must be kept clean and in good condition to keep scale and other foreign matter from getting into the trap. Scale and sediment can clog the working parts of a steam trap and seriously interfere with the working of the trap.

Steam traps that are not operating properly can cause problems in systems and machinery. One way to check on the operation of a steam trap is to listen to it. If the trap is leaking, you will probably be able to hear it blowing through. Another way to check the operation of steam traps is to check the pressure in the drain system. A leaking steam trap causes an unusual increase in pressure in the drain system. When observing this condition, you can locate the defective trap by cutting out (isolating from the system) traps, one at a time, until the pressure in the drain system returns to normal.

You should disassemble, clean, and inspect defective steam traps. After determining the cause of the trouble, repair or replace parts as required. In some steam traps, you can replace the main working parts as a unit; in others, you may have to grind in a seating surface, replace a disk, or perform other repairs. You should reseal defective trap discharge valves. Always install new gaskets when reassembling steam traps.

### FILTERS AND STRAINERS

Fluids are kept clean in a system principally by devices such as filters and strainers. Magnetic

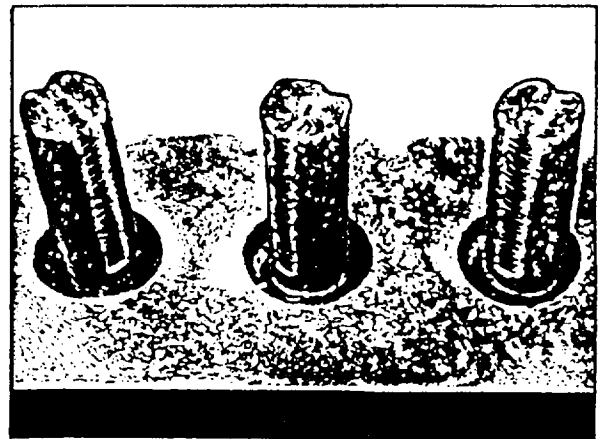

Figure 9-38.—Magnetic plugs.



plugs (fig. 9-38) also are used in some strainers to trap iron and steel particles carried by fluid. Studies have indicated that even particles as small as 1 to 5 microns have a degrading effect, causing failures and hastening deterioration in many cases.

There will always be controversy over the exact definitions of filters and strainers. In the past, many such devices were named filters but technically classed as strainers. To minimize the controversy, the National Fluid Power Association gives us these definitions:

**FILTER** - A device whose primary function is the retention, by some porous medium, of insoluble contaminants from a fluid.

**STRAINER** - A coarse filter.

To put it simply, whether the device is a filter or a strainer, its function is to trap contaminants from fluid flowing through it. The term *porous medium* simply refers to a screen or filtering material that allows fluid flow through it but stops various other materials.

**MESH AND MICRON RATINGS**

Filters, which may be made of many materials other than wire screen, are rated by MICRON size. A micron is 1-millionth of a meter or 39-millionths of an inch. For comparison, a grain of salt is about 70 microns across. The smallest particle visible to the naked eye is about 40 microns. Figure 9-39 shows the relationship of

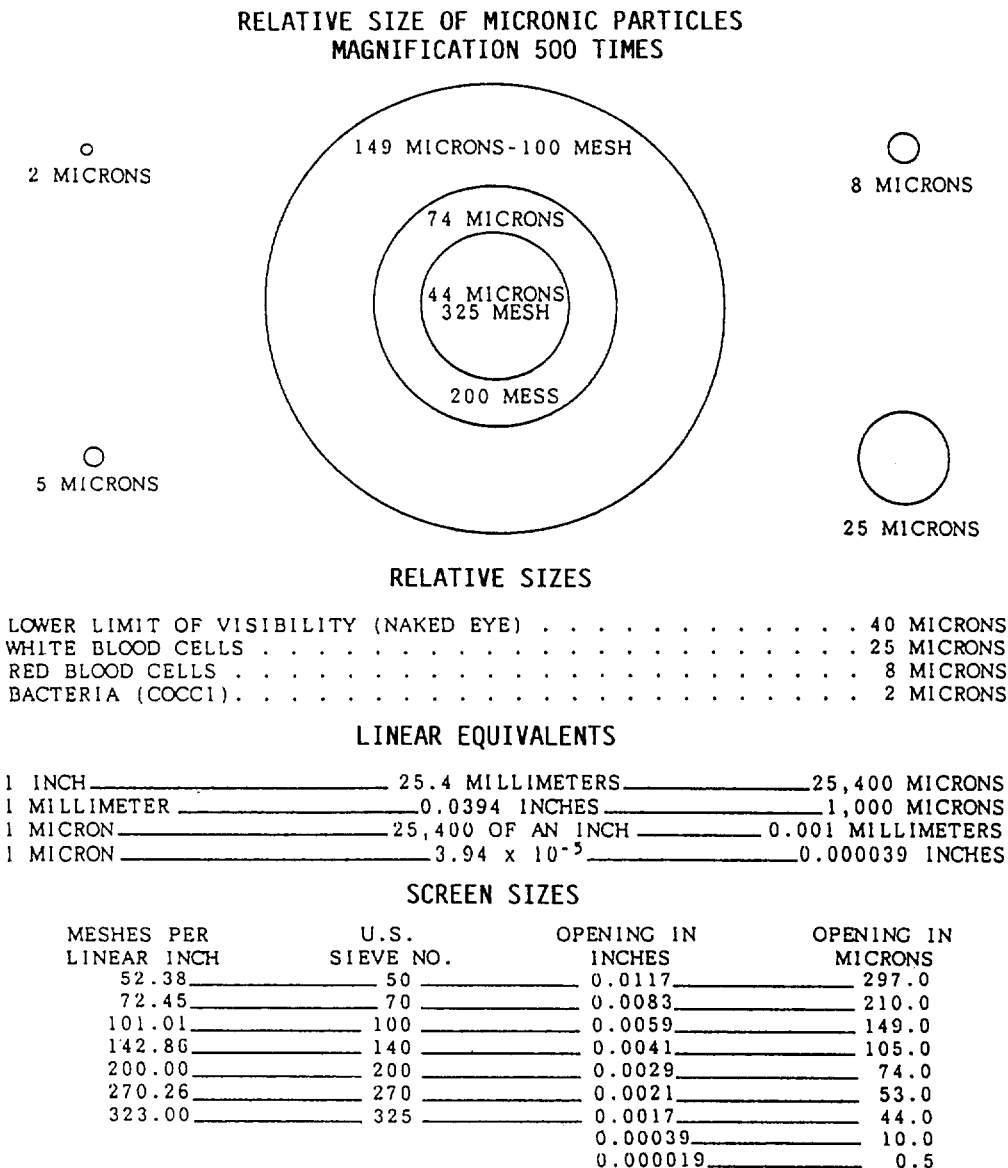

Figure 9-39.—Relationship of micron sizes.

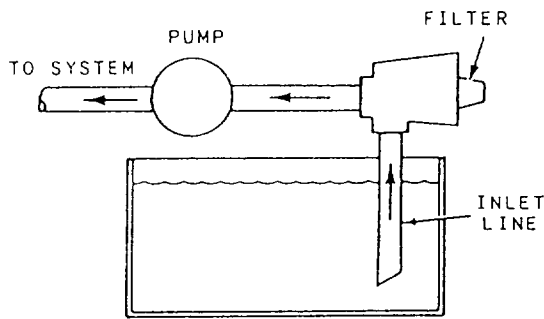

Figure 9-40.—Inlet line filter.

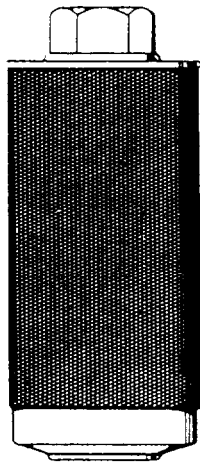

Figure 9-41.—Inlet strainer.

the various micron sizes with mesh and standard sieve sizes.

A simple screen or a wire strainer is rated for filtering fineness by a MESH number or its near equivalent, STANDARD SIEVE number. The higher the mesh or sieve number, the finer the screen.

When a filter is specified as so many microns, it usually refers to the filter's NOMINAL rating. A filter nominally rated at 10 microns, for example, would trap most particles 10 microns in size or larger. The filter's ABSOLUTE rating, however, would be a somewhat higher size, perhaps 25 microns. The absolute rating is the size of the largest opening or pore in the filter. Absolute rating is an important factor only when it is mandatory that no particles above a given size be allowed to circulate in the system.

#### FILTER/STRAINER LOCATION

There are three general areas in a system for locating a filter: the inlet line, the pressure line,

or a return line. Both filters and strainers are available for inlet lines. Filters are normally used in other lines.

#### Inlet Filters and Strainers

Figure 9-40 shows the location of an inlet line filter. An inlet line filter is usually a relatively coarse mesh filter. A fine mesh filter (unless it is very large) creates more pressure drop than can be tolerated in an inlet line.

Figure 9-41 shows a typical strainer of the type installed on pump inlet lines inside a reservoir. It is relatively coarse as filters go, being constructed of fine mesh wire. A 100-mesh strainer protects the pump from particles about 150 microns in size.

#### Pressure Line Filters

A number of filters are designed for installation right in the pressure line (fig. 9-42) and can trap much smaller particles than inlet line

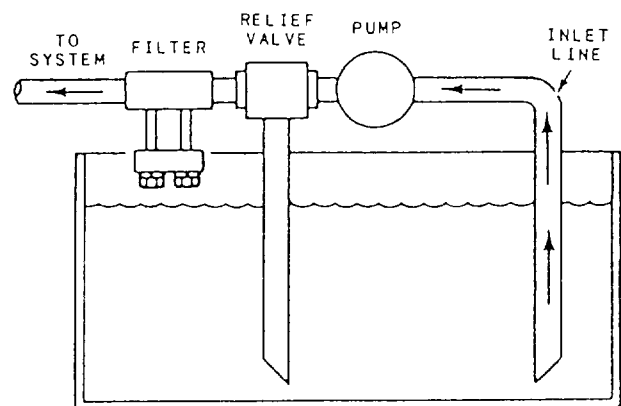

Figure 9-42.—Pressure line filter.

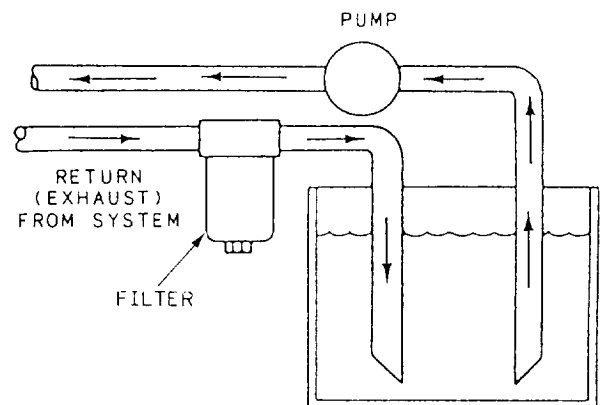

Figure 9-43.—Return line filter.

filters. Such a filter might be used where system components, such as valves, are less dirt-tolerant than the pump. The filter thus would trap this fine contamination from the fluid as it leaves the pump. Pressure line filters must be able to withstand the operating pressure of the system.

### Return Line Filters

Return line filters (fig. 9-43) also can trap very small particles before the fluid returns to the reservoir/tank. They are particularly useful in systems that do not have large reservoirs/tanks to allow contaminants to settle out of the fluid. A return line filter is nearly a must in a system with a high-performance pump, which has very close clearances and usually cannot be sufficiently protected by an inlet line filter.

### FILTER/STRAINER MATERIALS

The materials used in filters and strainers are classified as mechanical, absorbent, or adsorbent. Most strainer material is of the mechanical type, which operates by trapping particles between closely woven metal screens and/or disks, and metal baskets. The mechanical type of material is used mostly where the particles removed from the medium are of a relatively coarse nature.

Absorbent filters are used for most minute-particle filtration in fluid systems. They are made of a wide range of porous materials, including paper, wood pulp, cotton, yarn, and cellulose.

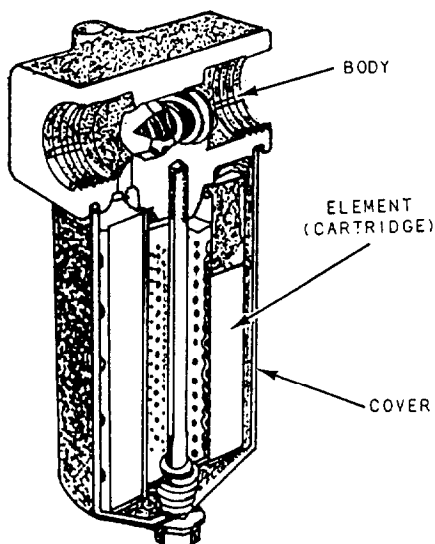

Figure 9-44.—Filter assembly using a surface-type element.

Paper filters are usually resin-impregnated for strength.

Adsorbent (or active) filters, such as charcoal and fuller's earth, are used mostly in gaseous or vapors systems. This type of filter material should not be used in hydraulic systems since they remove essential additives from the hydraulic fluid.

### CONSTRUCTION OF FILTER ELEMENTS

Filter elements are constructed in various ways. The three most common filter element construction types are the surface type (most common), the depth type, and the edge type.

Surface-type filter elements (fig. 9-44) are made of closely woven fabric or treated paper with pores to allow fluid to flow through. Very accurate control of the pore size is a feature of the surface-type elements.

A depth-type filter element (fig. 9-45) is composed of layers of a fabric or fibers, which provide many tortuous paths for the fluid to flow through. The pores or passages vary in size, and the degree of filtration depends on the flow rate. Increases in flow rate tend to dislodge trapped particles. This filter is limited to low-flow, low pressure-drop conditions.

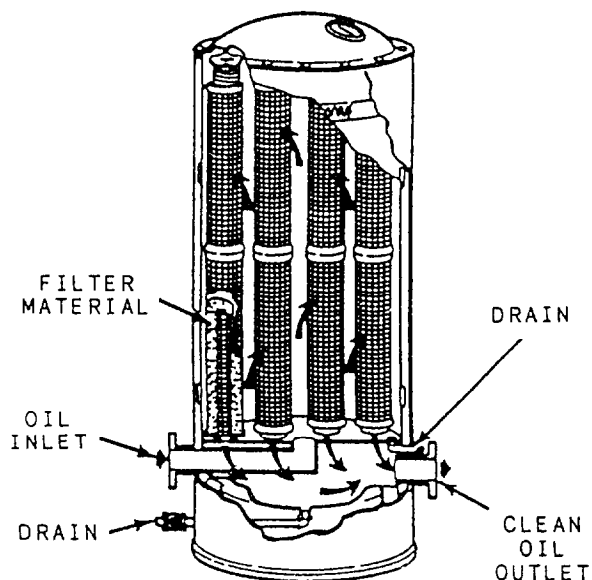

Figure 9-45.—Depth-type filter element.

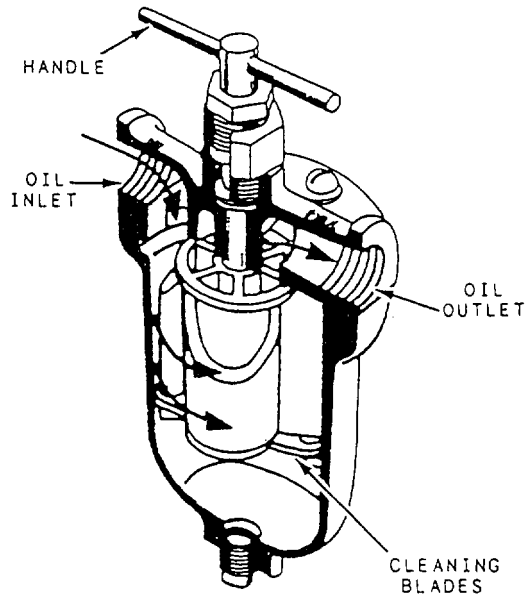

Figure 9-46.—Edge-type filter element.

An edge-type filter element (fig. 9-46) separates particles from fluids passing between finely spaced plates. The filter shown features stationary cleaner blades that scrape out the collected contaminants when the handle is twisted to turn the element.

## TYPES OF FILTERS

In this section we will discuss the various filters (simplex, duplex, full flow, proportional flow, and indicator) that you will most frequently find installed in equipment.

### Simplex Filter

The simplex filter has one or more cylindrically shaped fine mesh screens or perforated metal sheets. The size of the opening in the screens or the perforated metal sheets determines the size of particles filtered out of the fluid. The design of this type of filter is such that total flow must pass through a simplex filter.

### Duplex Filters

Duplex filters are similar to simplex filters except in the number of elements and in provision for switching the flow through either element. A duplex filter may consist of a number of single element filters arranged in parallel operation, or it may consist of two or more filters arranged

within a single housing. The full flow can be diverted, by operation of valves, through any single element. The duplex design is most commonly used in fuel or hydraulic systems because the ability to shift to an off-line filter when the elements are cleaned or changed is desirable without the system being secured.

### Full-Flow Filters

The term *full-flow* applied to a filter means that all the flow into the filter inlet port passes through the filtering element. In most full-flow filters, however, there is a bypass valve preset to open at a given pressure drop and divert flow past the filter element. This prevents a dirty element from restricting flow excessively. Figure 9-47 shows a full-flow filter. Flow, as shown, is out-to-in; that is, from around the element, through it to its center. The bypass opens when total flow can no longer pass through the contaminated element without raising the system pressure. The element is replaceable after removing a single bolt.

### Proportional-Flow Filters

A proportional-flow filter (fig. 9-48) may use the venturi effect to filter a portion of the fluid flow. The fluid can flow in either direction. As it passes through the filter body, a venturi throat causes an increase in velocity and a decrease in

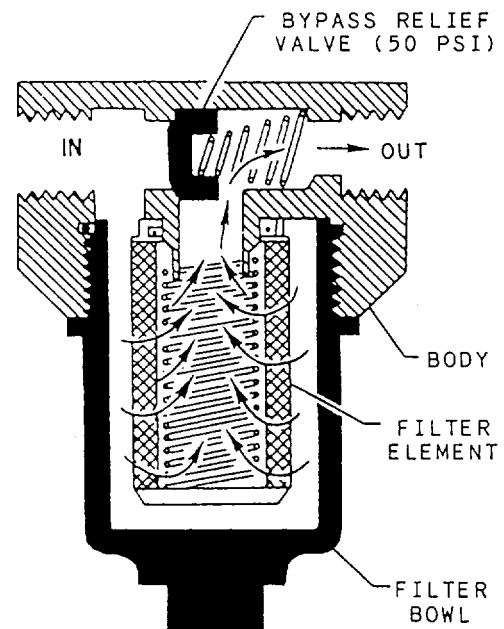

Figure 9-47.—Full-flow filter.

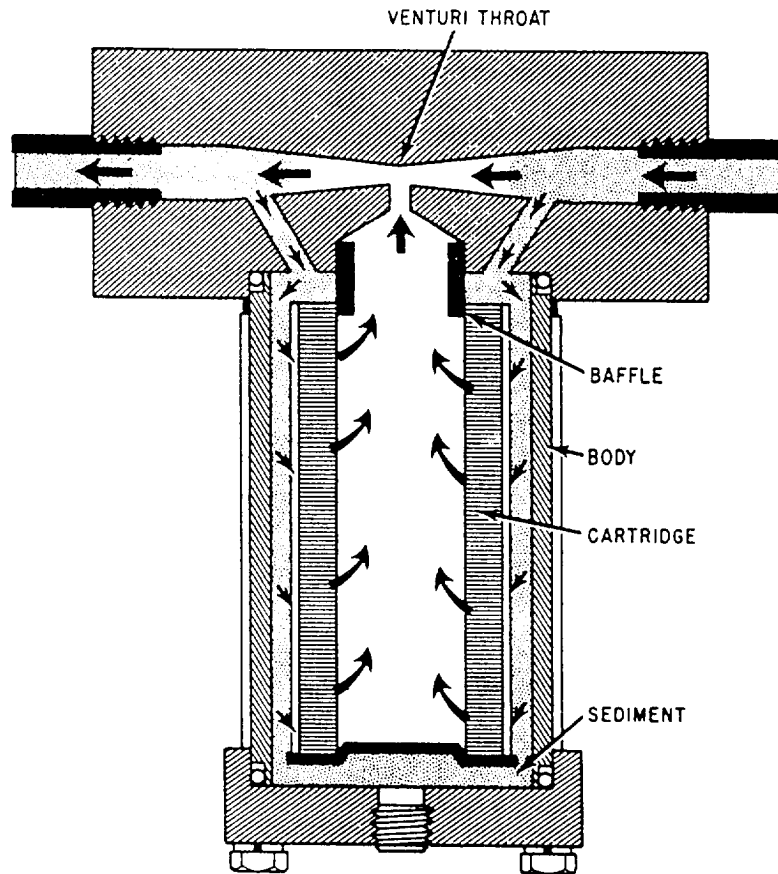

Figure 9-48.—Proportional-flow filter,

pressure. The pressure difference forces some of the fluid through the element to rejoin the main stream at the venturi. The amount of fluid filtered is proportional to the flow velocity. Hence, the name proportional-flow filter.

### Indicating Filters

Indicating filters are designed to signal the operator when the element needs cleaning. There are various types of indicators, such as color-coded, flag, pop-up, and swing arm. Figure 9-49 shows a color-coded indicating filter. The element is designed so it begins to move as the pressure increases due to dirt accumulation. One end is linked to an indicator that shows the operator just how clean or dirty the element is. Another feature of this type of filter is the ease and speed with which the element can be removed and replaced. Most filters of this kind are designed for inlet line installation.

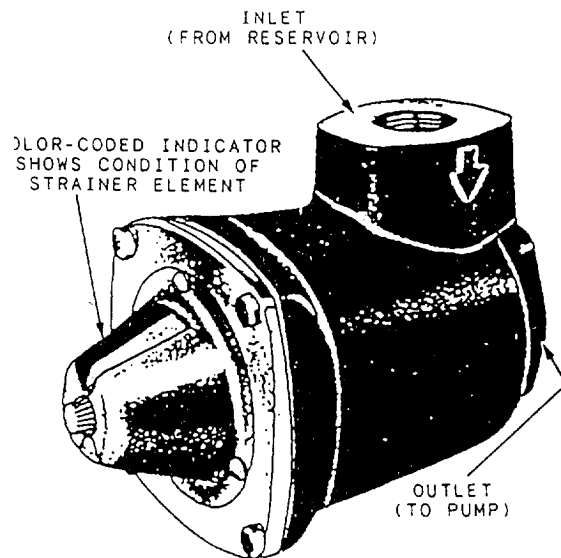

Figure 9-49.—Color-coded indicating filter.

## Filter/Separator

The filter/separator is a two-stage unit consisting of a coalescer stage and a separator stage within a single housing. Each stage is made up of replaceable elements, the number of which is determined by such considerations as the capacity of the elements in gallons per minute (gpm) and the elements dirt retaining properties. Coalescer elements filter solids from the fluid and cause small particles of undissolved water to combine (coalesce) into larger drops of water that, because of their weight, will settle in the filter/separator sump. Separator elements are provided to remove any remaining free water that has not coalesced. Water that accumulates in the filter/separator sump is removed through a drain line, either automatically or manually.

## In-Line or Cone Filter

In-line or cone filters have conical-shaped fine mesh screen or perforated metal sheet that is inserted into the system pipe and secured by a set of flanges. Its system application determines whether it is considered a filter or strainer. It is most commonly used in seawater systems, where it is considered a strainer. This type of filter is prohibited in fuel systems.

## MAINTENANCE

Proper operation of filters, strainers, and filter separators is essential for satisfactory gas turbine and diesel engine performance. Besides clogging the systems with foreign matter, continued operation with unfiltered fluids results in accelerated pump wear and system degradation. Routine maintenance of filters, strainers, and filter/separator is adequately covered in *NSTM*, Chapter 541, "Petroleum Fuel Stowage, Use, and Testing," paragraphs 541-8.51 through 541-8.59.

## PIPING

The control and application of fluid power would be impossible without a suitable means of conveying the fluid from the power source to the point of application. Fluid lines used for this purpose are called piping. They must be designed and installed with the same care applicable to other components of the system. To obtain this desired result, attention must be given to the various types, materials, and sizes of lines available for the fluid power system. The different types of lines and their application to fluid power systems are described in the first part of this section. The last part of this section is devoted

to the various connectors applicable to the different types of fluid lines.

## IDENTIFICATION OF PIPING

The three most common lines used in fluid power systems are pipe, tubing, and flexible hose. They are sometimes referred to as rigid (pipe), semirigid (tubing), and flexible piping. In commercial usage, there is no clear distinction between piping and tubing, since the correct designation for each product is established by the manufacturer. If the manufacturer calls its product pipe, it is pipe; if the manufacturer calls it tubing, it is tubing.

In the Navy, however, a distinction is made between pipe and tubing. The distinction is based on the method used to determine the size of the product. There are three important dimensions of any tubular product—outside diameter (OD), inside diameter (ID), and wall thickness. The product is called tubing if its size is identified by actual measured outside diameter and by actual wall thickness. The product is called pipe if its size is identified by a nominal dimension and wall thickness.

## PIPING MATERIALS

The pipe and tubing used in fluid systems today are commonly made from steel, copper, brass, aluminum, and stainless steel. The hose assemblies are constructed of rubber or Teflon. Each of these materials has its own distinct advantages or disadvantages, depending upon its application.

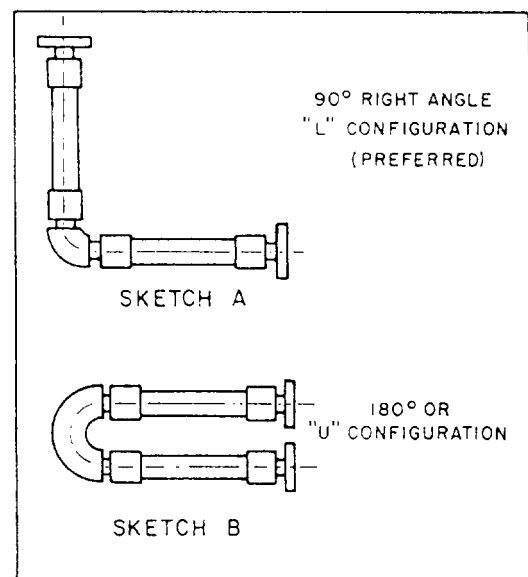

Figure 9-50.—Types of flexible hose installations and fittings.

Steel piping and tubing are relatively inexpensive, have a high tensile strength, are suitable for bending and flanging, and are very adaptable to high pressures and temperatures. Its chief disadvantage is a comparatively low resistance to corrosion.

Copper and brass piping and tubing have a high resistance to corrosion and are easily drawn or bent. Pipe or tubing made from these materials is unsuitable for systems with high temperatures, stress, or vibration because they have a tendency to harden and break.

Aluminum has many characteristics and qualities required for fluid systems. It has a high resistance to corrosion, is lightweight, is easily drawn or bent, and (when combined with certain alloys) will withstand high pressures and temperatures.

Stainless steel piping or tubing is relatively lightweight and is used in a system that will be exposed to abrasion, high pressure, and intense heat. Its main disadvantage is high cost.

## FLEXIBLE HOSE ASSEMBLIES

The flexible hose assembly is a specific type of flexible device that uses reinforced rubber hose and metal end fittings. It is used to absorb motions between resiliently mounted machinery and fixed or resiliently mounted piping systems. The motions to be considered may be of either relatively large size due to high-impact shock or of smaller size due to the vibratory forces of rotating machinery. The configuration selected must contain enough hose to accommodate shock and vibratory motions without stressing the hose assembly or machinery to an unacceptable degree.

### Approved Flexible Hose Configurations

The arrangements (or configurations) determined to give the best noise attenuation characteristics and to accommodate the motions of resiliently mounted equipment are shown in figures 9-50 and 9-51. The 90° "L" configuration

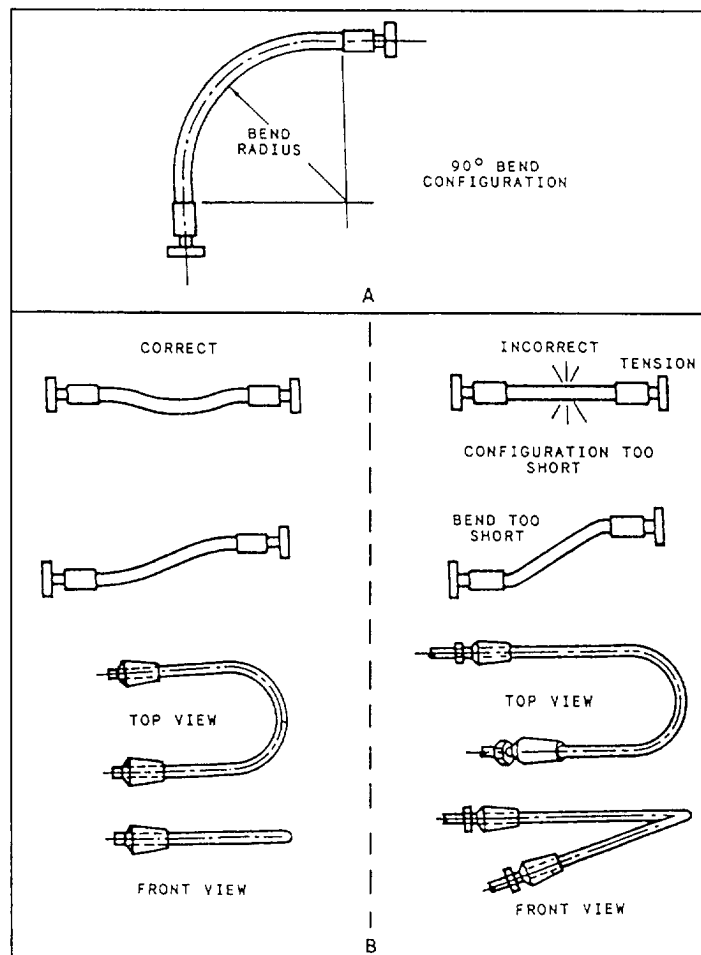

Figure 9-51.—Other approved single hose length configurations.

(dogleg) is the preferred configuration; however, where space and piping arrangement prohibit the use of the “L” configuration, a 180° or “U” configuration may be used. The 90° “L” and 180° “U” configurations are shown as sketches A and B of figure 9-50.

A configuration that uses a single length of hose bent to about 90° is approved where the hose does not bend below its specified minimum bending radius when the equipment moves to the maximum limits allowed by its mounts (view A of fig. 9-51). The straight single hose configuration and the 180° single hose bend (view B of fig. 9-51) are also approved for use where the hose size is less than 1 inch ID.

Flexible connections that use rubber hose are not used in systems where the maximum continuous operating temperature is in excess of 200°F.

### **Hose Identification**

Hose is identified by the manufacturer’s part number and the size or dash number. The dash number is the nominal hose inside diameter in sixteenths of an inch. Hose built to military specification (MILSPEC) requirements have the number of the specification and, where applicable, the class of hose, the quarter and year of manufacture, and the manufacturer’s trademark. This information is molded or otherwise permanently repeated periodically on the hose cover (sometimes referred to as the “lay line marking”). Other information permanently marked on the hose cover is the manufacturer’s code and the date of manufacture. For interpretations of commercial lay line markings, refer to the appropriate manufacturer’s catalog or manual.

### **Fitting Identification**

Use special care in identifying hose fittings because their designation is more complex than hose. A fitting suitable for connecting to a given hose size can end in more than one size and type of connection to the piping. A fitting, therefore, must be identified by the manufacturer’s part number, the size of the end connection that joins the piping system, and the dash size to show the size hose to which it makes up. For interpretation of manufacturer markings, consult the appropriate manufacturer’s manual. Fittings meeting military specification requirements have the specification number, class of fitting (where applicable), type, size, and manufacturer’s trademark.

A cross index between the manufacturers’ designations and military specifications and information to correctly identify approved hoses and fittings can be found in *Piping Devices, Flexible Hose Assemblies*, volume 1, NAVSEA S6430-AE-TED-010.

### **Inspection of Hose and Fittings Prior To Make-Up**

The basic inspection methods for hose and fittings are listed as follows:

1. Ensure that the hose and couplings are the correct ones for the intended use and that the age of the rubber hose does not exceed a shelf life of 4 years. Teflon and metal hose have no limiting shelf life.
2. Inspect for signs that the hose has been twisted. Use the hose lay line for a guide to determine whether or not any twist is present. If twisted, reject.
3. Inspect for signs that the hose has been kinked or bent beyond its minimum bend radius. If suspect, reject.
4. Inspect for signs of loose inner liner. If found, cut the hose to see if this condition exists throughout the entire length. If suspect, reject.
5. Visually check the inner liner and outer rubber cover of the hose for breaks, hairline cuts, or severe abrasions. If any suspect areas are found, reject.
6. Inspect the fittings for defects, such as cracked nipples and damaged threads. If suspect, or if defects are found, reject.

Procedures for making up hoses and fittings can also be found in the *NSTM*, chapter 505, or the appropriate manufacturer’s catalog or manual, and are not covered here due to the many types available.

### **Visual Inspection**

After assembling the hose and fittings, visually inspect the entire configuration to ensure the following:

1. The hose inner liner and outer cover is intact and contains no cuts or harmful abrasions.
2. The hose has not been twisted (check the lay line).



3. The circumferential chalk line on the hose next to the coupling has been drawn before the hydrostatic test.
4. The internal spring (if installed) is evenly spaced and flat against the inner liner. Ensure a gap exists between one of the end fittings and the end of the spring.

### Hydrostatic Test

Upon completion of visual inspection, hydrostatically shop test the hose assembly with fresh water. For each style and size of hose, test the pressure to ensure that it is twice the maximum allowable pressure shown in chapter 505 of the *NSTM*. When you test pressure, hold for not more than 5 minutes nor less than 60 seconds. When test pressure is reached, visually inspect the hose assembly for the following defects:

1. Leaks or signs of weakness
2. Twisting of the hose (this indicates that some twist existed before pressure was applied)
3. Slippage of the hose out of the coupling (a circumferential chalk line can help determine this)

If any of these defects occur, reject the assembly.

### CAUTION

Do not confuse hose elongation under pressure with coupling slippage. If the chalk line returns to near its original position, no slippage has occurred and the assembly is satisfactory. If there is any doubt, perform a second test. If doubt persists after the second test, reject the assembly.

### Air Test

Hose assemblies intended for gas or air service must also be tested with air or nitrogen at 100 psi and the assembly immersed in water. Random bubbles may appear over the hose and

in the fitting area when the assembly is first pressurized. Do not construe this as a defect. However, if the bubbles persist in forming at a steady rate at any particular point on the hose, reject the assembly.

### Installation of Flexible Hose Assemblies

After completion of tests, proceed as follows:

1. Install as soon as possible.
2. Do not leave the hose assembly around on decks or on docks where they can be subjected to any form of abuse.
3. Make up hose assemblies as late as possible during the availability schedule to minimize the chances of damage while the ship is being overhauled.
4. Install plastic dust caps, plugs, or tape ends to protect threaded areas until the hose assembly is installed.

When installing flexible base connections, observe the following requirements:

1. Ensure each leg of hose is free of twist between end fittings.
2. Ensure the fixed piping near the flexible configuration is properly supported so that it does not vibrate from the resiliently mounted equipment.
3. Ensure the configurations are clear of all surrounding structures and remain so when resiliently mounted equipment moves through its maximum excursion under shock.
4. Locate flexible connections as close as possible to the sound-mounted unit.
5. Support the free elbow of the configuration with an approved pipe hanger so as not to sag or otherwise unduly stress or distort the configuration.
6. Do not appreciably change the alignment of the hose configuration between the unpressurized and pressurized conditions. If you do, you could cause misalignment or improper support at the fixed end.

HOSE ASSEMBLY IDENTIFICATION TAG (SHIP _____)	
SRD DWG NO _____	SYST. PRESSURE _____ PSI
SRP ITEM NO _____	START SERVICE
HOSE TYPE/SIZE _____	DATE _____
SERVICE _____	

A  
ID TAG WHEN SELECTED RECORD DRAWING IS AVAILABLE

HOSE ASSEMBLY IDENTIFICATION TAG (SHIP _____)	
PIPING ARR. DWG. NO. _____	SYST. PRESSURE _____ PSI
ASSY. PC. NO. _____	START SERVICE
HOSE TYPE/SIZE _____	DATE _____
SERVICE _____	

B  
ID TAG WHEN SELECTED RECORD DRAWING DOES NOT EXIST

Figure 9-52. Hose assembly identification tags.

- Obtain metal hose assembly identification tags (fig. 9-52) from your local SIMA and secure them onto one of the legs of the hose configuration. The tag is made of a non-corroding material. Do not remove or alter the tag once it is attached.
- Leave the configuration in a condition where one end can hang down unsupported during installation or dismantling of piping. Otherwise, you can damage the hose wire reinforcement.
- Slippage of hose out of fitting.
- Twisting of hose or other distortion or unusual appearance.
- Cracking of outer rubber cover.
- Rubber cover rubbed thin by abrasion or chafing.
- High pulsations, fluid hammer, or whipping caused by pressure pulsations.
- Large vibrations due to improper supports at the fixed end.
- Large area of hose covered with paint. (The intent of this requirement is to eliminate having the flexible hose connections deliberately painted. The hose does not have to be replaced if a few paint drops inadvertently fall onto it. Do not attempt to clean off dried paint from the hose.)

### Periodic Inspection By Ship's Force

No less than once a quarter, preferably about once a month, visually inspect all flexible piping connections to determine whether any signs of weakness or unusual conditions exist. Inspect the hose in other systems semiannually. To assist you when performing this inspection, you should compile a checkoff list of hose assemblies and locations for your assigned spaces or equipment. This list will consist of all flexible devices installed (and their locations) together with a list of inspections to be performed on each flexible device. When you perform the listed inspections, note the following:

- Evidence of leakage at fitting ends.
- Discoloration of fittings (possible indication wire reinforcement is rusting).
- Check hangers to ensure they have not broken off, become distorted, or been otherwise damaged.
- Soft spots or bulges on hose body (indicates weakening of bond between outer rubber cover and wire braid or deterioration of the reinforcing wire).
- If results of visual inspection indicates weakening of hose or fittings, or makes hose configuration suspect, replace the hose immediately, if at all possible. Keep under surveillance while under pressure until it is replaced.

13. If necessary to remove a flexible hose configuration from the system, examine the interior of the hose for cracks or other signs of deterioration of the inner liner. Do not damage the liner by trying to dislodge sea growth. Do not remove the end fittings from any section of hose that is to be installed.
14. Presence of identification tag.

### Storage

The following guidelines are recommended for proper storage of hose and fittings:

- Hose—Hose should be stored in a dark, dry atmosphere away from electrical equipment; temperature should not exceed 125°F. Storage in straight lengths is preferred, but if hose is to be coiled, take care to ensure the diameter of the bend is not less than 3 feet. To prevent damage during storage, wrap the hose with burlap or other suitable material.
- Reusable end fittings—Protect all threads with tape or other suitable material, and wrap the entire fitting in a protective covering to prevent nicking or other damage.

### Shelf Life

The following are shelf life requirements for hose and reusable end fittings:

- Hose—Do not install reinforced rubber hose that is over 4 years old from the date of manufacture. This time is measured from the quarter and year of manufacture but does not include the quarter year of manufacture. Consider the shelf life of hose ended upon installation aboard ship. To ensure against its accidental use, dispose of any hose not installed that has exceeded the above shelf life.
- Reusable end fittings—There is no shelf life for end fittings. They should be replaced on an individual basis when examination makes them suspect.

### Servicing

No servicing or maintenance is required since hose or fittings must be replaced at the slightest suspicion of potential failure. If a fitting is removed from a section of hose, that hose section must not be reused, regardless of its service life.

### Service Life of Rubber Hose

All rubber hose has a periodic replacement time. All flexible rubber hose connections will be replaced every 5 years ( $\pm 6$  months) in critical systems and every 12 years in noncritical systems. Wire braided Teflon hose has no specified shelf or service life. Its replacement is based on inspection of the hose for excessive wear or damage.

### FITTINGS

Some type of connector must be provided to attach the pipe, tube, or hose to the other components of the system and to connect sections of the line to each other. There are many different types of connectors (commonly called fittings) provided for this purpose. Some of the most common types of fittings are covered in the following paragraphs.

#### Threaded Joints

The threaded joints are the simplest type of pipe fittings. Threaded fittings are not widely used aboard modern ships except in low-pressure water piping systems. The pipe ends connected to the union are threaded, silver-brazed, or welded into the tail pieces (union halves); then the two ends are joined by setting up (engaging and tightening up on) the union ring. The male and female connecting ends of the tail pieces are carefully ground to make a tight metal-to-metal fit with each other. Welding or silver-brazing the ends to the tail pieces prevents contact of the carried fluid or gas with the union threading.

#### Bolted Flange Joints

Bolted flange joints (fig. 9-53) are suitable for all pressures now in use. The flanges are attached

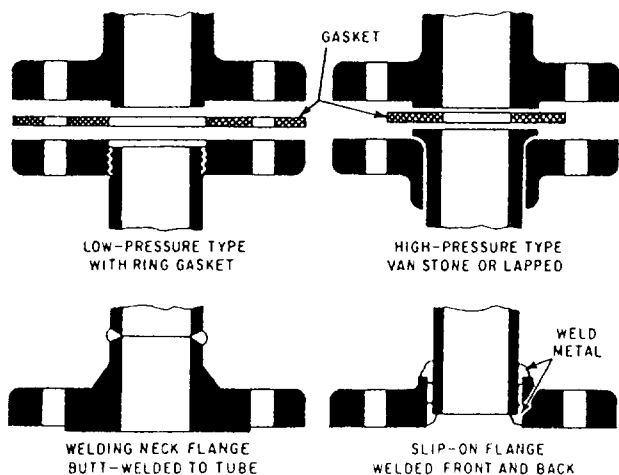

Figure 9-53.—Four types of bolted flange piping joints.

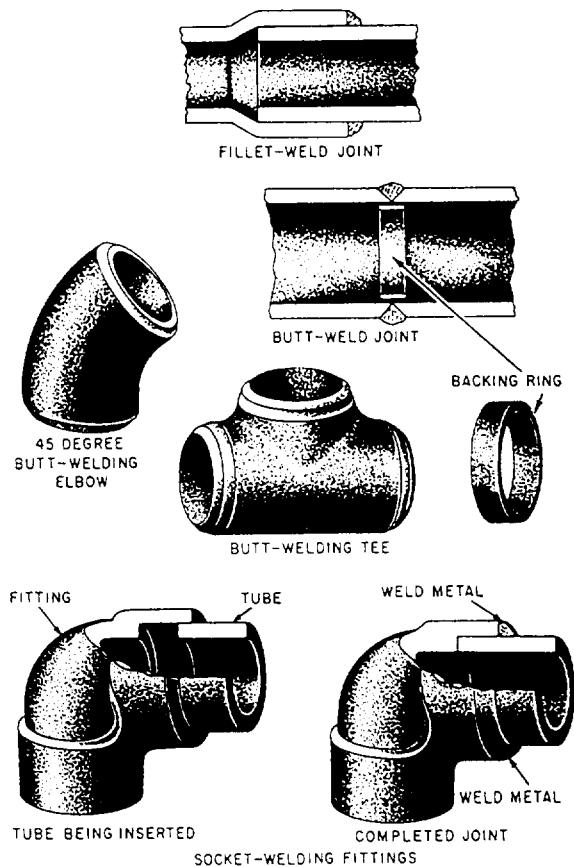

Figure 9-54.—Various types of welded joints.

to the piping by welding, brazing, screw threads (for some low-pressure piping), or rolling and bending into recesses. Those shown in figure 9-53 are the most common types of flange joints used. Flange joints are manufactured for all standard fitting shapes, such as the tee, cross, elbow, and return bend. The Van Stone and the welded-neck flange joints are used extensively where piping is subjected to high pressures and heavy expansion strains. The design of the Van Stone flange makes it easier to line up the fastening holes in the two parts of the flange.

### Welded Joints

The majority of joints found in subassemblies of piping systems are welded joints, especially in high-pressure piping. The welding is done according to standard specifications, which define the material and techniques. Three general classes of welded joints are fillet-weld, butt-weld, and socket-weld (fig. 9-54).

### Silver-Brazed Joints

Silver-brazed joints (fig. 9-55) are commonly used for joining nonferrous piping when the pressure and temperature in the lines make their use practicable—temperatures must not exceed 425°F; for cold lines, pressure must not exceed 3000 psi. The alloy is melted by heating the joint with an oxyacetylene torch. This causes the molten metal to fill the few thousandths of an inch annular space between the pipe and the fitting.

### Unions

The union fittings are provided in piping systems to allow the piping to be taken down for

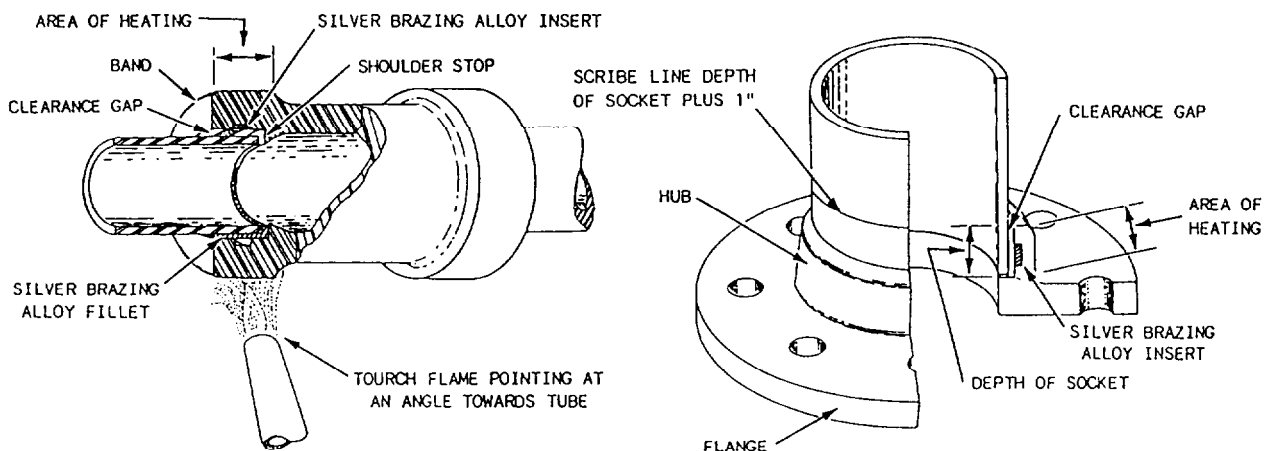

Figure 9-55.—Silver-brazed joints.

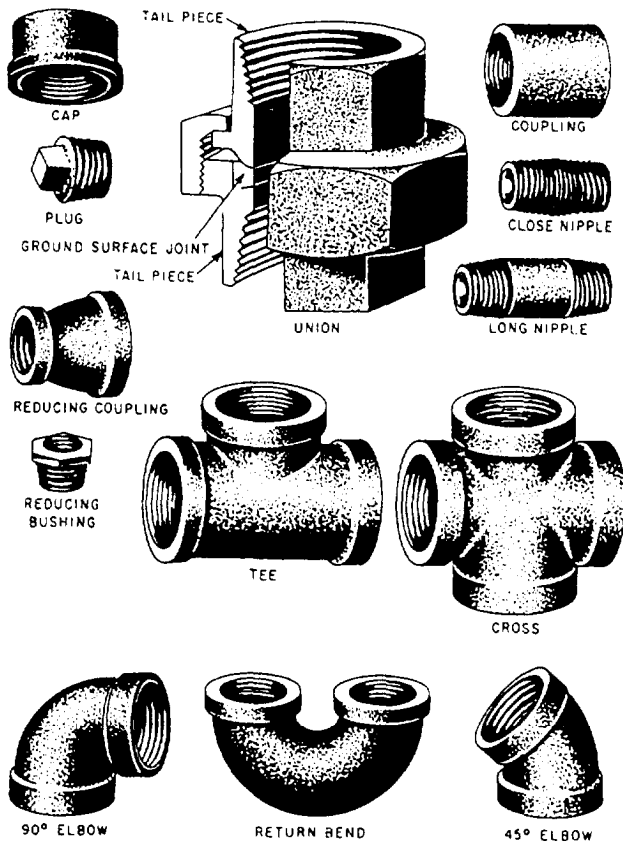

Figure 9-56.—Unions/threaded pipe connectors.

repairs and alterations. Unions are available in many different materials and designs to withstand a wide range of pressures and temperatures. Figure 9-56 shows some commonly used types of unions/threaded pipe connectors. The union is most commonly used for joining piping up to 2 inches in size.

### Flared Fittings

Flared fittings are commonly used in tubing lines. These fittings provide safe, strong, dependable connections without the necessity of threading, welding, or soldering the tubing. Flared fittings are made of steel, aluminum alloy, or bronze. Do not mix materials when using these fittings. For example, for steel tubing use only steel fittings and for copper or brass tubing use only bronze fittings. Figure 9-57 shows the most common types of flared fittings.

### Flareless Fittings

Flareless fittings (figs. 9-58 and 9-59) are suitable for use in hydraulic service and air

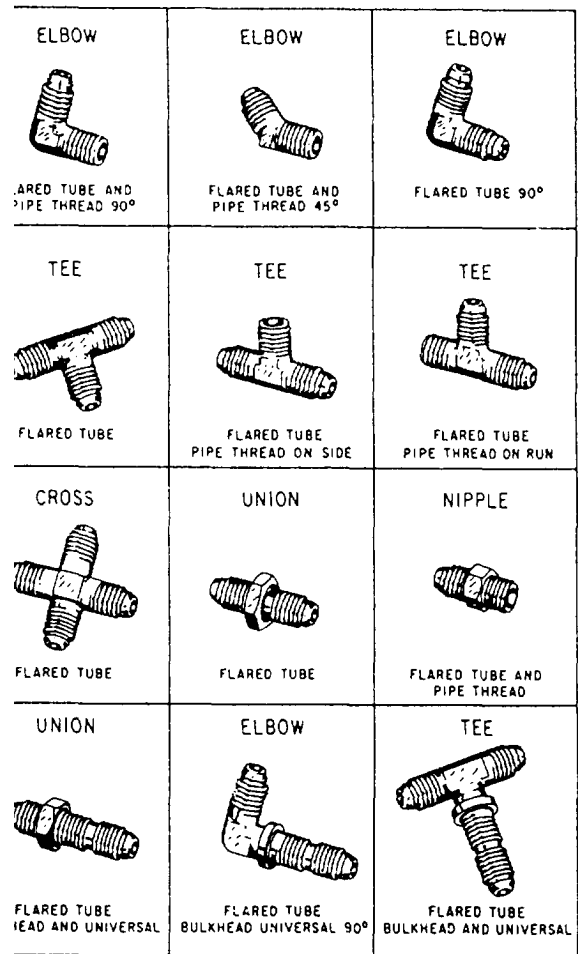

Figure 9-57.—Flared-tube fittings.

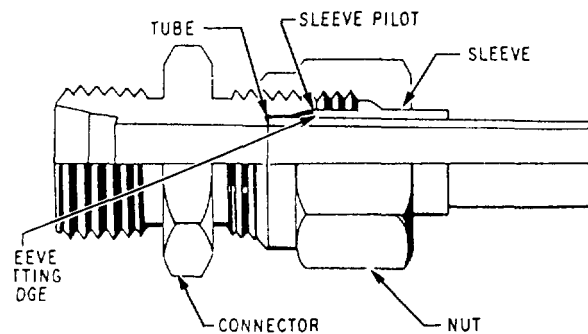

Figure 9-58.—Double-male flareless fitting.

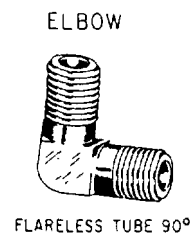

Figure 9-59.—Typical flareless fitting.

service systems at a maximum operating pressure of 3000 psi and a maximum operating temperature of 250°F. Flareless fittings are installed to conserve space and to reduce weight, installation time, and system cleaning time. Do not use flareless fittings if you do not have enough space to properly tighten the nuts or if you have to remove the equipment or piping for access to the fittings. An exception to this rule is a gauge board. It is designed so it may be removed as a unit for repairs or alterations. Do not use flareless fittings where you cannot easily deflect the piping to permit assembly and disassembly.

Before assembly, ensure the tubing end is square, concentric, and free of burrs. For an effective fitting, be sure the cutting edge of the sleeve or ferrule bites into the periphery of the tube; you can do this by presetting the ferrule.

### FLANGE SAFETY SHIELDS

A fuel fire in the MER or an AMR can be caused by a leak at a fuel oil or lube oil pipe flange connection. Even the smallest leak can spray fine droplets of oil on nearby hot surfaces. To reduce this possibility, FLANGE SAFETY SHIELDS are provided around piping flanges of inflammable liquid systems, especially in areas where the fire hazard is apparent. The spray shields are usually made of aluminized glass cloth and are simply wrapped and wired around the flange.

### PIPE HANGERS

Pipe hangers and supports are designed and located to support the combined weight of the piping, fluid, and insulation. They absorb the movements imposed by thermal expansion of the pipe and the motion of the ship. The pipe hangers and supports prevent excessive vibration of the piping and resilient mounts or other materials. They are used in the hanger arrangement to break all metal-to-metal contact to lessen unwanted sound transmissions.

One type of pipe hanger you need to become familiar with is the variable spring hanger. This is used to support the ship's bleed air piping. It provides support by directly compressing a spring or springs. The loads carried by the hangers are equalized by adjustment of the hangers when they are hot. These hangers have load scales attached to them with a traveling arm or pointer that moves in a slot alongside the scale. This shows the degree of pipe movement from cold to hot. The cold and hot positions are marked on the load scale. You

should check the hangers when they are hot to ensure that the pointers line up with the hot position on the load scales. You can adjust hangers that are out of position by loosening the jam nut on the hanger rod and turning the adjusting bolt of the hanger.

### INSPECTIONS AND MAINTENANCE

Reasonable care must be given to the various piping assemblies as well as to the units connected to the piping systems. Unless the piping system is in good condition, the connected units of machinery cannot operate efficiently and safely. You should be familiar with all the recommended maintenance procedures and observe the safety precautions when working on piping systems.

The most important factor in maintaining piping systems in satisfactory condition is keeping joints, valves, and fittings tight. To ensure this condition, you need to make frequent tests and inspections.

Piping should be tested at the frequency and test pressure specified following the PMS and the applicable equipment technical manual. Test pressure must be maintained long enough to show any leaks or other defects in the system.

Instruction manuals should be available and followed for the inspection and maintenance of piping systems and associated equipment; however, if the manufacturer's instruction manual is not available, you should refer to the *NSTM*, chapter 505, for details of piping inspection and maintenance.

### PIPING SYSTEM IDENTIFICATION MARKING

All piping should be marked to show the name of the service, destination (where possible), and direction of flow (fig. 9-60).

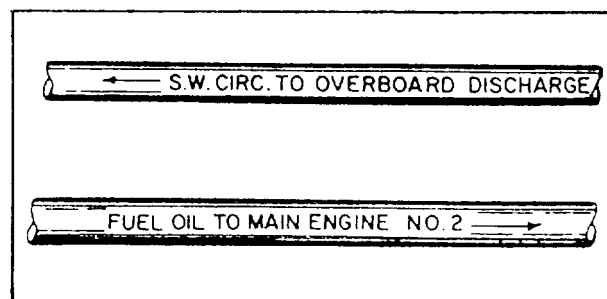

Figure 9-60.—Pipe markings.

The name of the service and destination should be painted on by stencil or hand lettering, or by application of previously printed, stenciled, or lettered adhesive-backed tape. Lettering will be 1 inch high for a 2-inch or larger OD bare pipe or insulation. For smaller sizes, lettering size may be reduced or label plates attached by wire or other suitable means.

Direction of flow will be indicated by an arrow 3 inches long pointing away from the lettering. For reversible flow, arrows are to be shown on each end of the lettering.

Black is used for lettering and arrows. However, on dark-colored pipe (including oxygen piping), white is used.

Markings will be applied to piping in conspicuous locations, preferably near the control valves and at suitable intervals so every line will have at least one identification marking in each compartment through which it passes. Piping in cabins and officers' wardrooms will not normally be marked.

## **PACKING AND GASKET MATERIAL**

Packing and gasket materials are required to seal joints in steam, water, gas, air, oil, and other lines and to seal connections that slide or rotate under normal operating conditions. There are many types and forms of packing and gasket materials available commercially.

## **PACKING AND GASKET SELECTION**

To simplify the selection of packing and gasket materials commonly used in naval service, the Naval Sea Systems Command has prepared a packing and gasket chart, Mechanical Standard Drawing B-153. It shows the symbol numbers and the recommended applications for all types and kinds of packing and gasket materials.

The symbol number used to identify each type of packing and gasket has a four-digit number. The first digit shows the class of service with respect to fixed and moving joints; the numeral 1 shows a moving joint (moving rods, shafts, valve stems), and the numeral 2 shows a fixed joint (flanges, bonnets). The second digit shows the material of which the packing or gasket is primarily composed—*asbestos, vegetable fibre,*

*rubber, metal, and so forth.* The third and fourth digits show the different styles or forms of the packing or gasket made from the material.

Practically all shipboard packing and gasket problems can be solved by selection of the correct material from the listings on the packing and gasket chart. The following examples show the kind of information that you can get from the packing and gasket chart.

Suppose you are required to repack and install a valve in a 150-psi seawater service system. Under the subhead Symbols and Specifications for Equipments, Piping and Independent Systems, you find that symbol 1103 indicates a suitable material for repacking the valve. Notice that the first digit is the numeral 1, indicating that the material is for use in a moving joint. Under the List of Materials, you find the packing is *asbestos rod, braided.*

For installing the valve, you need proper gaskets. By use of the same subhead, you find that symbols 2150, 2151 type II, 2152, and 2290 type II are all suitable for installing the valve. Notice that the first digit is the numeral 2, which indicates that it is designed for fixed joints. Again, by referring to the List of Materials, you can determine the composition of the gasket.

Besides the Naval Ship Systems Command drawing, most ships have a packing and gasket chart made up specifically for each ship. The shipboard chart shows the symbol numbers and the sizes of packing and gaskets required in the ship's piping system, machinery, and hull fittings.

## **PACKING OF MOVING JOINTS**

Valves are components used to control the transfer of liquids and gases through fluid piping systems. Most valves have moving joints between the valve stem and the bonnet. When fluid is on one or both sides of a moving joint, the joint may leak. Sealing the joint prevents this leakage. Sealing a moving joint presents a problem because the seal must be tight enough to prevent leakage, yet loose enough to let the valve stem turn without binding. Packing is the most common method of sealing a moving joint.

Packing is a sealing method that uses bulk material (packing) that is reshaped by compression

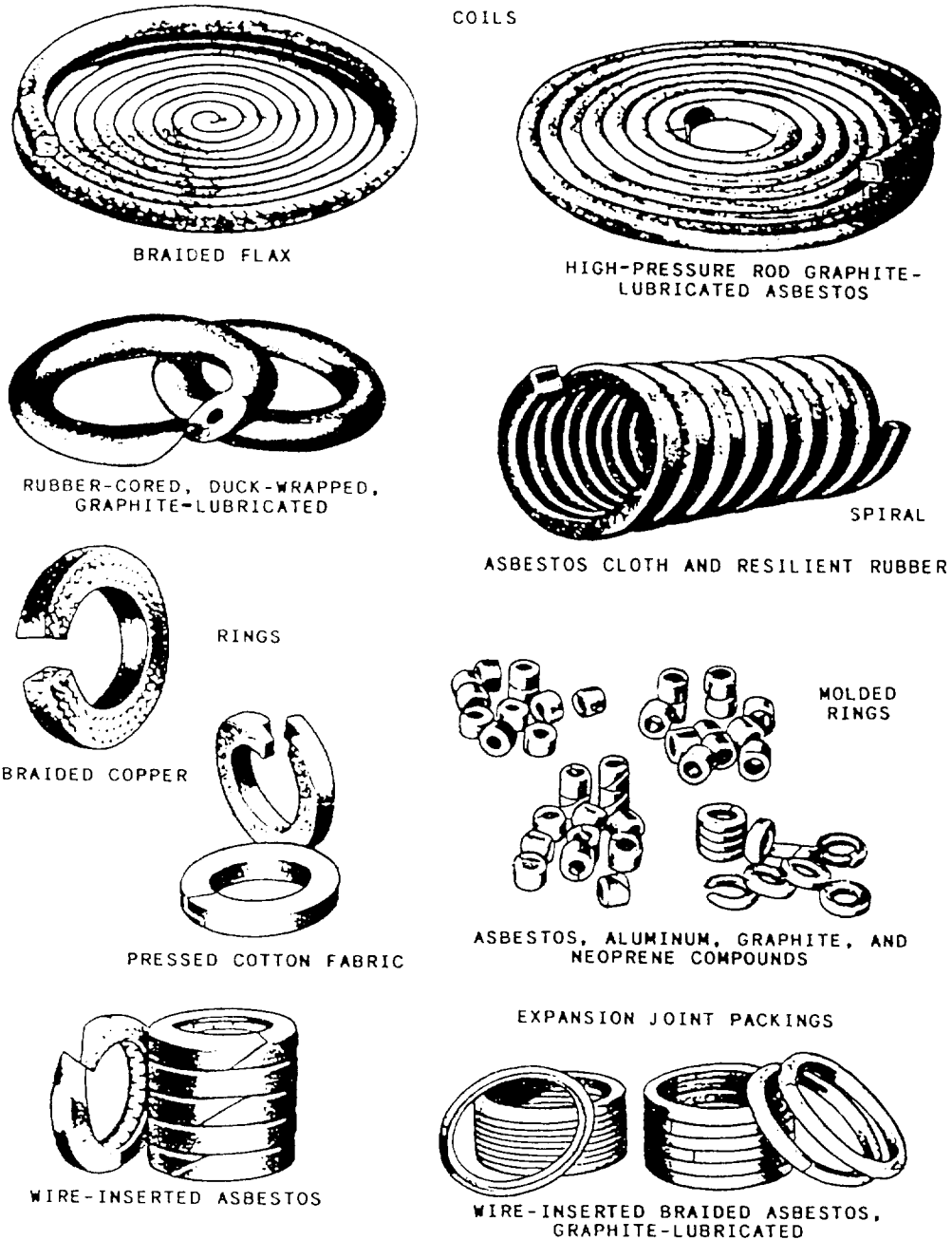

Figure 9-61.—Types of packing.

to effectively seal a moving joint. Figure 9-61 shows several types of packing in common use today.

Packing is inserted in STUFFING BOXES that have annular chambers located around valve stems and rotating shafts. The packing material is compressed to the necessary extent and held in place by gland nuts or other devices.

A corrugated ribbon packing has been developed for universal use on valves. This packing comes in four widths (1 inch, 3/4 inch, 1/2 inch, and 1/4 inch) and is easily cut to length, rolled on the valve stem, and pushed into the stuffing box to form a solid, endless packing ring when compressed (fig. 9-62). Corrugated ribbon packing is suitable for use in systems of high temperatures (up to 1200°F



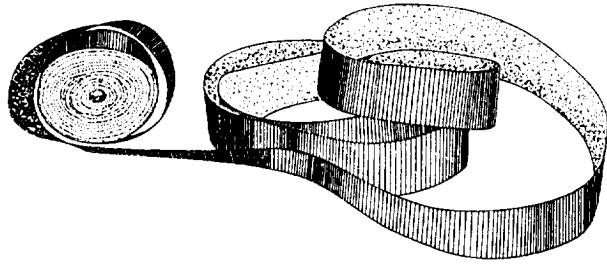

Figure 9-62.—Corrugated ribbon packing.

and 2000 psi). It is easily removed since it does not harden.

### PACKING OF FIXED JOINTS

Figure 9-63 shows gasket material used for fixed joints. At one time, fixed joints could be satisfactorily sealed with gaskets of compressed

asbestos sheet packing (view A of fig. 9-63). Today the 15 percent rubber content of the packing makes it unsatisfactory for modern, high-temperature, high-pressure equipment. Two types of gaskets (metallic or semimetallic) are in use in present day high-temperature and high-pressure installations. Gaskets of corrugated copper or of asbestos and copper are sometimes used on low- and medium-pressure lines.

Serrated-face metal gaskets (view B of fig. 9-63) made of steel, Monel, or soft iron have raised serrations to make a better seal at the piping flange joints. These gaskets have resiliency. Line pressure forces the serrated faces tighter against the adjoining flange. The gaskets shown are of two variations.

Spiral-wound, metallic-asbestos gaskets (view C of fig. 9-63) are made of interlocked strands of preformed corrugated metal and asbestos strips, spirally wound together (normally called the FILLER), and a solid metal outer or centering

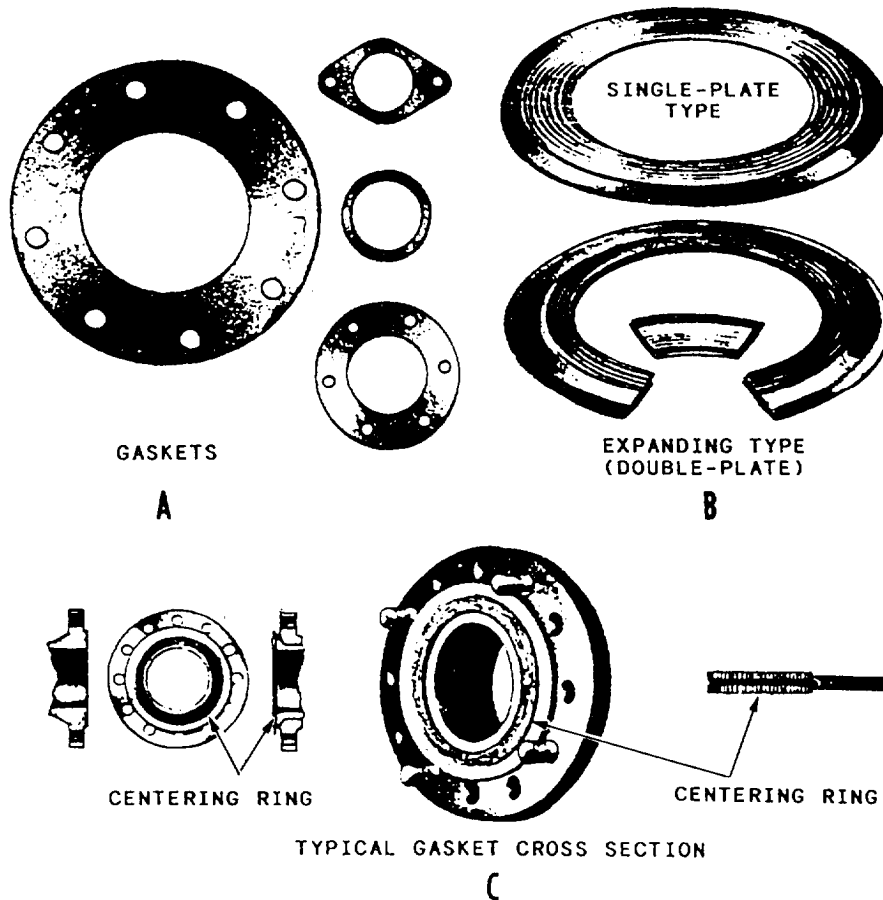

Figure 9-63.—Fixed-joint gaskets. A. Sheet asbestos gaskets. B. Serrated-face metal gaskets. C. Spiral-wound, metallic-asbestos gaskets.

ring (normally called the **RETAINING RING**). The centering ring is used as a reinforcement to prevent blowouts. The filler piece is replaceable. When renewing a gasket, you should remove this piece from the retaining metal ring and replace it with a new filler. Do not discard the solid metal retaining outer or centering ring unless it is damaged. You can compress the gaskets to the thickness of the outer or centering ring.

When renewing a gasket in a flange joint, you must exercise special precautions when breaking the joint, particularly in steam and hot water lines, or in saltwater lines that have a possibility of direct connection with the sea. Be sure to observe the following precautions:

1. No pressure is on the line.
2. The line pressure valves, including the bypass valves, are firmly secured, wired closed, and tagged.
3. The line is completely drained.
4. At least two flange-securing bolts and nuts diametrically opposite remain in place until the others are removed, then slackened to allow breaking of the joint, and removed after the line is clear.
5. Precautions are taken to prevent explosions or fire when breaking joints of flammable liquid lines.
6. Proper ventilation is ensured before joints are broken in closed compartments.

These precautions may prevent serious explosions, severe scalding of personnel, or flooding of compartments. You should thoroughly clean all sealing and bearing surfaces for the gasket replacement. Check the gasket seats with a surface plate, and scrape as necessary. This affords uniform contact. Replace all damaged bolt studs and nuts. In flange joints with raised faces, the edges of gaskets may extend beyond the edge of the raised face.

## O-RINGS

Another method of preventing leakage in fluid systems is by use of O-ring seals. Figure 9-64 shows an O-ring seal with two cross-sectional views. An O-ring is a doughnut-shaped, circular seal (view A of fig. 9-64) that is usually a molded rubber compound. An O-ring seal has an O-ring mounted in a groove or cavity (usually called a gland).

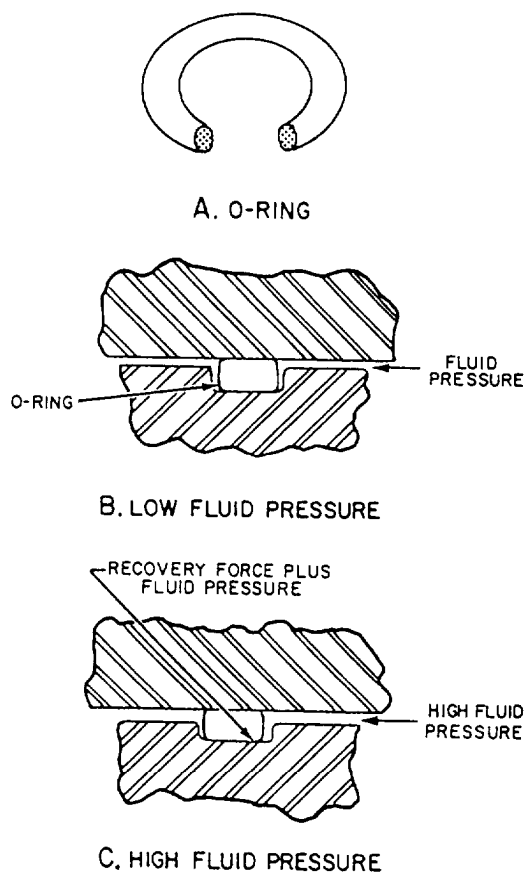

**Figure 9-64.—O-ring seal with two cross-sectional views.**

When the gland is assembled (view B of fig. 9-64), the O-ring cross section is compressed. When installed, the compression of the O-ring cross section enables it to seal low fluid pressures. The greater the compression, the greater is the fluid pressure that can be sealed by the O-ring. The pressure of the O-ring against the gland walls equals the pressure caused by the recovery force of the compressed O-ring plus the fluid pressure.

The fluid pressure against the walls of the gland and the stiffness of the O-ring prevent fluid from leaking past the O-ring. If the downstream clearance is large, the O-ring is forced into this clearance (view C of fig. 9-64). The stiffness of the O-ring material prevents the O-ring from being forced completely through the downstream clearance unless that clearance is abnormally large or the pressure is excessive.

O-rings are commonly used for sealing because of their simplicity, ruggedness, low cost, ease of installation, ease of maintenance, and effectiveness over wide pressure and temperature ranges.

Failure of an O-ring can sometimes begin with the removal of an old O-ring. If you incorrectly remove an O-ring with pointed or sharp tools, you can scratch or dent critical surface finishes that can result in seal failure.

Before installing a new O-ring, inspect the sealing surfaces for any abrasions and wipe them free of any dust, dirt, or other contaminants. Before installation, inspect the O-ring for any damage. If faulty, discard it.

When you install the O-ring, lubricate it. In most cases it is already coated with the system fluid or petrolatum grease. Do not stretch the O-ring more than twice its original size during installation, and do not roll or twist it into place. This may leave a permanent twist in the O-ring and reduce its effectiveness and shorten its life.

When installing an O-ring, take extreme care to avoid forcing it over sharp edges, corners, and threaded sections. You should use some type of sleeve or cover to avoid damaging the O-ring.

## **FASTENERS**

The proper use of fasteners is very important and cannot be overemphasized. Many shipboard machinery casualties have resulted from fasteners that were not properly installed. Machinery vibration, thermal expansion, and thermal contraction will loosen the fasteners. At sea, loosening effects are increased by the pitch and roll of the ship. You are familiar with such standard fasteners as nuts, bolts, washers, wingnuts, and screws. In this section we will discuss some of the new developments in fastener technology, such as the various types of locknuts, which you may not be familiar with.

### **THREADED LOCKING DEVICES**

An important part of fastener technology has included the development of several methods for locking mated threads of fasteners. Many of the latest methods include the locking device or method as an integral part of the fastener assembly and are referred to as self-locking nuts or bolts. Self-locking fasteners are more

expensive than some older methods but compare favorably in cost with pin or wiring methods.

### **Length of Protrusion**

Male threads on threaded fasteners, when installed and tightened, will protrude the distance of at least one thread length beyond the top of the nut or plastic locking ring. Excessive protrusion is a hazard, particularly where necessary clearances, accessibility, and safety are important. Where practicable, the number of threads protruding should not exceed five. In no case should thread protrusion exceed 10 threads unless specifically approved by the work supervisor. (This is the 1-to-10 rule.)

Where screw threads are used for setting or adjusting (such as valve stem packing glands and travel stops) or where installed threaded fasteners do not strictly follow the 1-to-10 rule but have given satisfactory service, the rule does not apply. An example of an acceptable existing installation would be where a male thread is flush with the top of a nut or where more than 10 threads protruding is of no foreseeable consequence.

### **Repair of Damaged Threads**

You can remedy damaged external threads by replacing the fastener. In large equipment castings you must repair damaged internal threads to save the part. You can repair internal threads by redrilling the damaged thread; clean and either install a solid wall insert or tap for a helical coil insert. These inserts, in effect, return the tapped hole to its original size so it takes the original mating fastener.

## **LOCKNUTS**

Locknuts are used in special applications where you want to ensure that the components joined by the fasteners will not loosen. Two types of locknuts are in common use. The first type applies pressure to the bolt thread and can be used where frequent removal may be required. The second type deforms the bolt thread and is used only where frequent removal is unnecessary. The first type includes plastic ring nuts, nylon insert nuts, jam nuts, spring nuts, and spring beam nuts. The second type includes distorted collar nuts and distorted thread nuts; they are not commonly found in gas turbine equipment and will not be covered in this section.

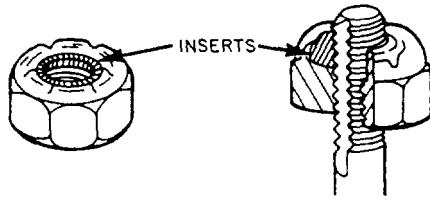

Figure 9-65.—Plastic ring nut.

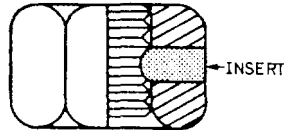

Figure 9-66.—Nylon insert nut.

### Plastic Ring Nuts

Plastic ring nuts (fig. 9-65) deform the plastic insert when they are installed. The resilient plastic material is forced to assume the shape of the mating threads, creating large frictional forces.

### Nylon Insert Nuts

Nylon insert nuts (fig. 9-66), have plastic inserts (plugs) that do not extend completely around the threads. They force the nut to the side, cocking it slightly. This produces frictional forces on one side of the bolt thread. Although the plastic insert locks without seating, proper torque applied to the nut stretches the bolt, creating clamping forces that add to the locking abilities of the nut. Before reusing nylon insert nuts, check the inserts. If worn or torn, discard the nut. Install the nut (on clean lightly lubricated threads) finger tight. If you can install the nut to the point where the bolt threads pass the insert without a wrench, discard the nut and use a new one.

### Jam Nuts

You should install jam nuts (fig. 9-67) with the thinner nut to the working surface and the thicker nut to the outside. The thin nut is deformed by the wider nut and pressed against the working surface and threads.

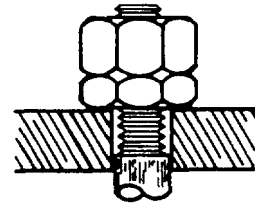

Figure 9-67.—Jam nuts.

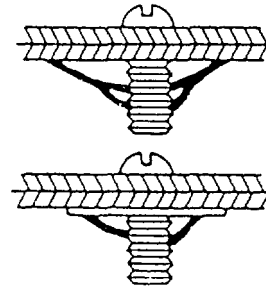

Figure 9-68.—Spring nuts.

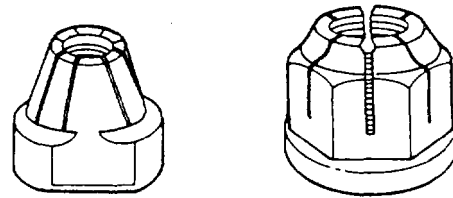

Figure 9-69.—Spring beam nuts.

### Spring Nuts

Spring nuts (fig. 9-68) lock by the side grip on the bolt. When tightened, the spring nut flattens, or straightens, a spring section. Many types of spring nuts use curved metal springs, bellows, and coil springs. All spin on and off without locking until the pressure against the working surface straightens the spring.

You should always consult equipment manuals for the proper torque value. Be sure threads are always clean and lightly lubricated with the proper lubrication. Discard any with damaged threads.

### Spring Beam Nuts

Spring beam nuts (fig. 9-69) are formed with a light taper in the threads toward the upper

portion of the nut. Slots are cut in the outer portion, forming segments that can be forced outward when the nut is installed. Elastic reaction causes the segments to push inward, gripping the bolt. Like the nylon insert nut, this nut does not deform the bolt threads and can be used on frequently removed items. If you can thread the nut past the deflection segments without a wrench, discard the nut and replace it with a new one.

## LOCKWASHERS

Many installations on board naval ships still use lockwashers to prevent threaded fasteners from loosening. If loosening has not been a problem, you may replace worn lockwashers with an identical type; however, if loosening has been a problem, you should use self-locking fasteners instead of lockwashers.

The most common lockwasher used is the helical spring washer. Other types are the conical and toothed tab.

### Helical Spring Lockwashers

The helical spring lockwasher (split ring) (fig. 9-70) is flattened when the bolt is torqued down. When torqued, it acts as a flat washer contributing normal friction for locking the screw or bolt and the working surface; it also maintains the tension on the bolt. Because of the helical spring lockwasher's small diameter, it is usually not used on soft materials or with oversized or elongated holes.

### Curved or Conical Spring Lockwashers

Curved or conical spring lockwashers have almost the same properties as the helical spring lockwasher. They provide a constant tension on the bolt or screw when loosened. The tension produced is usually less than that produced by the helical spring lockwasher. Like any locking device relying on tension, spring lockwashers may loosen on shock loading. When the bolt stretches more



Figure 9-70.—Helical spring lockwasher.

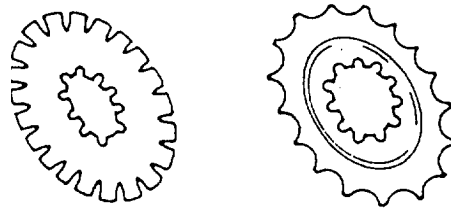

Figure 9-71.—Toothed lockwashers.

than the spring distortion from the shock loading, the washer serves no further purpose. Recheck the washer, where possible, when shock is sufficient to suspect loosening. Some spring lockwashers have teeth on the outer edge. These teeth do not aid in locking, but they prevent side slippage and turning.

### Toothed Lockwashers

Toothed lockwashers (fig. 9-71) have teeth that are twisted or bent to prevent loosening. Cutting edges engage both working surfaces on the nut and bolt or screw. Some have teeth on the inner diameter for applications where teeth projecting beyond the nut are not desired. The most common type have teeth on the outer diameter. Washers with teeth on both inside and outside diameters are used for soft materials and oversized holes. The teeth are twisted, so as the nut is installed and torqued down, the rim of the washer supports the pressure. Any backing off of the nut or bolt releases tension that allows the teeth to dig into the working surfaces of the nut and bolt.

## INSULATION

The purpose of insulation is to retard the transfer of heat FROM piping that is hotter than the surrounding atmosphere or TO piping that is cooler than the surrounding atmosphere. Insulation helps to maintain the desired temperatures in all systems. In addition, it prevents sweating of piping that carries cool or cold fluids. Insulation also serves to protect personnel from being burned by coming in contact with hot surfaces. Piping insulation represents the composite piping covering, which consists of the insulating material, lagging, and fastening. The INSULATING MATERIAL offers resistance to the flow of heat; the LAGGING, usually of painted canvas, is the protective and confining covering placed over the insulating materials; and

the FASTENING attaches the insulating material to the piping and to the lagging.

Insulation covers a wide range of temperatures, from the extremely low temperatures of the refrigerating plants to the very high temperatures of the ship's waste heat boilers. No one material could possibly be used to meet all the conditions with the same efficiency.

## INSULATION MATERIALS

The following QUALITY REQUIREMENTS for the various insulating materials are taken into consideration by the Navy in the standardization of these materials:

1. Low heat conductivity
2. Noncombustibility
3. Lightweight
4. Easy molding and installation capability
5. Moisture repellent
6. Noncorrosive, insoluble, and chemically inactive
7. Composition, structure, and insulating properties unchanged by temperatures at which it is to be used
8. Once installed, should not cluster, become lumpy, disintegrate, or build up in masses from vibration
9. Verminproof
10. Hygienically safe to handle

Insulating material is available in preformed pipe coverings, blocks, batts, blankets, and felts. Refer to *NSTM*, Chapter 635, "Thermal, Fire, and Acoustic Insulation," for detailed information on insulating materials, their application, and safety precautions.

The insulating cements are comprised of a variety of materials, differing widely among themselves as to heat conductivity, weight, and other physical characteristics. Typical of these variations are the asbestos substitute cements, diatomaceous cements, and mineral and slag wool cements. These cements are less efficient than other high-temperature insulating materials, but they are valuable for patchwork emergency repairs and for covering small irregular surfaces (valves, flanges, joints, and so forth). Additionally, the cements are used for a surface finish over block or sheet forms of insulation, to seal joints between the blocks, and to provide a smooth finish over which asbestos substitute or glass cloth lagging may be applied.

## REMOVABLE INSULATION

Removable insulation will be found on the bleed air systems and waste heat boiler systems. Removable insulation is also installed in the following locations:

- Flange pipe joints adjacent to machinery or equipment that must be broken when units are opened for inspection or overhaul
- Valve bonnets of valves larger than 2 inches internal pipe size (IPS) that operate at 300 psi and above or at 240°F and above
- All pressure-reducing and pressure-regulating valves, pump pressure governors, and strainer bonnets

## GENERAL INSULATION PRECAUTIONS

You should observe the following general precautions relative to the application and maintenance of insulation:

1. Fill and seal all air pockets and cracks. Failure to do this will cause large losses in the effectiveness of the insulation.
2. Seal the ends of the insulation and taper off to a smooth, airtight joint. At joint ends or other points where insulation is liable to be damaged, use sheet metal lagging over the insulation. You should cuff flanges and joints with 6-inch lagging.
3. Keep moisture out of all insulation work. Moisture is an enemy of heat insulation just as much as it is in electrical insulation. Any dampness increases the conductivity of all heat-insulating materials.
4. Insulate all hangers and other supports at their point of contact from the pipe or other unit they are supporting; otherwise, a considerable quantity of heat will be lost via conduction through the support.
5. Keep sheet metal covering bright and unpainted unless the protective surface has been damaged or has worn off. The radiation from bright-bodied and light-colored objects is considerably less than from rough and dark-colored objects.
6. Once installed, heat insulation requires careful inspection, upkeep, and repair. Replace lagging and insulation removed to make repairs as carefully as when originally

installed. When replacing insulation, make certain that the replacement material is of the same type as had been used originally.

7. Insulate all flanges with easily removable forms. These forms are made up as pads of insulating material, wired or bound in place, and the whole covered with sheet metal casings, which are in halves.
8. Asbestos control: Inhalation of excessive quantities of asbestos fibre or filler can produce severe lung damage in the form of disabling or fatal fibrosis of the lungs. Asbestos has also been found to be a casual factor in the development of cancer of the membrane lining the chest and abdomen. Lung damage and disease usually develop slowly and often do not become apparent until years after the initial exposure. If your plans include a long and healthy Navy retirement, you have no business doing asbestos lagging rip-out without proper training, protective clothing, and

supervision. Most systems of today's modern Navy have been purged of asbestos and an asbestos substitute material installed in its place. Some of the older class vessels may still have some asbestos insulation installed. Use caution when handling lagging and insulation from these vessels. If in doubt, contact your supervisor and request the medical department conduct a survey of the material in question.

### **SUMMARY**

This chapter has given you general information on pumps, valves, and piping. It would be a good idea to get some hands-on experience aboard your ship. Trace various systems out and see how they are set up. Ask your LPO to explain the systems and how each part in the system works. The key phrase here is ASK QUESTIONS!





## CHAPTER 10

# AUXILIARY MACHINERY AND EQUIPMENT

Ships depend on the reliability of auxiliary systems. Proper maintenance and operation of auxiliary systems will enhance the performance of main propulsion machinery. As a Fireman, you will gain a thorough knowledge of main propulsion auxiliary machinery and systems. In this chapter, we will discuss the operation of refrigeration and air-conditioning equipment, air compressors, dehydrators, distilling plants, and purifiers. Other auxiliary machinery includes the steering gear, the anchor windlass and capstan, cranes, elevators, winches, and galley and laundry equipment.

### REFRIGERATION

Most Navy refrigeration systems use R-12 as a refrigerant: Chemically, R-12 dichlorodifluoromethane (CC 1425F425). R-12 has such a low boiling point that it cannot exist as a liquid unless it is confined in a container under pressure. The cycle of operation and the main components of R-12 systems are basically the same as those in other refrigeration and air-conditioning plants.

### FUNDAMENTALS OF REFRIGERATION

*Refrigeration* is a general term. It describes the process of removing heat from spaces, objects, or materials and maintaining them at a temperature below that of the surrounding atmosphere. To produce a refrigeration effect, the material to be cooled needs only to be exposed to a colder object or environment. The heat will flow in its NATURAL direction—that is, from the warmer material to the colder material. Refrigeration, then, usually means an artificial way of lowering the temperature. Mechanical refrigeration is a mechanical system or apparatus that transfers heat from one substance to another.

It is easy to understand refrigeration if you know the relationships among temperature, pressure, and volume, and how pressure affects liquids and gases. Refer back to chapter 2 for a review.

### REFRIGERATION TON

The unit of measure for the amount of heat removed is known as the *refrigeration ton*. The capacity of a

refrigeration unit is usually stated in refrigeration tons. The refrigeration ton is based on the cooling effect of 1 ton (2,000 pounds) of ice at 32°F melting in 24 hours. The latent heat of fusion of ice (or water) is 144 Btus. Therefore, the number of Btus required to melt 1 ton of ice is  $144 \times 2,000 = 288,000$ . The standard refrigeration ton is defined as the transfer of 288,000 Btus in 24 hours. On an hourly basis, the refrigeration ton is 12,000 Btus per hour (288,000 divided by 24).

The refrigeration ton is the standard unit of measure used to designate the heat-removal capacity of a refrigeration unit. It is not a measure of the ice-making capacity of a machine, since the amount of ice that can be made depends on the initial temperature of the water and other factors.

### MECHANICAL REFRIGERATION SYSTEMS

Various types of refrigerating systems are used for naval shipboard refrigeration and air conditioning. The one usually used for refrigeration purposes is the vapor compression cycle with reciprocating compressors.

Figure 10-1 shows a general idea of this type of refrigeration cycle. As you study this system, try to understand what happens to the refrigerant as it passes through each part of the cycle. In particular, you need to understand (1) why the refrigerant changes from liquid to vapor, (2) why it changes from vapor to liquid, and (3) what happens in terms of heat because of these changes of state. In this section, the refrigerant is traced through its entire cycle, beginning with the thermostatic expansion valve (TXV).

Liquid refrigerant enters the TXV that separates the high side of the system and the low side of the system. This valve regulates the amount of refrigerant that enters the cooling coil. Because of the pressure differential as the refrigerant passes through the TXV, some of the refrigerant flashes to a vapor.

From the TXV, the refrigerant passes into the cooling coil (or evaporator). The boiling point of the refrigerant under the low pressure in the evaporator is about 20°F lower than the temperature of the space in which the cooling coil is installed. As the liquid boils

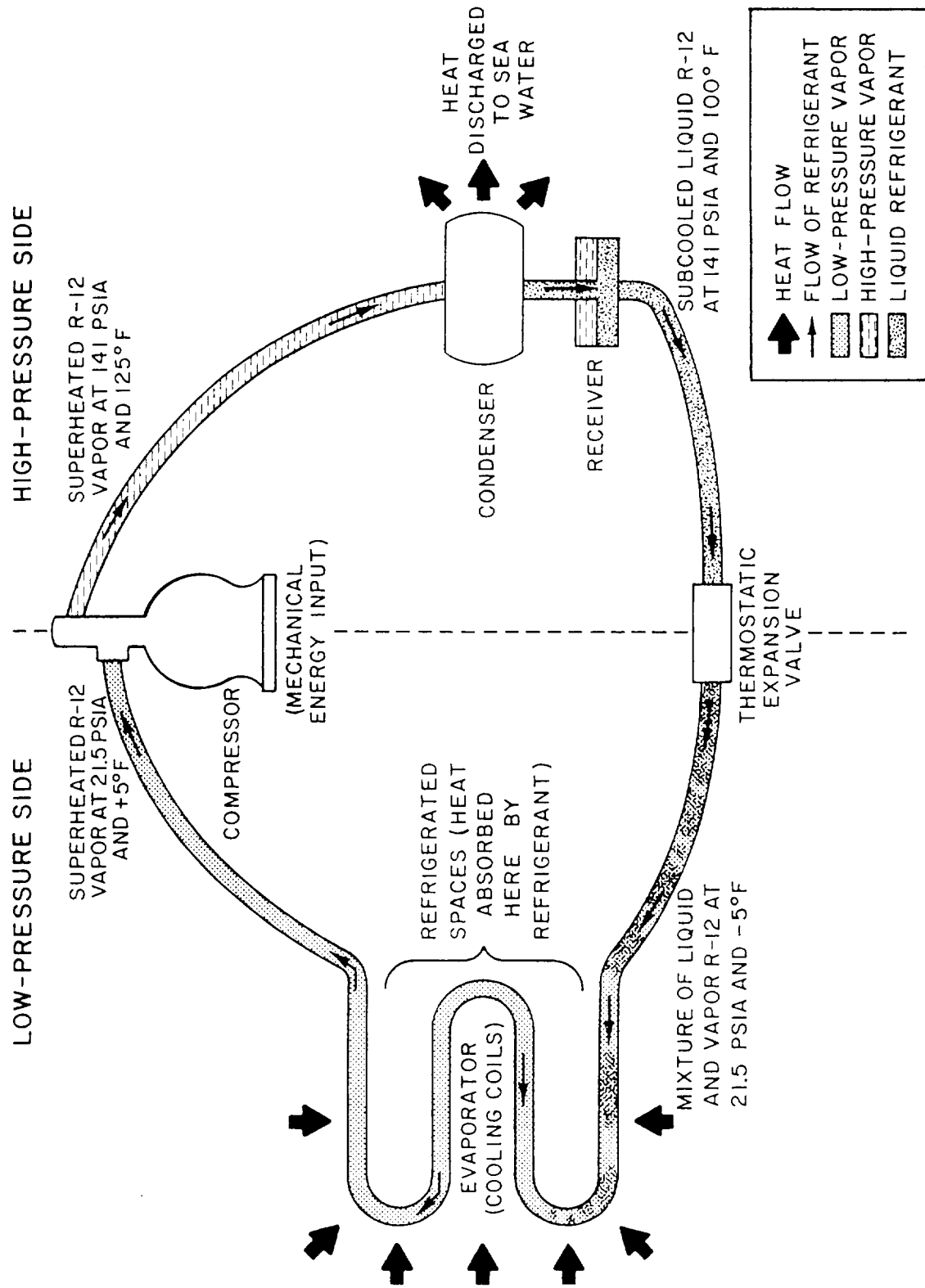

Figure 10-1.-Schematic representation of the refrigeration cycle.

and vaporizes, it picks up latent heat of vaporization from the space being cooled. The refrigerant continues to absorb latent heat of vaporization until all the liquid has been vaporized. By the time the refrigerant leaves the cooling coil, it has not only absorbed this latent heat of vaporization. It has also picked up some additional heat; that is, the vapor has become superheated. As a rule, the amount of superheat is 4° to 12°F.

The refrigerant leaves the evaporator as low-pressure superheated vapor. The remainder of the cycle is used to dispose of this heat and convert the refrigerant back into a liquid state so that it can again vaporize in the evaporator and absorb the heat again.

The low-pressure superheated vapor is drawn out of the evaporator by the compressor, which also keeps the refrigerant circulating through the system. In the compressor cylinders, the refrigerant is compressed from a low-pressure, low-temperature vapor to a high-pressure vapor, and its temperature rises accordingly.

The high-pressure R-12 vapor is discharged from the compressor into the condenser. Here the refrigerant condenses, giving up its superheat (sensible heat) and its latent heat of condensation. The condenser may be air or watercooled. The refrigerant, still at high pressure, is now a liquid again. From the condenser, the refrigerant flows into a receiver, which serves as a storage place for the liquid refrigerant in the system. From the receiver, the refrigerant goes to the TXV and the cycle begins again.

This type of refrigeration system has two pressure sides. The LOW-PRESSURE SIDE extends from the TXV up to and including the intake side of the compressor cylinders. The HIGH-PRESSURE SIDE extends from the discharge valve of the compressor to the TXV. Figure 10-2 shows most of the components on the high-pressure side of an R-12 system as it is installed aboard ship.

### MAIN PARTS OF THE R-12 SYSTEM

The main parts of an R-12 refrigeration system are shown diagrammatically in figure 10-3. The six primary components of the system include the

1. TXV,
2. evaporator,
3. capacity control system,
4. compressor,

5. condenser, and

6. receiver.

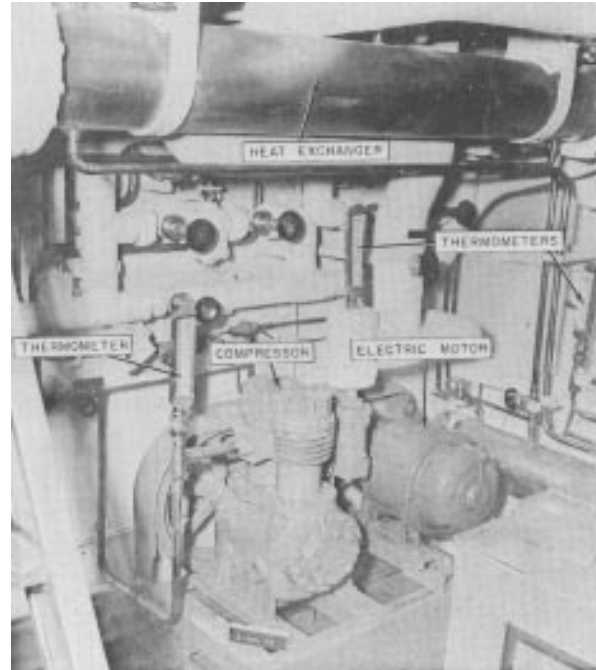

47.92

**Figure 10-2.-High-pressure side of an R-12 installation aboard ship.**

Additional equipment required to complete the plant includes piping, pressure gauges, thermometers, various types of control switches and control valves, strainer, relief valves, sight-flow indicators, dehydrators, and charging connections.

In this chapter, we will deal with the R-12 system as though it had only one evaporator, one compressor, and one condenser. As you can see from figure 10-3, however, a refrigeration system usually has more than one evaporator, and it may include an additional compressor and condenser units.

### Thermostatic Expansion Valve (TXV)

Earlier, you learned that the TXV regulates the amount of refrigerant to the cooling coil. The amount of refrigerant needed in the coil depends, of course, on the temperature of the space being cooled.

The thermal control bulb, which controls the opening and closing of the TXV, is clamped to the cooling coil near the outlet. The substance in the thermal bulb varies, depending on the refrigerant used. The expansion and contraction (because of temperature change) transmit a pressure to the diaphragm. This causes the diaphragm to be moved downward, opening

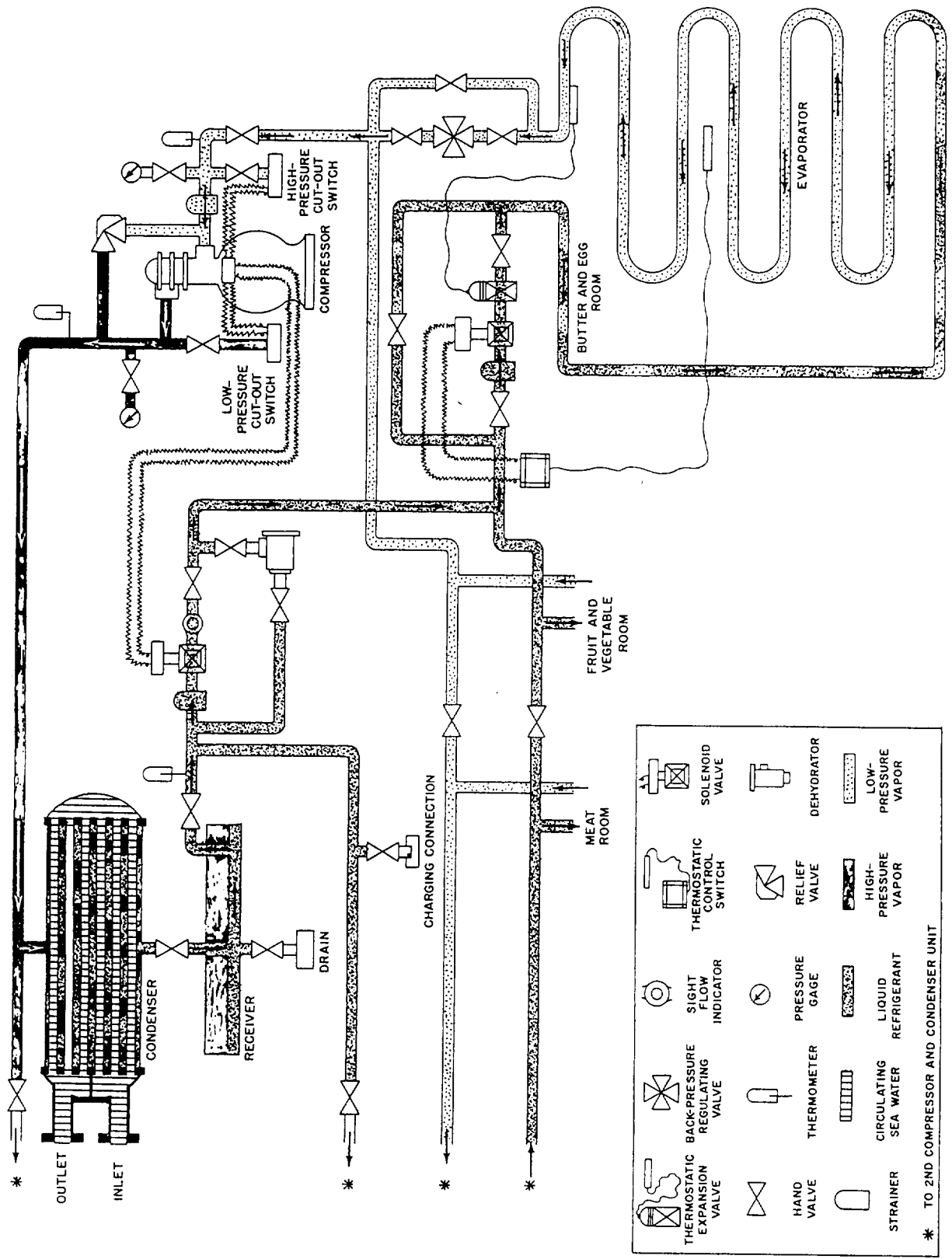

Figure 10-3.—Diagram of an R-12 refrigeration system.

the valve and allowing more refrigerant to enter the cooling coil. When the temperature at the control bulb falls, the pressure above the diaphragm decreases and the valve tends to close. Thus, the temperature near the evaporator outlet controls the operation of the TXV.

### **Evaporator**

The evaporator consists of a coil of copper, aluminum, or aluminum alloy tubing installed in the space to be refrigerated. Figure 10-4 shows some of this tubing. As mentioned before, the liquid R-12 enters the tubing at a reduced pressure and, therefore, with a lower boiling point. As the refrigerant passes through the evaporator, the heat flowing to the coil from the surrounding air causes the rest of the liquid refrigerant to boil and vaporize. After the refrigerant has absorbed its latent heat of vaporization (that is, after it is entirely vaporized), the refrigerant continues to absorb heat until it becomes superheated by

approximately 10°F. The amount of superheat is determined by the amount of liquid refrigerant admitted to the evaporator. This, in turn, is controlled by the spring adjustment of the TXV. A temperature range of 4° to 12°F of superheat is considered desirable. It increases the efficiency of the plant and evaporates all of the liquid. This prevents liquid carry-over into the compressor.

### **Compressor**

The compressor in a refrigeration system is essentially a pump. It is used to pump heat uphill from the cold side to the hot side of the system. The heat absorbed by the refrigerant in the evaporator must be removed before the refrigerant can again absorb latent heat. The only way the vaporized refrigerant can be made to give up the latent heat of vaporization that it absorbed in the evaporator is by cooling and condensing it. Because of the relatively high

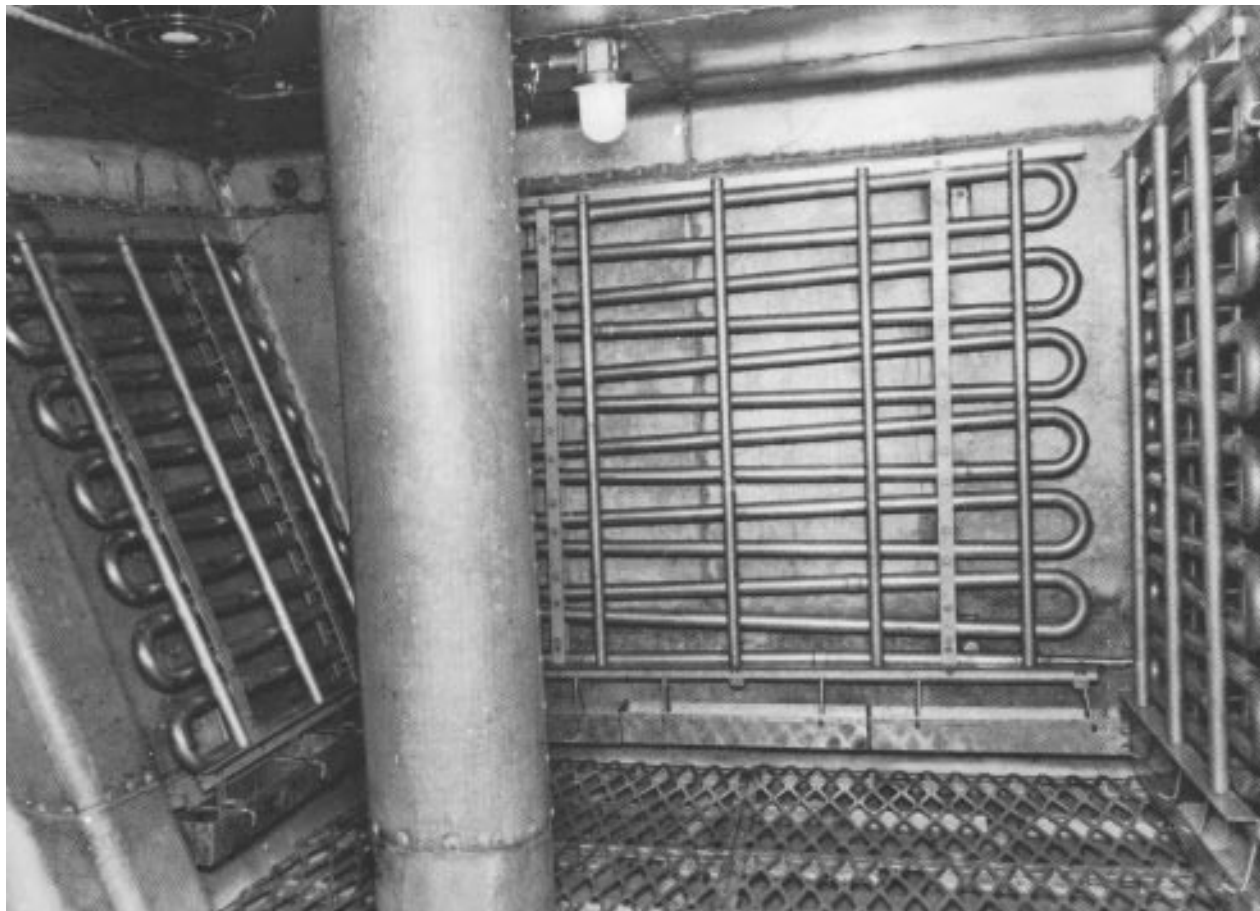

**Figure 10-4.-Evaporator tubing.**

**47.93**

temperature of the available cooling medium, the only way to make the vapor condense is to compress it.

When we raise the pressure, we also raise the temperature. Therefore, we have raised its condensing temperature, which allows us to use seawater as a cooling medium in the condenser. In addition to this primary function, the compressor also keeps the refrigerant circulating and maintains the required pressure difference between the high-pressure and low-pressure sides of the system.

Many different types of compressors are used in refrigeration systems. The designs of compressors vary depending on the application of the refrigerants used in the system. Figure 10-5 shows a motor-driven, single-acting, two-cylinder, reciprocating compressor, such as those commonly used in naval refrigeration plants.

Compressors used in R-12 systems may be lubricated either by splash lubrication or by pressure

lubrication. Splash lubrication, which depends on maintaining a fairly high oil level in the compressor crankcase, is usually satisfactory for smaller compressors. High-speed or large-capacity compressors use pressure lubrications systems.

### Capacity Control System

Most compressors are equipped with an oil-pressure-operated automatic capacity control system. This system unloads or cuts cylinders out of operation following decreases in the refrigerant load requirements of the plant. A cylinder is unloaded by a mechanism that holds the suction valve open so that no gas can be compressed.

Since oil pressure is required to load or put cylinders into operation, the compressor will start with all controlled cylinders unloaded. But as soon as the compressor comes up to speed and full oil pressure is developed, all cylinders will become operative. After

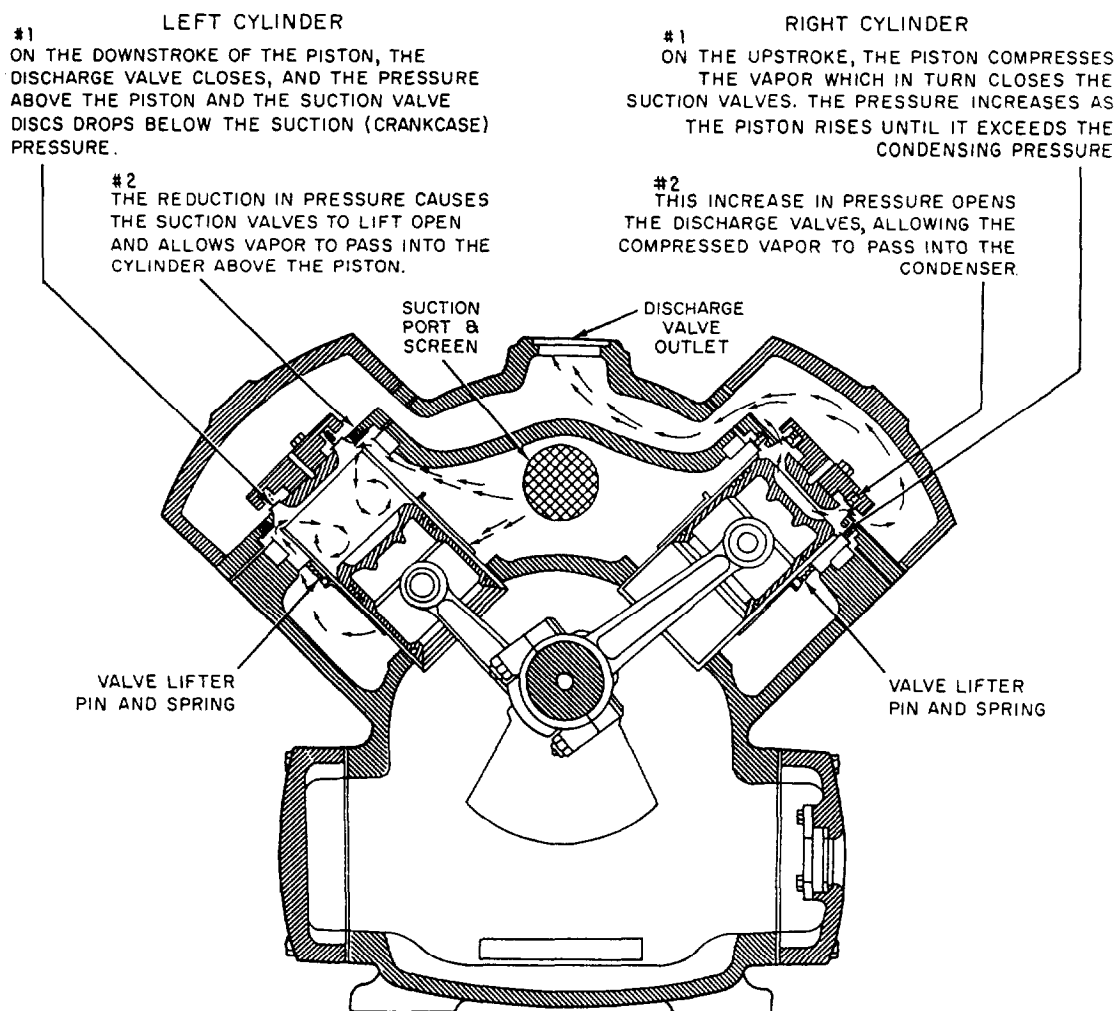

Figure 10-5. Reciprocating compressor.

the temperature pull-down period, the refrigeration load imposed on the compressor will decrease, and the capacity control system will unload cylinders accordingly. The unloading will result in reduced power consumption. On those applications where numerous

cooling coils are supplied by one compressor, the capacity control system will prevent the suction pressure from dropping to the low-pressure cutout setting. This will prevent stopping the compressor before all solenoid valves are closed.

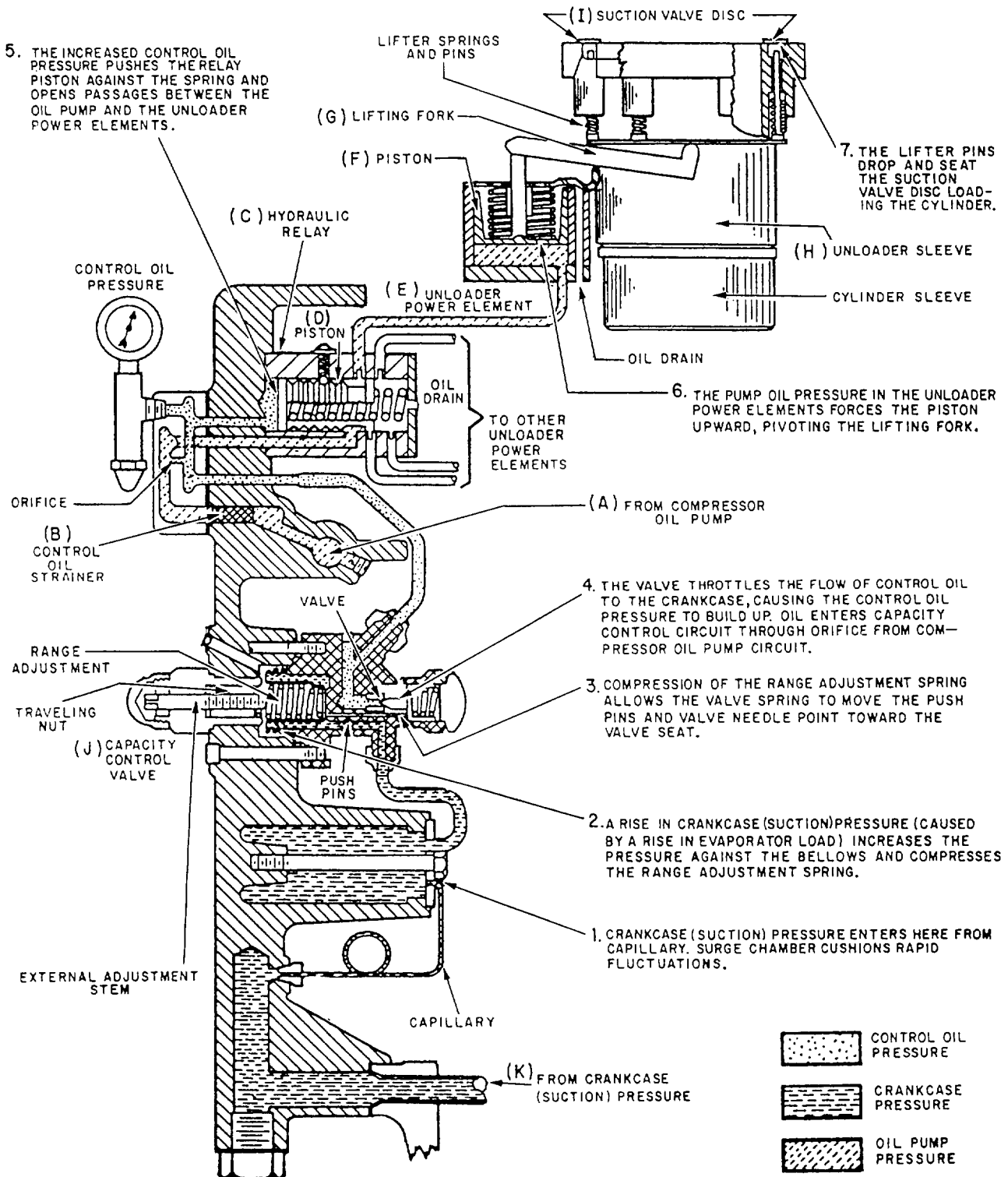

Figure 10-6.-Capacity control system.

Several designs of capacity control systems are in use. One of the most common is shown in figure 10-6. The capacity control system consists of a power element and its link for each controlled cylinder, a step control hydraulic relay, and a capacity control valve.

The system's components are all integrally attached to the compressor. The suction or crankcase pressure of the refrigeration plant is sensed by the capacity control valve to control the system. In other words, a change in the refrigeration load on the plant will cause a change in suction pressure. This change in suction pressure will then cause the capacity control system to react according to whether the suction pressure increased or decreased. The working fluid of the system is compressor oil pump pressure. Compressor oil pump pressure is metered into the system through an orifice. Once the oil passes the orifice, it becomes the system control oil and does work.

Locate the following components on figure 10-6, and refer to them as you read the next two paragraphs.

- (A) Compressor oil pump pressure tap-off
- (B) Control oil strainer
- (C) Hydraulic relay
- (D) Hydraulic relay piston
- (E) Unloader power element
- (M) Unloader power element piston
- (G) Lifting fork
- (H) Unloader sleeve
- (O) Suction valve
- (J) Capacity control valve
- (K) Crankcase (suction) pressure sensing point

The following functions take place when the compressor is started with a warm load on the refrigeration system.

Compressor oil (A) is pumped through the control oil strainer (B) into the hydraulic relay (C). There the oil flow to the unloader power elements is controlled in steps by the movement of the hydraulic relay piston (D). As soon as pump oil pressure reaches a power element (E), the piston (F) rises, the lifting fork (G) pivots, and the unloader sleeve (H) lowers, permitting the suction valve (1) to seat. The system is governed by suction pressure, which actuates the capacity control valve (J). This valve controls the movement of the hydraulic relay piston by metering the oil bleed from the control oil side of the hydraulic relay back to the crankcase.

Suction pressure increases or decreases according to increases or decreases in the refrigeration load requirements of the plant. After the temperature pulldown period with a subsequent decrease in suction pressure, the capacity control valve moves to increase the control oil bleed to the crankcase from the hydraulic relay. There is a resulting decrease in control oil pressure within the hydraulic relay. This decrease allows the piston to be moved by spring action. This action successively closes oil ports and prevents compressor oil pump pressure from reaching the unloader power elements. As oil pressure leaves a power element, the suction valve rises and that cylinder unloads. With an increase in suction pressure, this process is reversed, and the controlled cylinders will load in succession. The loading process is detailed in steps 1 through 7 in figure 10-6.

### Condenser

The compressor discharges the high-pressure, high-temperature refrigerant vapor to the condenser, where it flows around the tubes through which seawater is being pumped. As the vapor gives up its superheat (sensible heat) to the seawater, the temperature of the vapor drops to the condensing point. The refrigerant, now in liquid form, is subcooled slightly below its condensing point. This is done at the existing pressure to ensure that it will not flash into vapor.

A water-cooled condenser for an R-12 refrigeration system is shown in figure 10-7. Circulating water is obtained through a branch connection from the fire main or by means of an individual pump taking suction from the sea. The purge connection (fig. 10-7) is on the refrigerant side. It is used to remove air and other noncondensable gases that are lighter than the R-12 vapor.

Most condensers used for naval refrigeration plants are of the water-cooled type. However, some small units have air-cooled condensers. These consist of tubing with external fins to increase the heat transfer surface. Most air-cooled condensers have fans to ensure positive circulation of air around the condenser tubes.

### Receiver

The receiver (fig. 10-8) acts as a temporary storage space and surge tank for the liquid refrigerant. The receiver also serves as a vapor seal to keep vapor out of the liquid line to the expansion valve. Receivers are constructed for either horizontal or vertical installation.



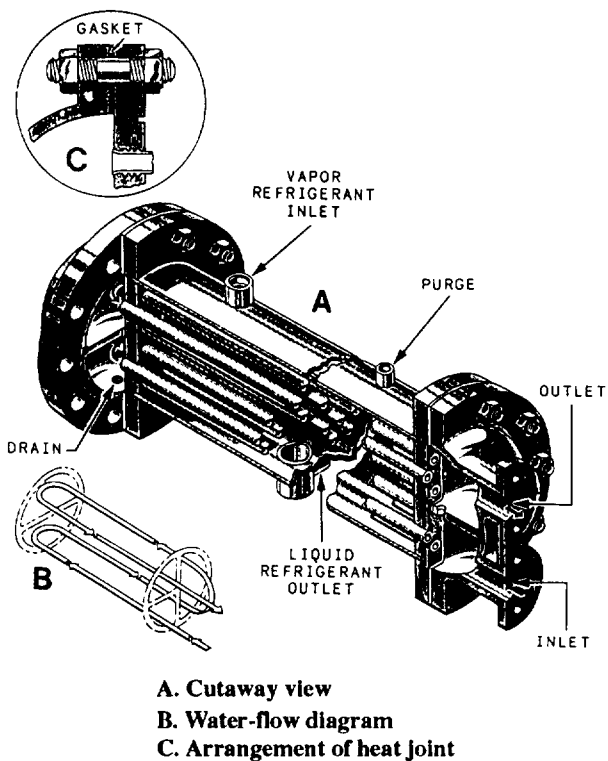

Figure 10-7.-Water-cooled condenser for an R-12 refrigeration system.

## ACCESSORIES

In addition to the five main components of a refrigeration system, a number of controls and accessories are required. The most important of these are described briefly in the following paragraphs.

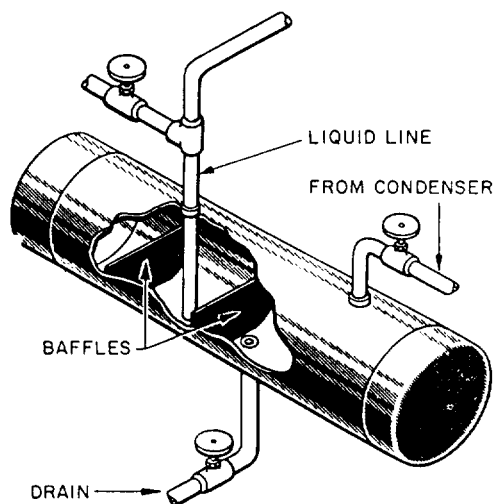

Figure 10-8.-Receiver.

## Dehydrator

A dehydrator, or dryer, containing silica gel or activated alumina, is placed in the liquid refrigerant line between the receiver and the TXV. In older installations, bypass valves allow the dehydrator to be cut in or out of the system. In newer installations, the dehydrator is installed in the liquid refrigerant line without any bypass arrangement. A dehydrator is shown in figure 10-9.

## Moisture Indicator

A moisture indicator is located either in the liquid refrigerant line or built into the dehydrator. The moisture indicator contains a chemically treated element that changes color when there is an increase of moisture in the refrigerant. The color change is reversible and changes back to a DRY reading when the moisture is removed from the refrigerant. Excessive moisture or water will damage the moisture indicator element and turn it gray, which indicates it must be replaced.

## Solenoid Valve and Thermostatic Control Switch

A solenoid valve is installed in the liquid line leading to each evaporator. Figure 10-10 shows a solenoid valve and the thermostatic control switch that operates it. The thermostatic control switch is connected by long flexible tubing to a thermal control bulb located in the refrigerated space. When the temperature in the refrigerated space drops to the desired point, the thermal control bulb causes the thermostatic control switch to

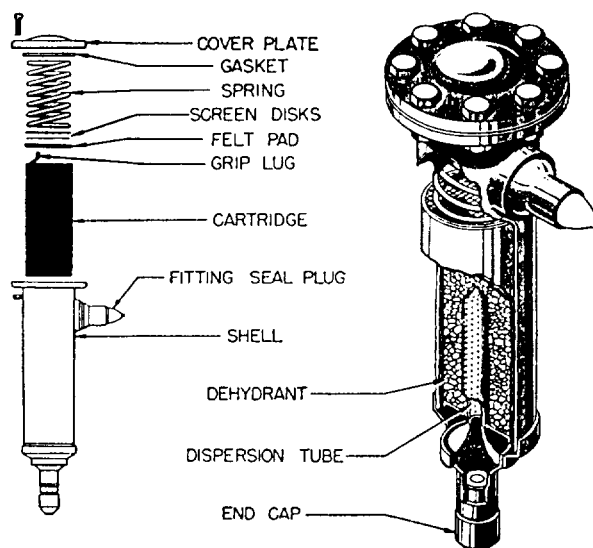

Figure 10-9.-Refrigeration dehydrator.

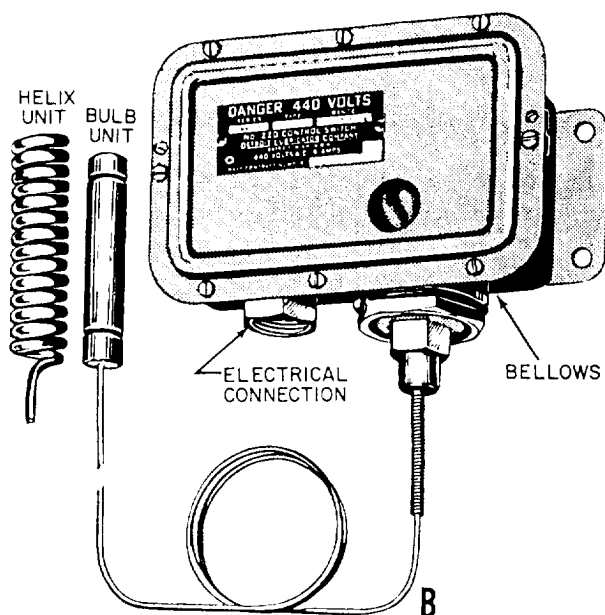
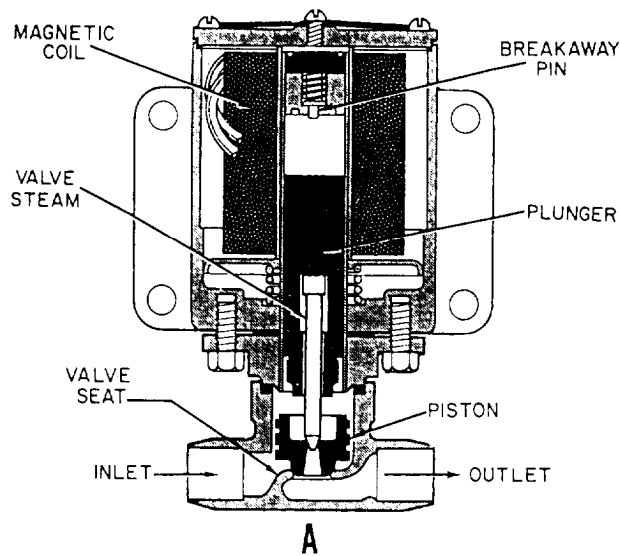

Figure 10-10. Solenoid valve and thermostatic control switch.

open. This action closes the solenoid valve and shuts off all flow of liquid refrigerant to the TXV. When the temperature in the refrigerated space rises above the desired point, the thermostatic control switch closes, the solenoid valve opens, and liquid refrigerant once again flows to the TXV.

The solenoid valve and its related thermostatic control switch maintain the proper temperature in the refrigerated space. You may wonder why the solenoid valve is necessary if the TXV controls the amount of refrigerant admitted to the evaporator. Actually, the solenoid valve is not necessary on units that have only one evaporator. In systems that have more than one

evaporator and where there is wide variation in load, the solenoid valve provides additional control to prevent the spaces from becoming too cold at light loads.

In addition to the solenoid valve installed in the line to each evaporator, a large refrigeration plant usually has a main liquid line solenoid valve installed just after the receiver. If the compressor stops for any reason except normal suction pressure control, the main liquid solenoid valve closes. This prevents liquid refrigerant from flooding the evaporator and flowing to the compressor suction. Extensive damage to the compressor can result if liquid is allowed to enter the compressor suction.

### Evaporator Pressure Regulating Valve

In some ships, several refrigerated spaces of varying temperatures are maintained by one compressor. In these cases, an evaporator pressure regulating valve is installed at the outlet of each evaporator EXCEPT the evaporator in the space in which the lowest temperature is to be maintained. The evaporator pressure regulating valve is set to keep the pressure in the coil from falling below the pressure corresponding to the lowest evaporator temperature desired in that space. The evaporator pressure regulating valve is used

- on water coolers,
- on units where high humidity is required (such as fruit and vegetable stow spaces), and
- in installations where two or more rooms are maintained at different temperatures by the use of the same refrigeration unit.

A cross section of a common evaporator pressure regulating valve (commonly called the EPR valve) is shown in figure 10-11. The tension of the spring above the diaphragm is adjusted so that when the evaporator coil pressure drops below the desired minimum, the spring will shut the valve.

The EPR valve is not really a temperature control; that is, it does not regulate the temperature in the space. It is only a device to prevent the temperature from becoming too low.

### Low-Pressure Cutout Switch

The low-pressure cutout switch is also known as a *suction pressure control switch*. This switch is the control that causes the compressor to go on or off as required for normal operation of the refrigeration plant.

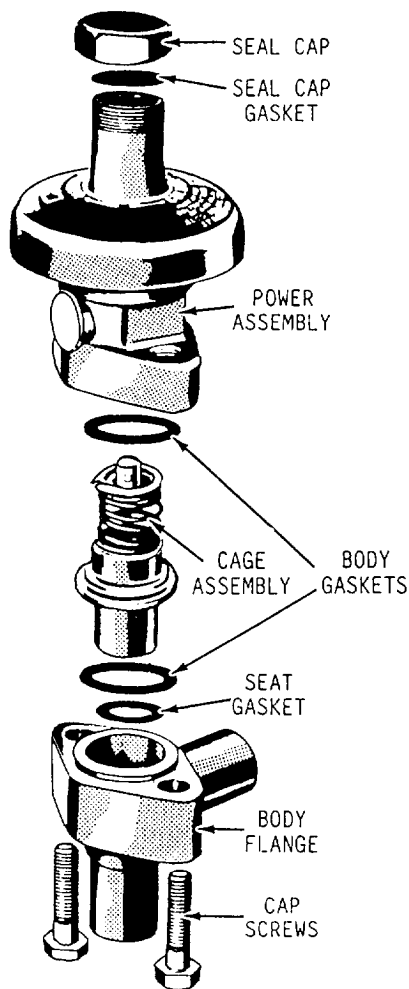

**Figure 10-11.-Exploded view of a typical evaporator pressure regulating valve.**

It is located on the suction side of the compressor and is actuated by pressure changes in the suction line.

When the solenoid valves in the lines to the various evaporators are closed, the flow of refrigerant to the evaporators is stopped. This action causes the pressure of the vapor in the compressor suction line to drop quickly. When the suction pressure has dropped to the desired pressure, the low-pressure cutout switch stops the compressor motor. When the temperature in the refrigerated spaces rises enough to operate one or more of the solenoid valves, refrigerant is again admitted to the cooling coils. This causes the compressor suction pressure to buildup again. At the desired pressure, the low-pressure cutout switch closes, starting the compressor, and the cycle is repeated again.

### High-Pressure Cutout Switch

A high-pressure cutout switch is connected to the compressor discharge line to protect the high-pressure

side of the system against excessive pressures. The design of this switch is essentially the same as that of the low-pressure cutout switch. However, the low-pressure cutout switch is made to CLOSE when the suction pressure reaches its upper normal limit, while the high-pressure cutout switch is made to OPEN when the discharge pressure is too high. As you already have learned, the low-pressure cutout switch is the compressor control for the normal operation of the plant. On the other hand, the high-pressure cutout switch is a safety device only. **It does not have control of the compressor under normal conditions.**

### Water Failure Switch

A water failure switch stops the compressor if there is a circulating water supply failure. The water failure switch is a pressure-actuated switch. Its operation is similar to the low- and high-pressure cutout switches previously described. If the water failure cutout switch fails to function, the refrigerant pressure in the condenser quickly builds up to the point that the high-pressure switch stops the compressor.

### Strainer

Because of the solvent action of R-12, any particles of grit, scale, dirt, or metal that the system may contain are circulated through the refrigerant lines. To avoid damaging the compressor from foreign matter, a strainer is installed in the compressor suction connection.

### Water Regulating Valve

A water regulating valve controls the quantity of circulating water flowing through the refrigerant condenser. The water regulating valve is actuated by the refrigerant pressure in the compressor discharge line. This pressure acts upon a diaphragm (or, in some valves, a bellows arrangement) that transmits motion to the valve stem.

The primary function of the water regulating valve is to maintain a constant refrigerant condensing pressure. Basically, the following two variable conditions exist:

1. The amount of refrigerant to be condensed
2. Changing water temperatures

The valve maintains a constant refrigerant condensing pressure by controlling the water flow through the condenser. By sensing the refrigerant pressure, the valve permits only enough water through

the condenser to condense the amount of refrigerant vapor coming from the compressor. The quantity of water required to condense a given amount of refrigerant varies with the water temperature. Thus, the flow of cooling water through the condenser is automatically maintained at the rate actually required to condense the refrigerant under varying conditions of load and temperature.

### Pressure Gauges and Thermometers

A number of pressure gauges and thermometers are used in refrigeration systems. Figure 10-12 shows a compound R-12 gauge. The temperature markings on this gauge show the boiling point (or condensing point) of the refrigerant at each pressure; the gauge cannot measure temperature directly. The red pointer is a stationary marker that can be set manually to indicate the maximum working pressure.

A water pressure gauge is installed in the circulating water line to the condenser to indicate failure of the circulating water supply.

Standard thermometers of appropriate range are provided for the refrigerant system.

### CHARACTERISTICS OF REFRIGERANTS

Pure R-12 (CC 1425F425) is colorless. It is odorless in concentrations of less than 20 percent by volume in air. In higher concentrations, its odor resembles that of carbon tetrachloride. It has a boiling point of  $-21^{\circ}\text{F}$  at atmospheric pressure. At ordinary temperatures under a pressure of approximately 70 psig to 75 psig, R-12 is a

liquid. Because of R-12's low boiling point at atmospheric pressure, you must always protect your eyes from contact with liquid R-12; the liquid will freeze the tissues of the eyes. Always wear goggles if you are to be exposed to R-12. R-22 (CHC1F425) and R-11 (CC1435F) are colorless, nonexplosive, nonpoisonous refrigerants with many properties similar to those of R-12. Because of the similarities between R-22, R-11, and R-12, only R-12 is discussed.

Mixtures of R-12 vapor and air, in all proportions, will not irritate your eyes, nose, throat, or lungs. The refrigerant will not contaminate or poison foods or other supplies with which it may come in contact. The vapor is nonpoisonous. However, if R-12 concentration becomes excessive, it can cause you to become unconscious or cause death because of lack of oxygen to the brain.

R-12 is nonflammable and nonexplosive in either a liquid or vapor state. R-12 will not corrode the metals commonly used in refrigerating systems.

R-12 is a stable compound capable of undergoing the physical changes required of it in refrigeration service without decomposing. It is an excellent solvent and has the ability to loosen and remove all particles of dirt, scale, and oil with which it comes in contact within a refrigerating system.

### HALOCARBONS

HaloCarbons are organic chemical compounds containing hydrogen and one or more atoms of carbon, fluorine, bromine, chlorine, or iodine. These elements may be present in various combinations in the compound.

### WARNING

Refrigerants are halocarbons. Personnel working with refrigerants may be injured or killed if proper precautions are not taken.

You may be more familiar with the brand names of halocarbons, such as Freon(s) (refrigerants), Gentron, Gension D., Frigen, AFFF, or Carbon Tetrachloride. You will work with these compounds regularly aboard ship. Because you use them frequently, you gain a false sense of security that makes you forget their potential for danger. Halocarbons are especially dangerous when used in high concentration in confined or poorly ventilated spaces.

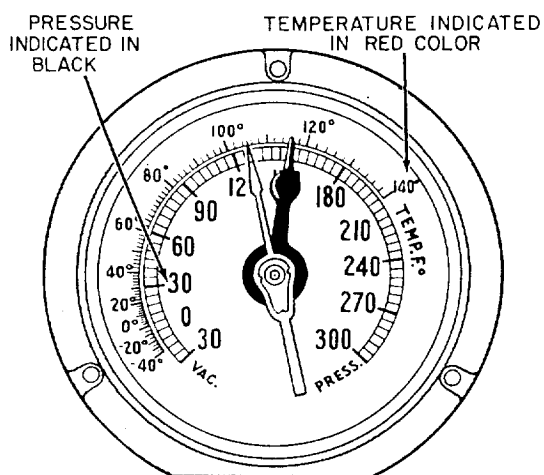

Figure 10-12.-Compound R-12 pressure gauge.

## PERSONAL SAFETY PRECAUTIONS

R-12 is a powerful freezing agent. Even a very small amount can freeze the delicate tissues of the eye, causing permanent damage. All personnel must wear goggles when working in spaces where they may be exposed to a refrigerant, particularly in its liquid form. If refrigerant does get into someone's eyes, get that person **IMMEDIATE** medical treatment to avoid permanent damage. In the meantime, put drops of clean olive oil, mineral oil, or other nonirritating oil in the eyes. Make sure that the person does not rub his/her eyes.

### CAUTION

Do NOT use anything except clean, nonirritating oil for this type of eye injury.

If R-12 comes in contact with the skin, it may cause frostbite. This injury should be treated as any other cause of frostbite. Immerse the affected part in a warm bath for about 10 minutes, then dry carefully. Do not rub or massage the affected area.

Know, understand, and use these safety precautions, and you can safely operate and maintain refrigeration plants.

## HANDLING OF REFRIGERANT CYLINDERS (BOTTLES)

Refrigerants are furnished in cylinders for use in shipboard refrigeration systems. The following precautions **MUST BE OBSERVED** in the handling, use, and storage of these cylinders:

**NOTE:** Before handling refrigerant bottles, read OPNAVINST 5100.19.

1. NEVER drop cylinders nor permit them to strike each other violently.
2. NEVER use a lifting magnet or a sling (rope or chain) when you handle cylinders. A crane may be used if a safe cradle or platform is provided to hold the cylinders.
3. Keep the caps provided for valve protection on cylinders except when the cylinders are being used.
4. When refrigerant is discharged from a cylinder, weigh the cylinder immediately. Record the weight of the refrigerant remaining in the cylinder.
5. NEVER attempt to mix gases in a cylinder.

6. NEVER PUT THE WRONG REFRIGERANT INTO A REFRIGERATION SYSTEM! **NO REFRIGERANT EXCEPT THE ONE FOR WHICH A SYSTEM WAS DESIGNED SHOULD EVER BE INTRODUCED INTO THE SYSTEM.** Check the equipment nameplate or the manufacturer's technical manual to determine the proper refrigerant type and charge. Putting the wrong refrigerant into a system may cause a violent explosion.

7. When a cylinder is empty, close the cylinder valve immediately to prevent the entrance of air, moisture, or dirt. Also, replace the valve protection cap.

8. NEVER use cylinders for other than their intended purpose. Do NOT use them as rollers and supports.

9. Do NOT tamper with the safety devices in the valves or cylinders.

10. Open cylinder valves slowly. NEVER use wrenches or other tools except those provided by the manufacturer.

11. Be sure the threads on regulators or other connections are the same as those on the cylinder valve outlets. NEVER force connections that do not fit.

12. Regulators and pressure gauges provided for use with a particular gas must NOT be used on cylinders containing other gases.

13. NEVER attempt to repair or alter cylinders or valves.

14. NEVER fill R-12 cylinders beyond 85 percent capacity.

15. Store cylinders in a cool, dry place, in an UPRIGHT position. If the cylinders are exposed to excessive heat, a dangerous increase in pressure will occur. If cylinders must be stored in the open, protect them against extremes of weather. NEVER store a cylinder in an area where the temperature will be above 125°F.

**16. NEVER ALLOW R-12 TO COME IN CONTACT WITH A FLAME OR RED-HOT METAL!** When exposed to excessively high temperatures, R-12 breaks down into phosgene gas, an extremely poisonous substance.

## AIR CONDITIONING

Air conditioning is a field of engineering that deals with the design, construction, and operation of equipment used to establish and maintain desirable

indoor air conditions. It is used to maintain the environment of an enclosure at any required temperature, humidity, and purity. Simply stated, air conditioning involves the cooling, heating, dehumidifying, ventilating, and purifying of air.

One of the chief purposes of air conditioning aboard ship is to keep the crew comfortable, alert, and physically fit. None of us can long maintain a high level of efficiency under adverse environmental conditions. We have to maintain a variety of compartments at a prescribed temperature with proper circulation. These compartments must have the proper moisture content, the correct proportion of oxygen, and an acceptable level of air contamination (dust, airborne dirt, etc.). We also have to provide mechanical cooling or ventilation in ammunition spaces to prevent deterioration of ammunition components. We have to provide them in gas storage spaces to prevent excessive pressure buildup in containers and contamination in the space caused by gas leaks. Finally, we must provide cooling and ventilation in electrical/electronic equipment spaces. This is done to maintain the ambient temperature and humidity, as specified for the equipment.

To properly air-condition a space, the humidity, heat of the air, temperature, body heat balance, the effect of air motion, and the sensation of comfort is considered.

## HEAT OF AIR

The heat of air is considered from three standpoints—sensible, latent, and total heat.

**SENSIBLE HEAT** is the amount of heat, which, when added to or removed from air, changes the temperature of the air. Sensible heat changes can be measured by the common (dry-bulb) thermometer,

Air always contains some water vapor. Any water vapor in the air contains the **LATENT HEAT OF VAPORIZATION**. (The amount of latent heat present has no effect on temperature and it cannot be measured with a dry-bulb thermometer.)

Any mixture of dry air and water vapor contains both sensible and latent heat. The sum of the sensible heat and the latent heat in any sample of air is called the **TOTAL HEAT** of the air.

## TEMPERATURES

To test the effectiveness of air-conditioning equipment and to check the humidity of a space, you must consider two different temperatures—the dry-bulb and wet-bulb temperature.

## Measurement of Temperatures

The **DRY-BULB TEMPERATURE** is the temperature of sensible heat of the air, as measured by an ordinary thermometer. In air conditioning, such a thermometer is known as a *dry-bulb thermometer* because its sensing bulb is dry.

The **WET-BULB TEMPERATURE** is best explained by a description of a wet-bulb thermometer. It is an ordinary thermometer with a loosely woven cloth sleeve or wick placed around its bulb and which is then wet with distilled water. The water in the sleeve or wick is evaporated by a current of air at high velocity (see next paragraph). This evaporation withdraws heat from the thermometer bulb, lowering the temperature by several degrees. The difference between the dry-bulb and the wet-bulb temperatures is called the *wet-bulb depression*. When the wet-bulb temperature is the same as the dry-bulb, the air is said to be saturated; that is, evaporation cannot take place. The condition of saturation is unusual, however, and a wet-bulb depression is normally expected.

The wet-bulb and dry-bulb thermometers are usually mounted side by side on a frame that has a handle and a short chain attached. This allows the thermometers to be whirled in the air, providing a high-velocity air current to promote evaporation. Such a device is known as a **SLING PSYCHROMETER** (fig. 10- 13). When using the sling psychrometer, whirl it rapidly—at least four times per second. Observe the wet-bulb temperature at intervals. The Point at which there is no further drop in temperature is the wet-bulb temperature for that space.

**MOTORIZED PSYCHROMETERS** (fig. 10- 14) are provided with a small motor-driven fan and dry-cell batteries. Motorized psychrometer are generally preferred and are gradually replacing sling psychrometer.

## Relationships Between Temperatures

You should clearly understand the definite relationships of the three temperatures—dry-bulb, wet-bulb, and dew-point.

When air contains some moisture but is not saturated, the dewpoint temperature is lower than the dry-bulb temperature; the wet-bulb temperature lies between them. As the amount of moisture in the air increases, the difference between the dry-bulb temperature and the wet-bulb temperature becomes less.

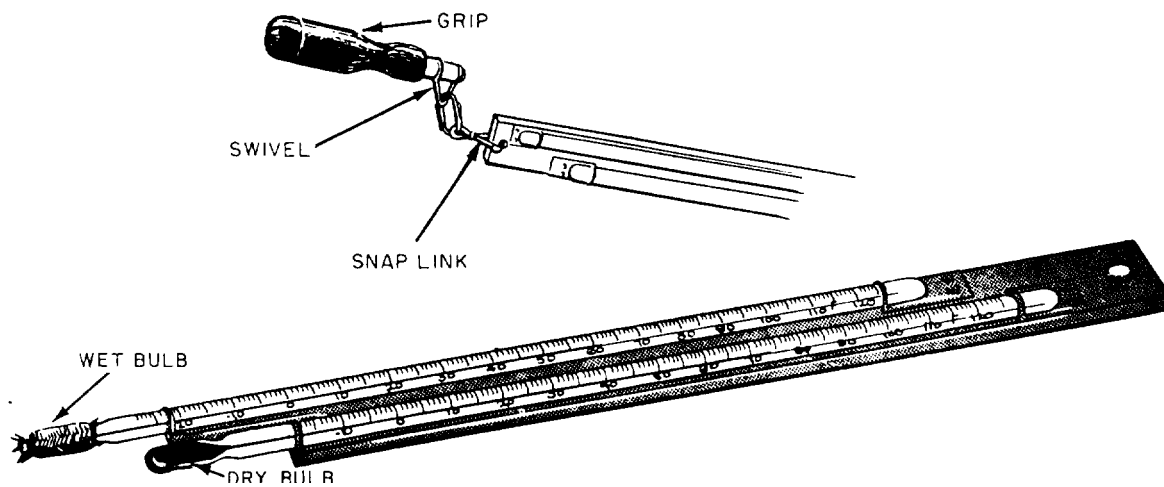
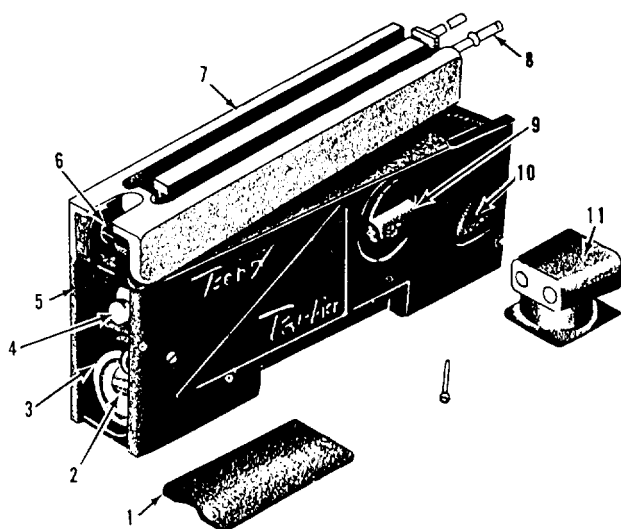

Figure 10-13.-A standard sling Psychrometer.



- |                        |                        |
|------------------------|------------------------|
| 1. Sliding door        | 7. Thermometer holder  |
| 2. Spring contact      | 8. Wet-bulb wick       |
| 3. Battery compartment | 9. Knob                |
| 4. Water bottle        | 10. Exhaust ports      |
| 5. Bottle compartment  | 11. Sliding air intake |
| 6. Hinge pin           |                        |

Figure 10-14.-Exposed view of motorized psychrometer.

When the air is saturated, all three temperatures are the same.

By using both the wet-bulb and the dry-bulb temperature readings, you can find the relative humidity and the dew-point temperature on a psychrometric chart (fig. 10-15).

**DEW-POINT TEMPERATURE.**- The wet-bulb temperature lines are angled across the chart (see fig.

10-15). The dew-point temperature lines are straight across the chart (indicated by the arrows for wet bulb and dew point). Find where the wet-bulb and dry-bulb lines cross, interpolate the relative humidity from the nearest humidity lines to the temperature-line crossing point. Then, to find the dew point, follow the straight dew-point line closest to the intersection across to the right of the chart and read the dew-point temperature. For example, find the wet-bulb temperature of 70°F. Next, trace the line angling down to the right to the dry-bulb temperature of 95°F. Finally, to find the dew-point temperature, follow the dew-point temperature lines nearest the intersection straight across to the right of the chart. The dew-point line falls about one-third of the way between the 55°F mark and the 60° mark. You can see that the dew-point temperature is about 57°F.

**RELATIVE HUMIDITY.**- To find the relative humidity (see fig. 10- 15), first find the dry-bulb temperature. Read across the bottom, find 95°F and follow straight up to the intersection of the wet- and dry-bulb readings. The relative humidity arc nearest the intersection is 30 percent. However, the intersecting line is below 30 percent and higher than 20 percent. You can see that the relative humidity is about 28 percent.

## BODY HEAT BALANCE

Ordinarily, the body remains at a fairly constant temperature of 98.6°F. It is important to maintain this body temperature. Since there is a continuous heat gain from internal body processes, there must be a continuous loss to maintain body heat balance. Excess heat must be absorbed by the surrounding air or lost by radiation. As the temperature and humidity of the

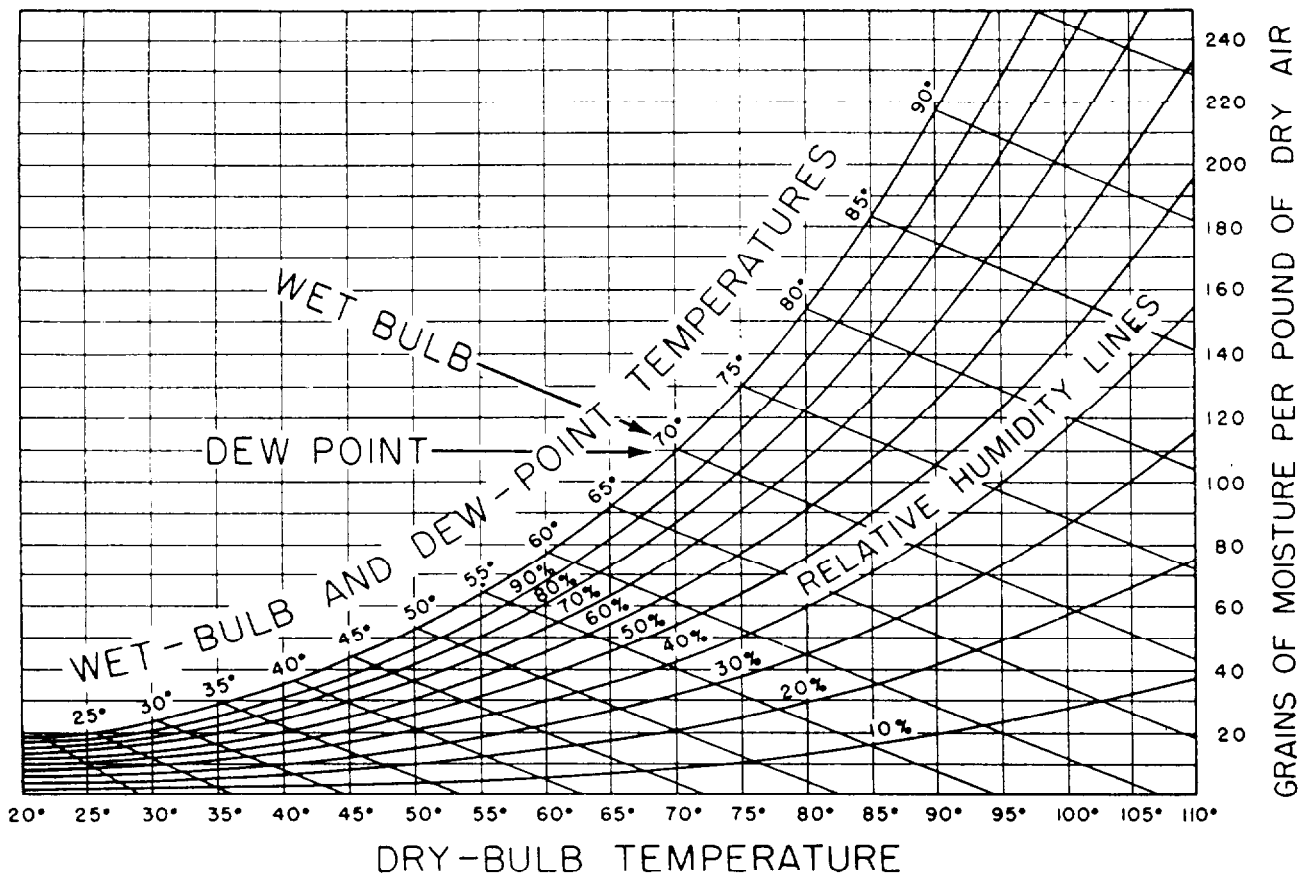

Figure 10-15. Simplified psychrometric chart.

environment vary, the body automatically regulates the amount of heat that it gives off. However, the body's ability to adjust to varying environmental conditions is limited. Furthermore, although the body may adjust to a certain (limited) range of atmospheric conditions, it does so with a distinct feeling of discomfort. The discussion that follows will help you understand how atmospheric conditions affect the body's ability to maintain a heat balance.

### Body Heat Gains

The body gains heat by radiation, by convection, by conduction, and as a by-product of physiological processes that take place within the body.

The heat gain by radiation comes from our surroundings. However, heat always travels from areas of higher temperature to areas of lower temperature. Therefore, the body receives heat from those surroundings that have a temperature higher than body surface temperature. The greatest source of heat radiation is the sun. Some sources of indoor heat radiation are heating devices, operating machinery, and hot steam piping.

The heat gain by convection comes only from currents of heated air. Such currents of air may come from a galley stove or an engine.

The heat gain by conduction comes from objects with which the body comes in contact.

Most body heat comes from within the body itself. Heat is produced continuously inside the body by the oxidation of foodstuffs and other chemical processes, friction and tension within the muscle tissues, and other causes.

### Body Heat Losses

There are two types of body heat losses—loss of sensible heat and loss of latent heat. Sensible heat is given off by radiation, convection, and conduction. Latent heat is given off in the breath and by evaporation of perspiration.

### EFFECT OF AIR MOTION

In perfectly still air, the layer of air around a body absorbs the sensible heat given off by the body and



increases in temperature. The layer of air also absorbs some of the water vapor given off by the body, thus increasing its relative humidity. This means the body is surrounded by an envelope of moist air that is at a higher temperature and relative humidity than the ambient air. Therefore, the amount of heat that the body can lose to this envelope is less than the amount it can lose to the ambient air. When the air is set in motion past the body, the envelope is continuously being removed and replaced by the ambient air. This movement increases the rate of heat loss from the body. When the increased heat loss improves the heat balance, the sensation of a breeze is felt; when the increase is excessive, the rate of heat loss makes the body feel cool and the sensation of a draft is felt.

## **SENSATION OF COMFORT**

From what you have just learned, you know that three factors are closely interrelated in their effects upon the comfort and health of personnel aboard ship. These factors are temperature, humidity, and air motion. In fact, a given combination of temperature, humidity, and air motion produces the same feeling of warmth or coolness as a higher or lower temperature along with a compensating humidity and air motion. The term given to the net effect of these three factors is known as the **EFFECTIVE TEMPERATURE**. Effective temperature cannot be measured by an instrument, but can be found on a special psychometric chart when the dry-bulb temperatures and air velocity are known.

The combinations of temperature, relative humidity, and air motion of a particularly effective temperature may produce the same feeling of warmth or coolness. However, they are **NOT** all equally comfortable. Relative humidity below 15 percent produces a parched condition of the mucous membranes of the mouth, nose, and lungs, and increases susceptibility to disease germs. Relative humidity above 70 percent causes an accumulation of moisture in clothing. For best health conditions, you need a relative humidity ranging from 40 percent to 50 percent for cold weather and from 50 percent to 60 percent for warm weather. An overall range from 30 percent to 70 percent is acceptable.

## **VENTILATION EQUIPMENT**

Proper circulation is the basis for all ventilating and air-conditioning systems and related processes. Therefore, we must first consider methods used aboard ship to circulate air. In the following sections, you will

find information on shipboard equipment used to supply, circulate, and distribute fresh air and to remove used, polluted, and overheated air.

In Navy ships, the fans used with supply and exhaust systems are divided into two general classes-axial flow and centrifugal.

Most fans induct systems are of the axial-flow type because they generally require less space for installation.

Centrifugal fans are generally preferred for exhaust systems that handle explosive or hot gases. Because the motors of these fans are outside the air stream, they cannot ignite the explosive gases. The drive motors for centrifugal fans are less subject to overheating to a lesser degree than are motors of vane-axial fans.

### **VANE-AXIAL FANS**

Vane-axial fans (fig. 10-16) are high-pressure fans, generally installed in duct systems. They have vanes at the discharge end to straighten out rotational air motion caused by the impeller. The motors for these fans are cooled by the flow of air in the duct from the fan blades across the motor. The motor will overheat if it is allowed to operate while the supply air to the fan is shut off.

### **TUBE-AXIAL FANS**

Tube-axial fans are low-pressure fans, usually installed without duct work. However, they do have sufficient pressure for a short length of duct.

### **CENTRIFUGAL FANS**

Centrifugal fans (fig. 10-17, view A) are used primarily to exhaust explosive or hot gases. However, they may be used in lieu of axial-flow fans if they work better with the arrangement or if their pressure-volume characteristics suit the installation better than an axial-flow fan. Centrifugal fans are also used in some fan-coil assemblies, which are discussed later in this chapter.

### **PORTABLE FANS**

Portable axial fans (fig. 10-17, view B) with flexible air hoses are used aboard ship for ventilating holds and cofferdams. They are also used in unventilated spaces to clear out stale air or gases before personnel enter and for emergency cooling of machinery.

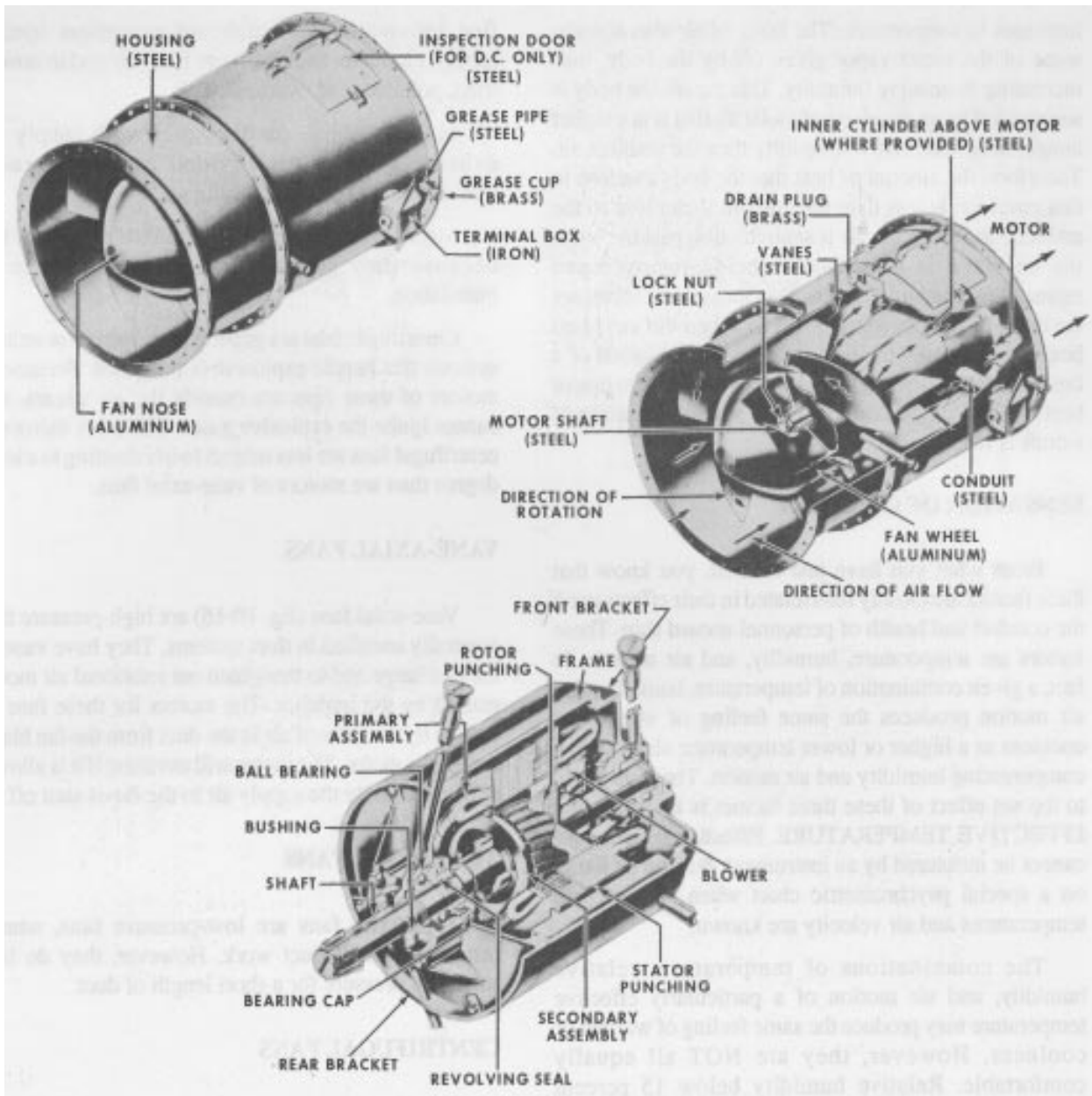

47.106

**Figure 10-16.-Vane-axial fan: A. Exterior view. B. Cutaway view. C. Cutaway view of the fan motor.**

Most portable fans are of the axial-flow type, driven by electric, explosionproof motors. On ships carrying gasoline, a few air turbine-driven centrifugal fans are normally provided. You can place greater confidence in the explosionproof characteristics of these fans.

### CAUTION

Never use a dc-driven fan to exhaust air that contains explosive vapor.

### EXHAUSTS

Many local exhausts are used to remove heat and odors. Machinery spaces, laundries, and galleys are some of the shipboard spaces where local exhausts are used.

Most exhausts used on Navy ships are mechanical (contain an exhaust fan), although natural exhausts are sometimes used in ship's structures and on small craft.

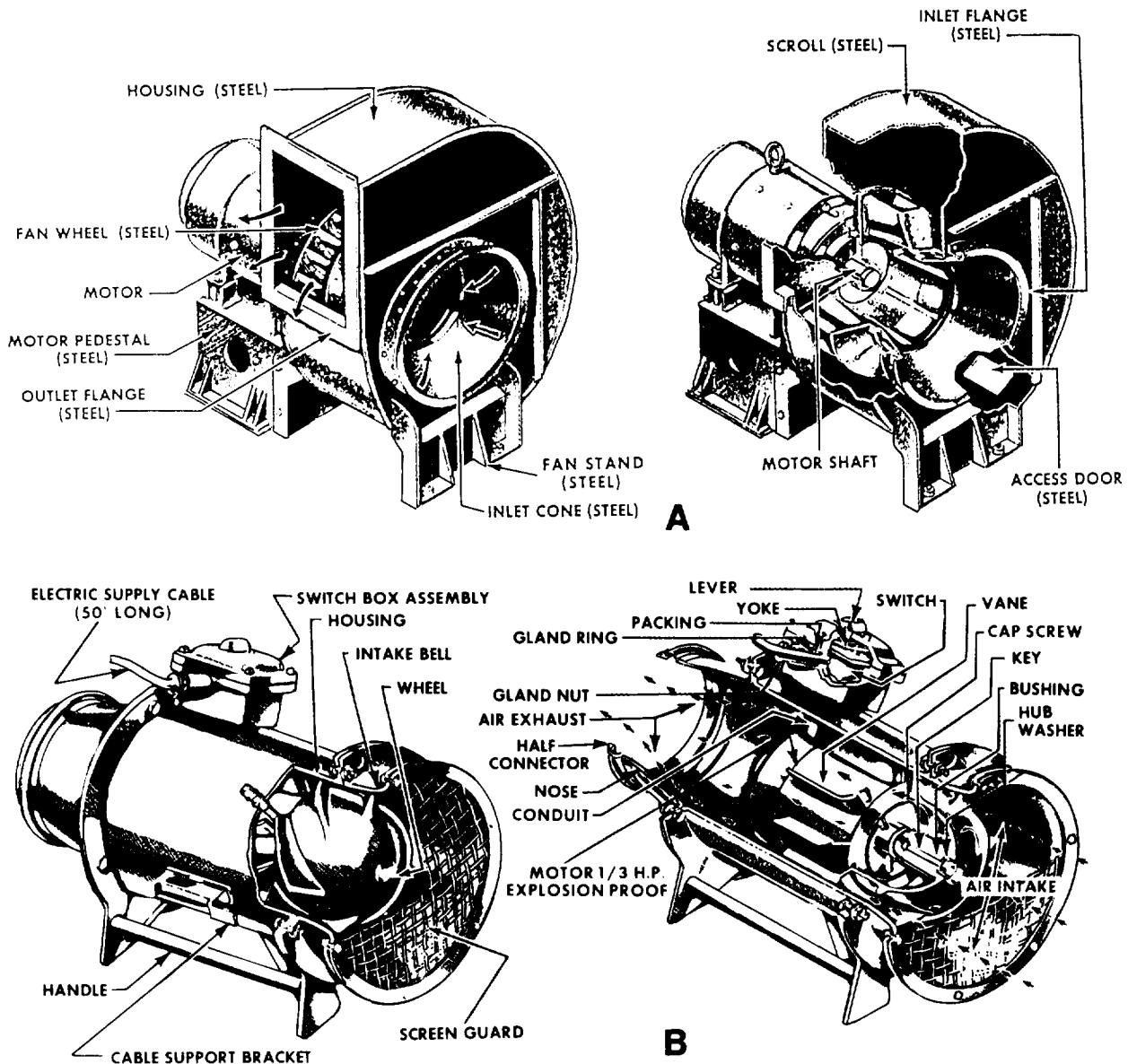

Figure 10-17.-Miscellaneous ventilation fans: A. Centrifugal fan. B. Portable axial fan.

47.107

## MECHANICAL COOLING EQUIPMENT

Almost all working and living spaces on newer ships are air conditioned. The equipment used on these ships was carefully tested to see which types would best dehumidify and cool ship compartments. Two basic types of equipment have been found most effective and are now in general use. They are chilled water circulating systems and self-contained air conditioners.

### CHILLED WATER CIRCULATING SYSTEMS

TWO basic types of chilled water air-conditioning systems are now in use. They are a vapor compression

unit and a lithium bromide absorption unit. In the vapor compression unit, the primary refrigerant cools the secondary refrigerant (chilled water) that is used to cool the spaces. This type uses the vapor compression cycle and R-11 or R-114 as the primary refrigerant. The type of primary refrigerant depends on the size and type of compressor. The lithium bromide unit operates on the absorption cycle and uses water as the primary refrigerant. Lithium bromide is used as an absorbent.

Vapor compression plants are used in most ships. However, lithium bromide plants are used in submarines because they require no compression, which means a quieter operation.

## Vapor Compression Units

The vapor compression chilled water circulating system differs from a refrigerant circulating (direct expansion) air-conditioning system. In vapor compression chilled water circulating systems, the air is conditioned by using a secondary refrigerant (chilled water) that is circulated to the various cooling coils. Heat from the air-conditioned space is absorbed by the circulating chilled water. Heat is then removed from the water by the primary refrigerant system in the water chiller. In large ton vapor compression systems, the compressor is a centrifugal type that uses R-11 or R-114 as the primary refrigerant.

The operating cycle of the centrifugal refrigeration plant (fig. 10-18) is basically the same as other refrigeration plants except for the method of

compression. The refrigerant gas is pressurized in the centrifugal turbocompressor. This then is discharged into the condenser where it is condensed by circulating seawater flowing through the condenser tubes. The condensed liquid refrigerant drains to the bottom of the condenser into a float chamber. When the refrigerant level is high enough, a float-operated valve opens. (NOTE: In some R-11 units, an orifice is installed instead of a float valve.) This allows the liquid high-pressure refrigerant to spray out into the water chiller (evaporator). Water to be chilled flows through the tubes of the water chiller. As the refrigerant from the condenser sprays out over the tubes, the water within the tubes is chilled or cooled due to the vaporization of the liquid refrigerant. Then, the vaporized refrigerant reenters the suction side of the compressor to start the cycle again.

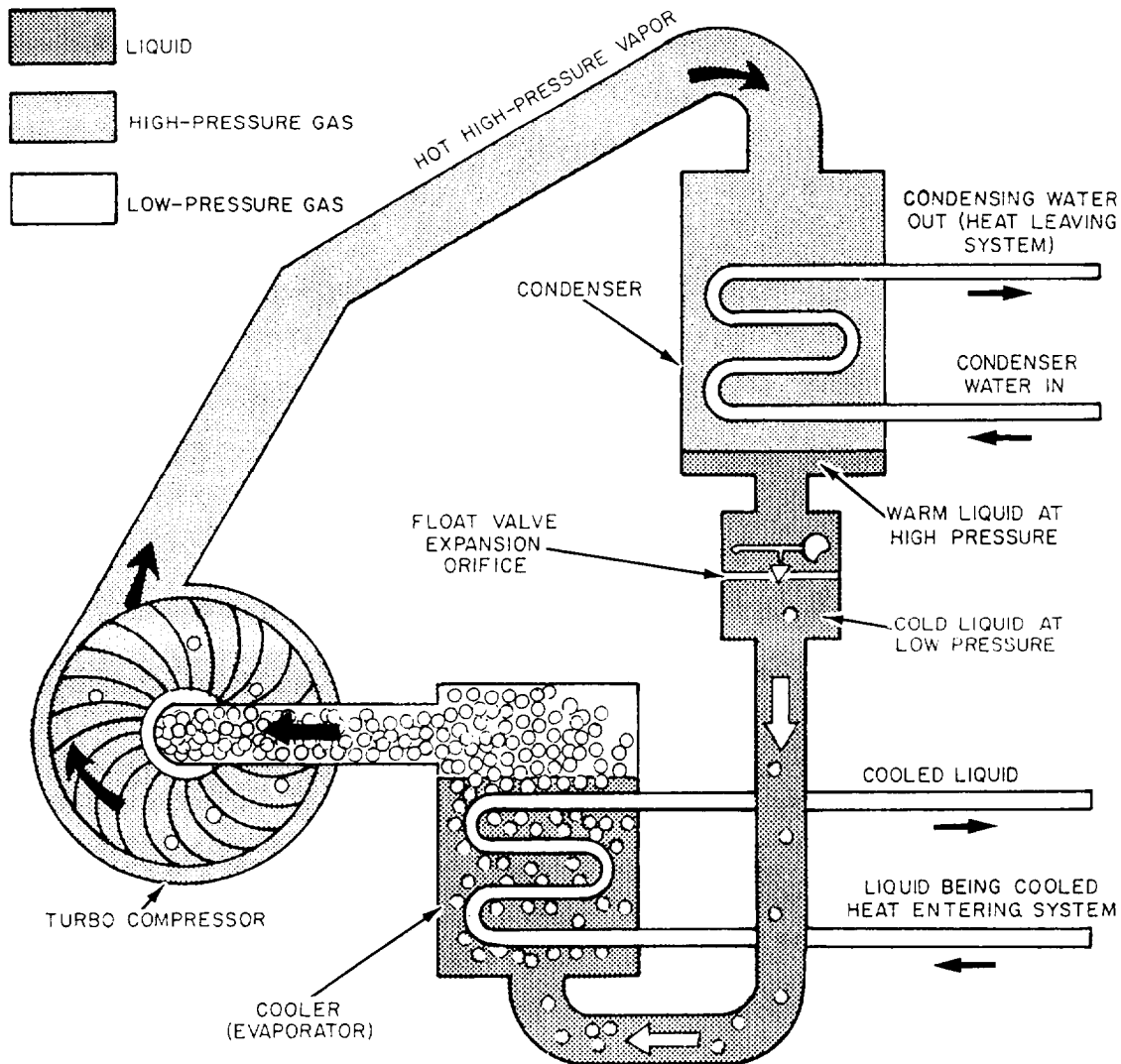

Figure 10-18-Vapor compressor (centrifugal) unit.

The load on the air-conditioning plant is determined by the desired chilled water temperature. The compressor load is changed by either an increased or decreased demand of the chilled water temperature. Upon demand, the load is changed by the use of adjustable prerotation vanes. The vanes are located on the suction side of the compressor. The vanes act as dampers to increase or decrease the flow of refrigerant vapor into the suction of the compressor. This throttling action at the compressor suction allows an increase or decrease of the capacity of the compressor without changing the compressor speed.

Figure 10-19 shows a centrifugal compressor with the inlet piping removed. Note that the prerotation vanes are in the fully open position. The vane position is normally controlled automatically through an electropneumatic control system. The control system senses and maintains the chilled water outlet temperature of the chiller at a preset value by varying the position of the vanes.

In some plants, the electric motor used In some plants, the electric motoerrive the compressor is hermetically sealed and is cooled by a flow of refrigerant through it. The compressor is lubricated by a force-feed lubrication system. This system normally consists of an auxiliary oil pump, an attached oil pump (integral with compressor), an oil cooler, and a set of oil filters. The auxiliary oil pump is used for starting and securing the plant.

Several automatic controls are built into the centrifugal compressor control system. These devices increase the self-operating ability of the plant by automatically shutting down the compressor if a hazardous condition develops. Some of these conditions are high condenser pressure, low compressor lube oil pressure, seawater loss to the condenser, loss of chilled water, low refrigerant temperature, low chilled water temperature, and high discharge temperature.

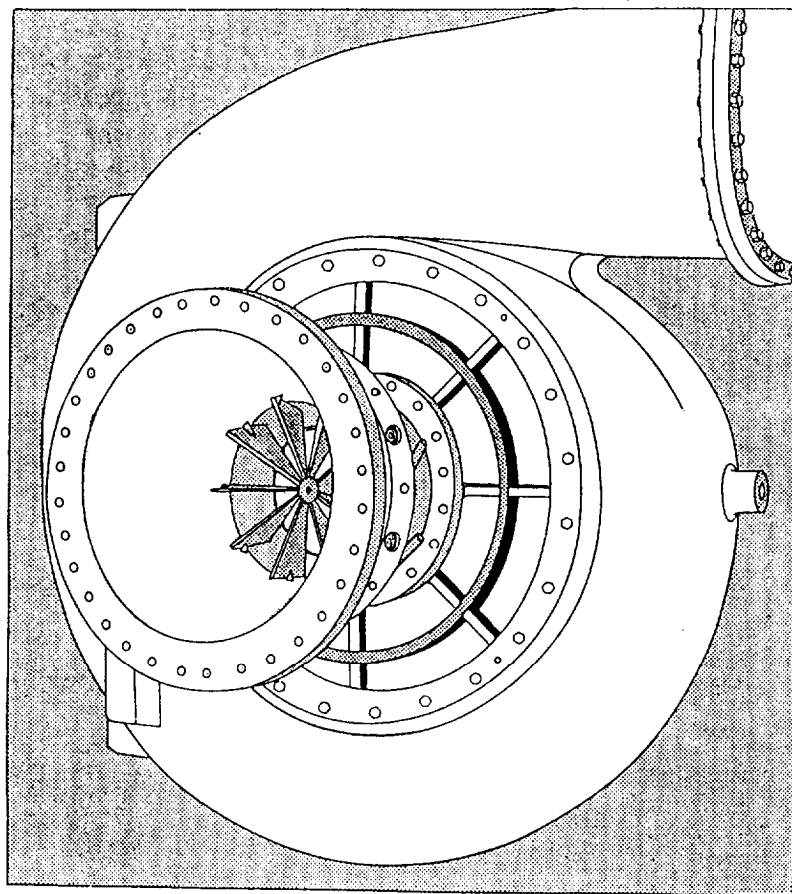

Figure 10-19. Suction end of a centrifugal compressor showing prerotation vanes.

An oil heater keeps the oil warm in the oil sump of the compressor during plant shutdown. If the oil is not kept heated, it absorbs large amounts of refrigerant. This results in excessive oil foaming when the unit is started. The heaters in most plants are connected so that they are automatically turned on when the compressor is off, and off when the compressor is on..

Figure 10-20 shows a centrifugal compressor air-conditioning unit. This particular plant has a 150-ton capacity and uses R-114 as the refrigerant. The gauges and controls for the plant are on the other side of the unit.

### Lithium Bromide Absorption Unit

Water is used as a refrigerant in the lithium bromide absorption cycle. The absorption system differs from the compression-type refrigeration machines. The absorption cycle uses heat energy instead of mechanical energy to cause the change in conditions necessary for a complete refrigeration cycle. In other words, the compressor is replaced by steam heat.

The following are the two principles that form the basis for the lithium bromide absorption refrigeration cycle:

1. Lithium bromide has the ability to absorb large quantities of water vapor.

2. When under a high vacuum, water boils (vaporizes) at a low temperature and, in doing so, absorbs heat.

To understand the lithium bromide absorption cycle, follow along on figure 10-21 during as you read the following explanation. Notice that the EVAPORATOR and ABSORBER sections are in a common shell. The sections are separated by the refrigerant tray and baffles. This shell is under a high vacuum of about 29.8 in.Hg. Water boils at 35°F (1.7°C) at this pressure. (Note that this is only 3°F above the freezing point of water.) The refrigerant pump circulates the refrigerant (water) through the evaporator. The water is sprayed out over 88the chilled water tubes through a spray header. This causes the water to vaporize (or flash) more readily. As the water vaporizes around the chilled water tubes, it removes heat from the circulating chilled water. The water vapor is floating about in the evaporator/absorber shell. Now, the absorber comes into play.

Lithium bromide solution is sprayed out from a spray header in the absorber. The absorber pump provides the driving head for the spray. As the lithium bromide solution is sprayed out, it absorbs the water vapor, which is in the shell from the evaporation process. As the lithium bromide absorbs more and more water vapor, its ability to absorb decreases. This is

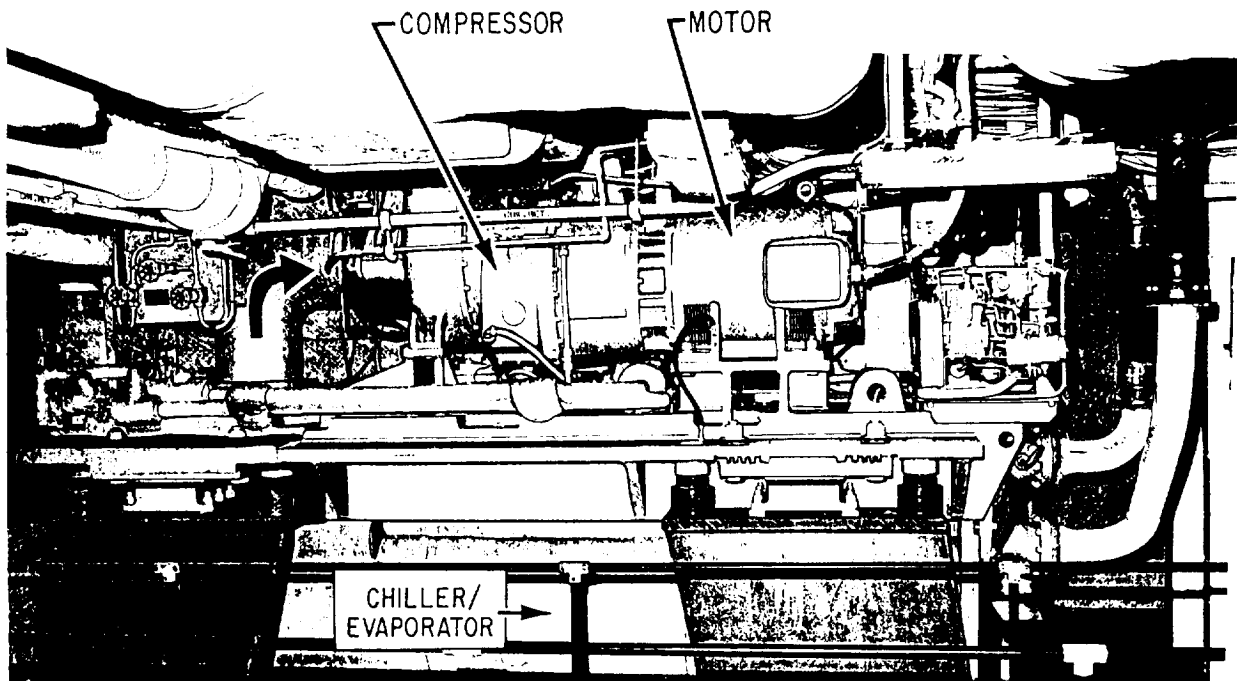

Figure 10-20.-R-114 centrifugal air-conditioning plant.

47.217

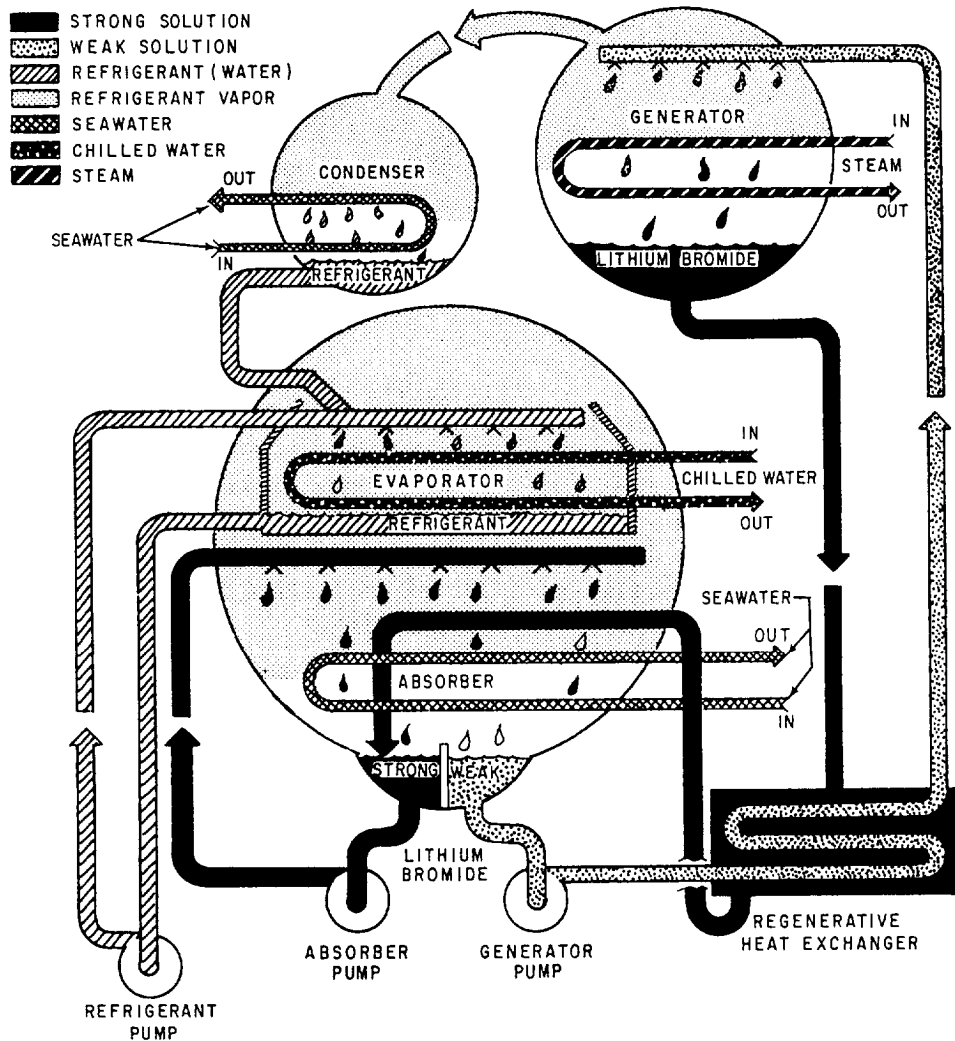

Figure 10-21.-Basic absorption cycle.

known as a WEAK solution. Here, in the generator section of the plant, the weak solution is rejuvenated for reuse as a STRONG solution. The generator pump pumps the weak solution from the weak solution section of the absorber up to the generator.

In the generator, the weak lithium bromide solution is sprayed out over steam tubes that heat the solution and drive the water vapor out of the solution. The strong solution thus produced flows back into the absorber for reuse. The water vapor driven out of the solution flows from the generator into the condenser where it is condensed by circulating seawater for reuse as a refrigerant. The condensed vapor flows into the evaporator and down to the refrigerant tray.

A regenerative heat exchanger is provided in the system for the lithium bromide solution. The weak solution must be heated to drive out the water vapor; the strong solution must be cooled to absorb water vapor.

The regenerative heat exchanger aids in this process by cooling the strong solution and preheating the weak solution in the cycle.

Seawater (condensing) flow is provided through the absorber section. It cools the strong solution returning from the generator and removes the heat produced as the lithium bromide solution absorbs the water vapor. The outlet seawater from the absorber is the inlet water for the condenser.

The absorber pump and the generator pump are driven by a common electric motor. Therefore, the two pumps are referred to cumulatively as the absorber/generator pump.

A purge system (not shown) consists of a pump, an eductor, and a purge tank. The system is provided with the lithium bromide absorption system to keep air and noncondensables out of the evaporator/absorber shell.

The maintenance of the high vacuum within the shell is important to the proper operation of the plant.

### Fan-Coil Assemblies

Fan-coil assemblies (fig. 10-22) use chilled water to air-condition spaces. These assemblies are known as spot coolers. The chilled water is piped through the cooling coils of the units, and a fan forces air over the coils. Note the chilled water connections, the vent cock at the top, and the condensate collection tray at the bottom of the unit.

The condensate collection tray collects the moisture condensed out of the air. The condensate is generally piped to the bilge or a waste water drain system. It is important that the drain for the collection tray be kept clear. If the condensate cannot drain out of the tray, it collects and evaporates, leaving impurities that can rapidly cause the tray to corrode.

### SELF-CONTAINED AIR CONDITIONERS

Ships without central air conditioning may use self-contained air-conditioning units. Naval Sea Systems Command (NAVSEASYS COM) approval is required. A self-contained air-conditioning unit is simply the type of air conditioner you see installed in the windows of many homes. All that is required for installation is to mount the proper brackets for the unit case and provide electrical power.

These units use nonaccessible hermetically sealed compressors (motor and compressor are contained in a welded steel shell). For this reason, shipboard maintenance of the motor-compressor unit is impractical. The thermal expansion valve used in these units is preset and nonadjustable. However, a thermostat and fan speed control are normally provided for comfort adjustment.

### AIR COMPRESSORS

The air compressor is the heart of any compressed air system. It takes in atmospheric air, compresses it to the desired pressure, and moves it into supply lines or into storage tanks for later use. Air compressors come in different designs and configurations and have different methods of compression. Some of the most common types used on gas turbine ships are discussed in this chapter.

Before describing the various types of air compressors, you need to know about the composition of air and some of the things air may contain. This discussion should help you understand why air compressors have special features that prevent water, dirt, and oil vapor from getting into compressed air piping systems.

Air is mostly composed of nitrogen and oxygen. At atmospheric pressure (within the range of temperatures for the earth's atmosphere), air is in a gaseous form. The

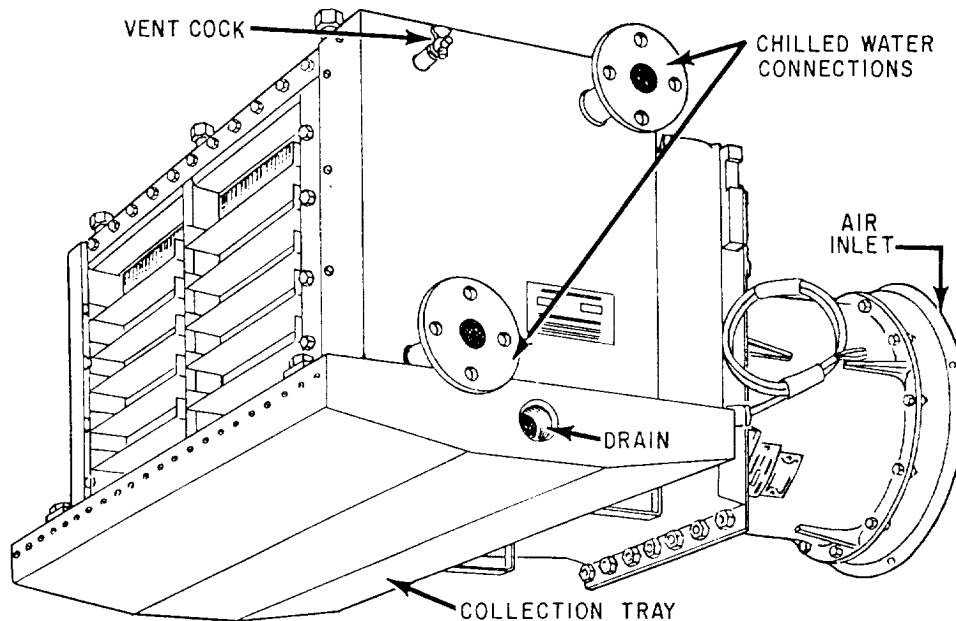

Figure 10-22.-Fan-coil assembly.



earth's atmosphere also contains varying amounts of water. Depending on weather conditions, water will appear in a variety of forms, such as rain (liquid water), snow crystals, ice (solid water), and vapor. Vapor is composed of tiny drops of water that are light enough to stay airborne. Clouds are an example of the existence of water vapor.

Since air is a gas, it expands when heated. Consequently, heating air causes a given amount of air to expand, take up more space (volume), and hold more water vapor. When a given amount of air at a given temperature and pressure is no longer able to soak up water vapor, the air is saturated, and the humidity is 100 percent.

When air cools, its density increases; however, its volume and ability to hold water decrease. When temperature and pressure conditions cause the air to cool and to reach the dew point, any water vapor in the air condenses into a liquid state (water). In other words, one method of drying air out is to cool it until it reaches the dew point.

Besides nitrogen, oxygen, and water vapor, air contains particles of dust and dirt that are so tiny and lightweight that they remain suspended in the air. You may wonder how the composition of air directly affects the work of an air compressor. Although one cubic foot of air will not hold a tremendous amount of water or dirt, you should realize that air compressors have capacities that are rated in hundreds of standard cubic feet per minute (cfm). This is a very high rate of flow. When a high flow rate of dirty, moisture-laden air is allowed to enter and pass through an air compressor, the result is rapid wear of the seals and load-bearing parts, internal corrosion (rust), and early failure of the unit. The reliability and useful life of any air compressor is extended by the installation of filters. Filters remove most of the dirt and dust from the air before it enters the equipment. On the other hand, most of the water vapor in the air at the intake passes directly through the filter material and is compressed with the air. When air is compressed, it becomes very hot. As you know, hot air is capable of holding great amounts of water. The water is removed as the compressed air is routed through the coolers. The coolers remove the heat from the airstream and cause some of the water vapor to condense into liquid (condensate). The condensate must be periodically drained from the compressor.

Although the coolers will remove some of the water from the air, simple cooling between the stages of compression (intercooling) and cooling of the airstream after it leaves the compressor (aftercooling) will not

make the air dry. When clean dry air suitable for pneumatic control and other shipboard systems are required air from the compressor is routed through air-drying units. Many air-drying units are capable of removing enough water vapor from the airstream to cause the dew point to be as low as -60°F. Some of the more common devices used to remove water vapor from the airstream, such as dehydrators, are discussed later in this chapter.

## CLASSIFICATION OF AIR COMPRESSORS

An air compressor may be classified according to pressure (low, medium, or high), type of compressing element, and whether the discharged air is oil free.

Because of our increasing need for oil-free air aboard ship, the oil-free air compressor is gradually replacing most of the standard low-pressure and high-pressure air compressors. For this reason, most of this discussion is focused on the features of oil-free air compressors.

The *Naval Ships' Technical Manual (NSTM)*, chapter 551, lists compressors in three classifications:

1. Low-pressure air compressors (LPACs), which have a discharge pressure of 150 psi or less
2. Medium-pressure compressors, which have a discharge pressure of 151 psi to 1,000 psi
3. High-pressure air compressors (HPACs), which have a discharge pressure above 1,000 psi

### Low-Pressure or Ship's Service Air Compressors

The two types of LPACs that are used on naval ships are the screw type and the reciprocating type.

**SCREW TYPE.**— The helical-screw type of compressor is a relatively new design of oil-free air compressor. This low-pressure air compressor is a single-stage, positive-displacement, axial-flow, helical-screw type of compressor. It is often referred to as a screw-type compressor. Figure 10-23 shows the general arrangement of the LPAC unit.

In the screw-type LPAC, compression is caused by the meshing of two helical rotors (a male and a female rotor, as shown in fig. 10-24) located on parallel shafts and enclosed in a casing. Air inlet and outlet ports are located on opposite sides of the casing. Atmospheric air is drawn into the compressor through the filter-silencer. The air passes through the air cylinder-operated unloader (butterfly) valve and into the

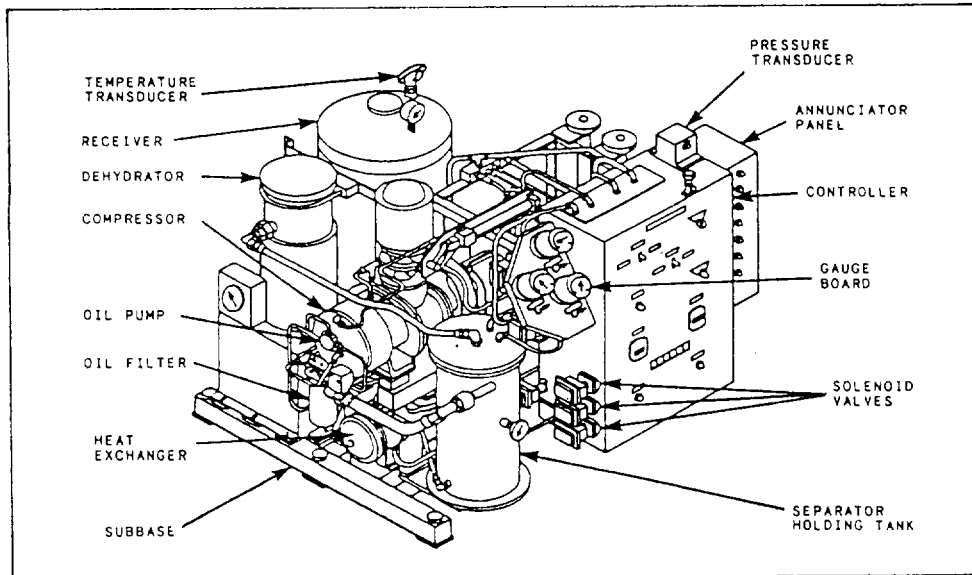

Figure 10-23. LPAC unit (screw type.)

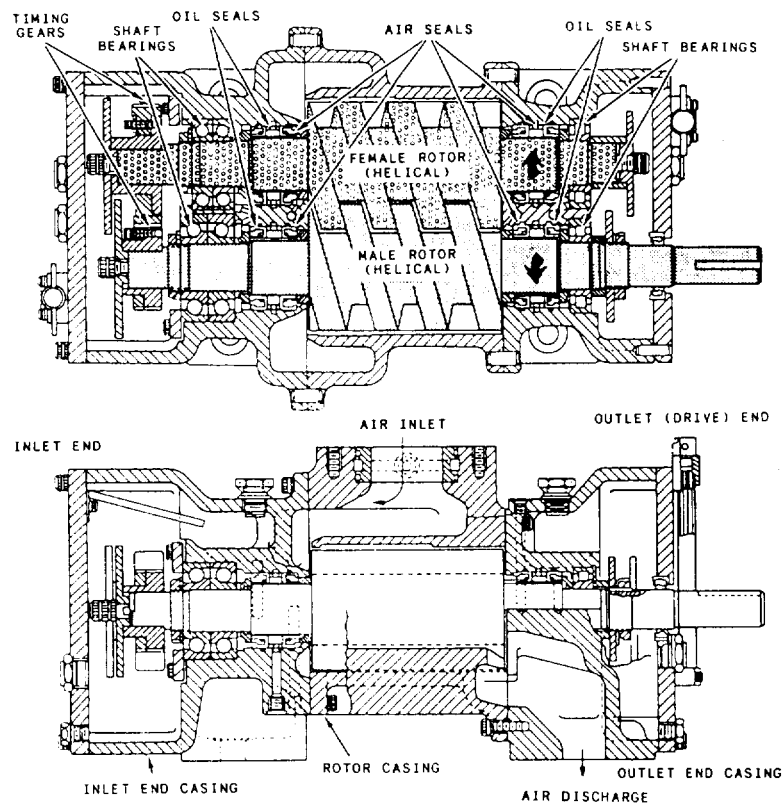

Figure 10-24. LPAC, compressor section.

inlet part of the compressor when the valve is in the open (load) position. Fresh water is injected into the airstream as it passes through the inlet port of the compressor casing. The injected fresh water serves two purposes:

1. It reduces the air discharge temperature caused by compression.

2. It seals the running clearances to minimize air leak.

Most of the injected water is entrained into the airstream as it moves through the compressor.

The compression cycle starts as the rotors unmesh at the inlet port. As rotation continues, air is drawn into

the cavity between the male rotor lobes and into the grooves of the female rotor. The air is trapped in these grooves, or pockets, and follows the rotative direction of each rotor. As soon as the inlet port is closed, the compression cycle begins as the air is directed to the opposite (discharge) end of the compressor. The rotors mesh, and the normal free volume is reduced. The reduction in volume (compression) continues with a resulting increase in pressure, until the closing pocket reaches the discharge port.

The entrained water is removed from the discharged air by a combined separator and water holding tank. The water in the tank passes through a seawater-cooled heat exchanger. The cooled water then recirculates to the compressor for re-infection.

During rotation and throughout the meshing cycle, the timing gears maintain the correct clearances between the rotors. Since no contact occurs between the rotor lobes and grooves, between the rotor lobes and casing, or between the rotor faces and end walls, no internal oil lubrication is required. This design allows the compressor to discharge oil-free air.

For gear and bearing lubrication, lube oil from a force-feed system is supplied to each end of the compressor. Mechanical seals serve to keep the oil isolated from the compression chamber.

**RECIPROCATING TYPE.**— All reciprocating air compressors are similar to each other in design and operation. The following discussion describes the basic components and principles of operation of a low-pressure reciprocating air compressor.

The LPAC is a vertical, two-stage single-acting compressor that is belt-driven by an electrical motor. Two first-stage cylinders and one second-stage cylinder are arranged in-line in individual blocks mounted to the crankcase (frame) with a distance piece (frame extension). The crankcase is mounted on a subbase that supports the motor, moisture separators, and a rack assembly. The intercooler, aftercooler, freshwater heat exchanger, and freshwater pump are mounted on the rack assembly. The subbase serves as the oil sump. Figure 10-25 shows the general arrangement of the reciprocating-type compressor.

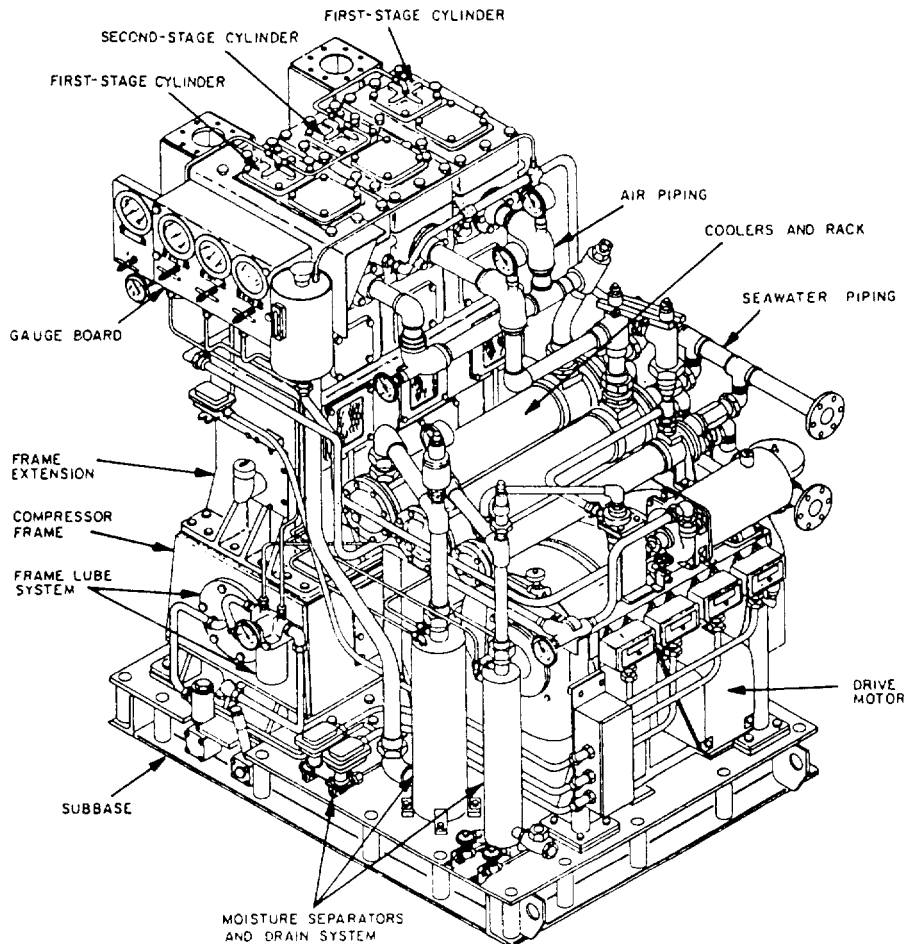

Figure 10-25.—LPAC (reciprocating type).

The compressor is of the crosshead design. Figure 10-26 shows cross-sectional views of the LPAC. The frame extension houses the crossheads and crosshead guides and is open to the atmosphere. It separates the cylinders, which are not oil lubricated, from the crankcase. Oil wiper assemblies (seals) are located in the frame extension to scrape lubricating oil off the piston rods when the compressor is in operation. Oil deflector plates are attached to the piston rods to prevent any oil that creeps through the scrapers from entering the cylinders. Oil that is scraped from the piston rods drains back to the sump. Air leak along the piston rods

is prevented by full floating packing assemblies bolted to the underside of the cylinder blocks.

During operation, ambient air is drawn into the first-stage cylinders through the inlet filter silencers and inlet valves during the downstroke. When the piston reaches the bottom of its stroke, the inlet valve closes and traps the air in the cylinder. When the piston moves upward, the trapped air is compressed and forced out of the first-stage cylinders, through the first-stage cooler and the first-stage moisture separator. When the second-stage piston starts its downstroke, the air is drawn into the second-stage cylinder. Then, it is further

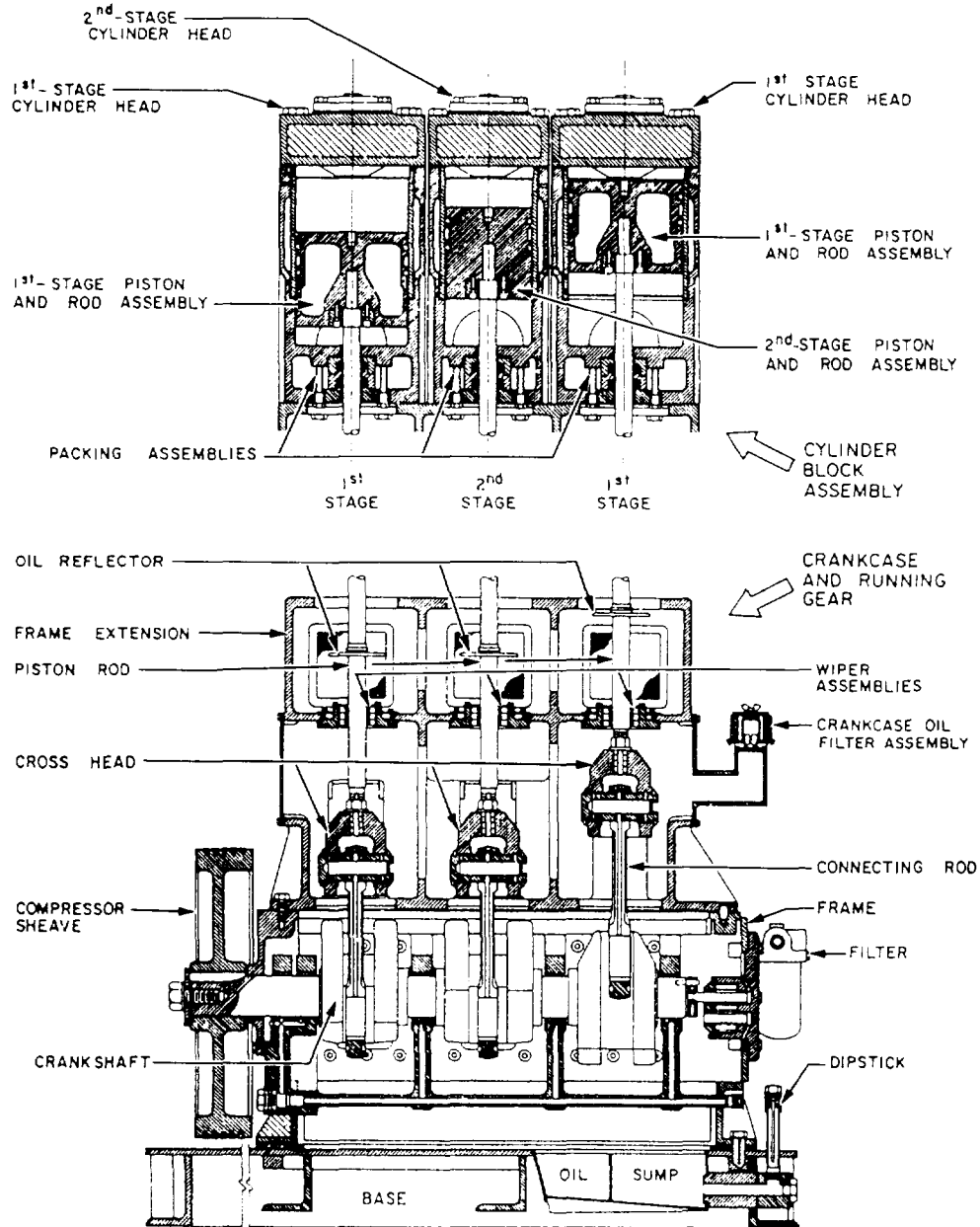

Figure 10-26.—LPAC, cross-sectional views (reciprocating type.)

compressed, followed by a cooling and moisture removal process similar to the first stage.

### High-Pressure Air Compressors

The HPAC is a vertical, five-stage, reciprocating air compressor. It is driven by being directly connected to an electrical motor. Refer to figures 10-27 and 10-28 as we describe the compressor.

The subbase supports the compressor assembly, the electric drive motor, and the coolers and rack assembly. The crankcase is bolted directly to the subbase and is made up of the frame and frame extension. The frame houses the crankshaft and oil pump. The frame extension is open to the atmosphere and isolates the conventionally lubricated frame from the oil-free cylinders. The crosshead guides are machined in the frame extension. A uniblock casting contains the first three-stage cylinders and is mounted on the frame extension (fig. 10-28). The cylinders are arranged in line. The first stage is in the center, the second stage is at the motor end, and the third stage is outboard. The fourth stage is mounted above the second stage, and the fifth stage is above the third stage. The fourth- and

fifth-stage pistons are tandem mounted to the second- and third-stage pistons, respectively.

During operation, ambient air is drawn into the first-stage cylinder through the inlet filter and inlet valves. The first stage is double acting, and air is drawn into the lower cylinder area as the piston is moving upward. At the same time, air in the upper cylinder is being compressed and forced out the upper discharge valve. As the piston moves downward, air is drawn into the upper cylinder; likewise, air in the lower cylinder is being compressed and forced out the lower discharge valve. Compressed air leaves the first-stage discharge valves and flows through the first-stage intercooler, and into the first-stage moisture separator.

The first-stage separator has a small tank mounted on the side of the compressor frame below the gauge panel and a holding tank mounted below the cooler rack. The separators for the remaining stages handle smaller volumes of air due to compression; as a result, the separators and holding chambers are smaller and are integrated into one tank. Condensate is removed from the air as it collides with the internal tank baffles and collects in the holding chamber.

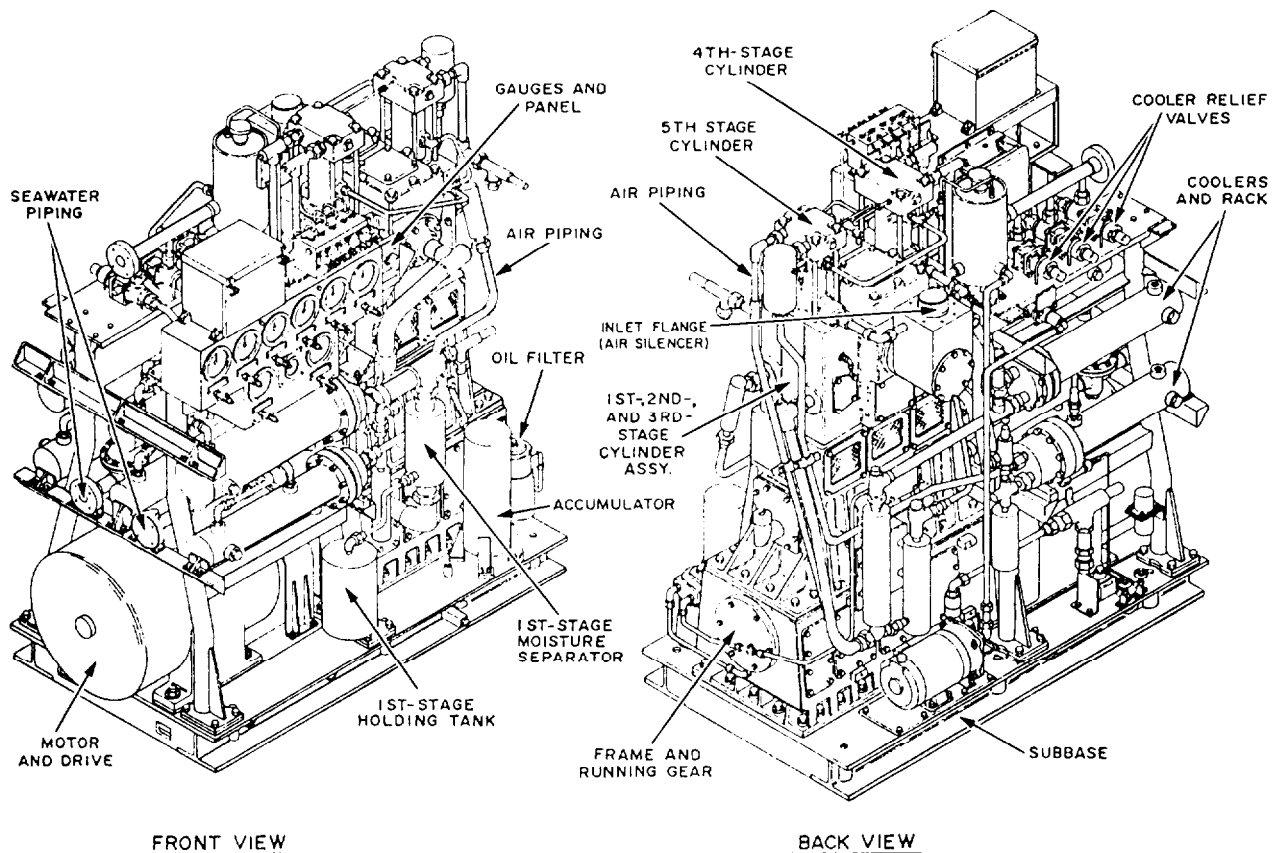

Figure 10-27.—HPAC.

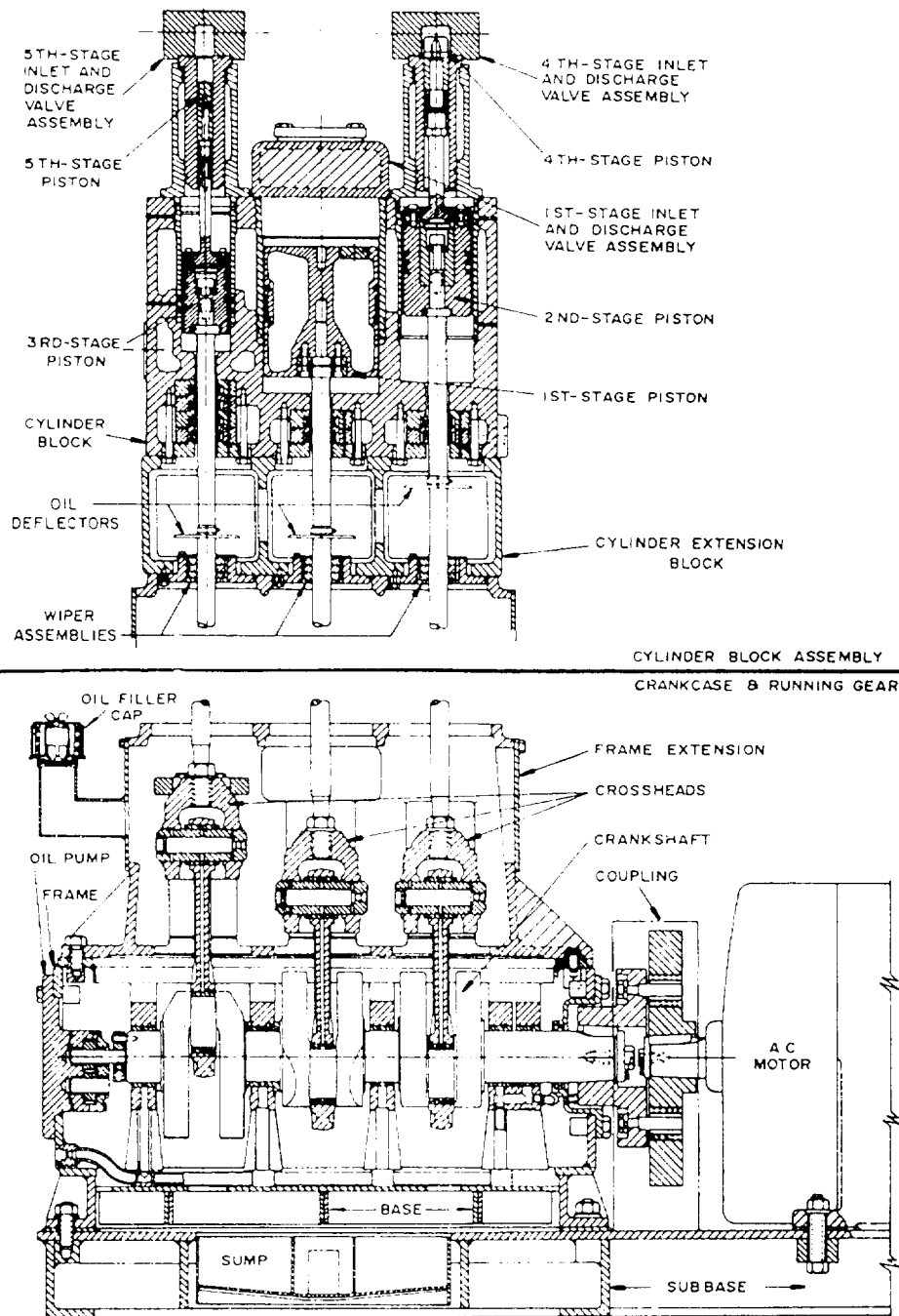

Figure 10-28.—HPAC, cross-sectional views.

Air from the first-stage separator is drawn into the single-acting, second-stage cylinder on the upward stroke of the piston. As the piston travels downward, the air is compressed and forced out the discharge valve. The second-stage discharge air passes through the second-stage intercooler into the second separator.

The third stage draws air from the second separator and compresses it in the same manner as in the second stage. Third-stage air enters a pulsation bottle before

passing through the third-interstage cooler. Pulsation bottles are used after the third and fifth compression stages to minimize the shock effect of inlet and discharge pulses as well as pressure changes due to condensate draining.

After passing through the third-interstage cooler and moisture separator, the air is drawn into the fourth-stage cylinder on the downstroke of the piston. As the piston travels upward, the air is compressed and

forced out the discharge valve. Then it passes through the fourth-stage intercooler and moisture separator.

Air is drawn into the fifth-stage cylinder on the piston downstroke and is compressed and discharged on the upstroke. The discharge air passes through the fifth-stage pulsation bottle, the aftercooler, the moisture separator, a back-pressure valve, and a check valve before entering the ships' HP piping.

## SAFETY PRECAUTIONS

Many hazards are associated with pressurized air, particularly air under high pressure. Dangerous explosions have occurred in high-pressure air systems because of DIESEL EFFECT. If a portion of an unpressurized system or component is suddenly and rapidly pressurized with high-pressure air, a large amount of heat is produced. If the heat is excessive, the air may reach the ignition temperature of the impurities present in the air and piping (oil, dust, and so forth). When the ignition temperature is reached, a violent explosion will occur as these impurities ignite. Ignition temperatures may also result from other causes. Some are rapid pressurization of a low-pressure dead-end portion of the piping system, malfunctioning of compressor aftercoolers, and leaky or dirty valves.

Air compressor accidents have also been caused by improper maintenance procedures. These accidents can happen when you disconnect parts under pressure, replace parts with units designed for lower pressures, and install stop valves or check valves in improper locations. Improper operating procedures have resulted in air compressor accidents with serious injury to personnel and damage to equipment.

You must take every possible step to minimize the hazards inherent in the process of compression and in the use of compressed air. Strictly follow all safety precautions outlined in the manufacturer's technical manuals and in the NSTM, chapter 551. Some of these hazards and precautions are as follows:

1. Explosions can be caused by dust-laden air or by oil vapor in the compressor or receiver if abnormally high temperatures exist. Leaky or dirty valves, excessive pressurization rates, or faulty cooling systems may cause these high temperatures.

2. NEVER use distillate fuel or gasoline as a degreaser to clean compressor intake filters, cylinders, or air passages. These oils vaporize easily and will form a highly explosive mixture with the air under compression.

3. Secure a compressor immediately if you observe that the temperature of the air being discharged from any stage exceeds the maximum temperature specified.

4. NEVER leave the compressor station after starting the compressor unless you are sure that the control and unloading devices are operating properly.

5. Before working on a compressor, make sure the compressor is secured. Make sure that it cannot start automatically or accidentally. Completely blow down the compressor, and then secure all valves (including the control or unloading valves) between the compressor and the receiver. Follow the appropriate tag-out procedures for the compressor control valves and the isolation valves. When the gauges are in place, leave the pressure gauge cutout valves open at all times.

6. Before disconnecting any part of an air system, be sure the part is not under pressure. Always leave the pressure gauge cutout valves open to the sections to which they are attached.

7. Avoid rapid operation of manual valves. The heat of compression caused by a sudden flow of high-pressure air into an empty line or vessel can cause an explosion if oil or other impurities are present. Slowly crack open the valves until flow is noted, and keep the valves in this position until pressure on both sides has equalized. **Keep the rate of pressure rise under 200 psi per second.**

## DEHYDRATORS

The removal of moisture from compressed air is an important feature of compressed air systems. As you have learned, some moisture is removed by the intercoolers and aftercoolers. Air flasks and receivers are provided with low-point drains so any collected moisture may drain periodically. However, many shipboard uses for compressed air require air with an even smaller moisture content than is obtained through these methods. Water vapor in air lines can create other potentially hazardous problems. Water vapor can cause control valves and controls to freeze. These conditions can occur when air at very high pressure is throttled to a low-pressure area at a high-flow rate. The venturi effect of the throttled air produces very low temperatures that cause any moisture in the air to freeze into ice. Under these conditions, a valve (especially an automatic valve) may become very difficult or impossible to operate. Also, moisture in any air system can cause serious water hammering (a banging sound) within the system. For these reasons, air dehydrators or

dryers are used to remove most of the water vapor from compressed air.

The Navy uses two basic types of air dehydrators and a combination of the two. These air dehydrators are classified as follows:

1. Type I-refrigeration
2. Type II-heater, desiccant
3. Type III-refrigeration, desiccant

Each of these types meets the specified requirements for the quality of the compressed air used in pneumatic control systems or for clean, dry air used for shipboard electronic systems. Usually, specific requirements involve operating pressure, flow rate, dew point, and purity (percent of aerosols and size of particles). We will briefly discuss each of the types of air dehydrators.

## REFRIGERATION AIR DEHYDRATOR (TYPE I)

Refrigeration is one method of removing moisture from compressed air. The dehydrator shown in figure 10-29 is a REFRIGERATION DEHYDRATOR or REFRIGERATED AIR DRYER. This unit removes water vapor entrained in the stream of compressed air by condensing the water into a liquid that is heavier than air. Air flowing from the separator/holding tank first passes through the air-to-air heat exchanger, where some of the heat of compression is removed from the airstream. The air then moves through the evaporator section of the dehydrator, where the air is chilled by circulating refrigerant. In this unit, the airstream is cooled to a temperature that is below the dew point. This will cause the water vapor in the air to condense so the condensate drain system can remove it. After leaving the evaporator section, the dehydrated air moves upward through the cold air side of the air-to-air heat exchanger.

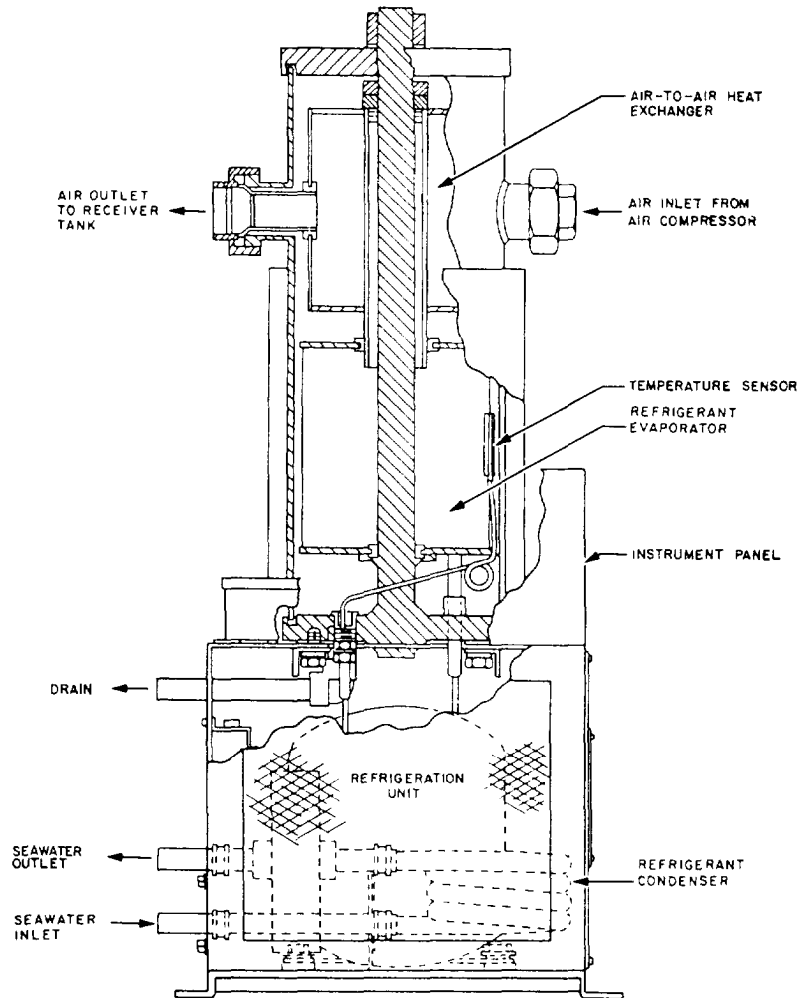

Figure 10-29.—Dehydrator (type I).



In the air-to-air heat exchanger, the dehydrated air is raised in temperature by the warm air entering the dehydrator. Heating the air serves to reduce thermal shock as the air enters the system. The exiting dry air flows into the receiver for availability to the ship's air system.

### DESICCANT AIR DEHYDRATOR (TYPE II)

The desiccant is a drying unit. More practically, desiccant is a substance with a high capacity to remove (adsorb) water or moisture. It also has a high capacity to give off that moisture so the desiccant can be reused. DESICCANT-TYPE DEHYDRATORS (fig. 10-30) are basically composed of cylindrical flasks filled with desiccant.

Compressed air system dehydrators use a pair of desiccant towers. One tower is in service dehydrating

the compressed air, while the other is being reactivated. A desiccant tower is normally reactivated when dry, heated air is routed through the tower in the direction opposite to that of the normal dehydration airflow. The hot air evaporates the collected moisture and carries it out of the tower to the atmosphere. The air for the purge cycle is heated by electrical heaters. When the reactivating tower completes the reactivation cycle, it is placed in service to dehydrate air, and the other tower is reactivated.

### REFRIGERATION AND DESICCANT AIR DEHYDRATOR (TYPE III)

Some installations may use a combination of refrigeration and desiccant for moisture removal. Hot, wet air from the compressor first enters a refrigeration section, where low temperature removes heat from the airstream and condenses water vapor from the air. Then,

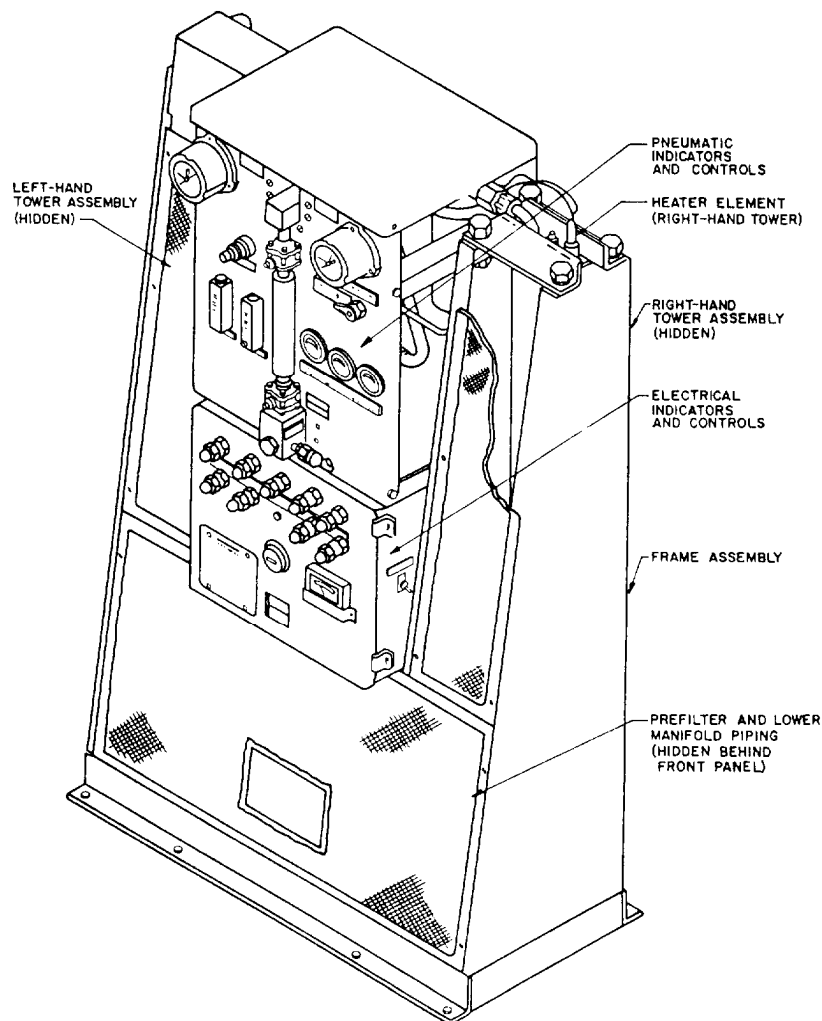

Figure 10-30.—Dehydrator (type II).

the cold, partially-dried air flows into a desiccant section, where the desiccant absorbs additional moisture from the air.

## DISTILLING PLANTS

Distilling plants are used to supply fresh water and boiler feedwater. Distillers use either steam, hot water, or electrical energy to boil seawater.

The majority of Navy ships have steam-heated distilling plants. There are three types of steam-heated distilling plants—submerged tube, flash, and vapor compression. Of these types, the submerged-tube heat recovery and flash are the most widely used.

Heat recovery units are used in vessels with engine propulsion or auxiliary engines. Two variations of the heat recovery types are used; both use the heat from engine cooling systems for evaporation of seawater.

In one model of a heat recovery plant, the heat of the diesel engine jacket water is transferred to the seawater in a heat exchanger. The heated seawater is then flashed to freshwater vapor as in the flash-type distilling unit. In the second variation, the hot diesel engine jacket water is circulated through a tube bundle that is submerged in seawater. The seawater is boiled in

a chamber that is under vacuum as in the submerged tube distilling unit.

Refer to figure 10-31, which shows a simplified flow diagram for a 12,000 gpd (gallons per day), Model S500ST, submerged-tube recovery unit. In this recovery unit, jacket water from the ship's main propulsion diesels is fed to a tube bundle. The tube is submerged in the seawater that will be evaporated. The jacket water imparts its heat to the seawater surrounding the tubes, which induces seawater evaporation. The vapor created by the evaporating seawater is drawn through vapor separators to the distillate condensing tube bundle. The temperature of evaporation is maintained below the normal 212°F boiling point by a feedwater-operated air eductor. The eductor mechanically evacuates air and gases entrained in the vapor formed in the evaporating process and creates an internal shell pressure as low as 2 1/2 psia.

The flash-type distilling plant (fig. 10-32) has preheater that heat seawater to a high temperature. Then, the seawater is admitted to a vacuum chamber where some of it flashes to vapor. The remaining seawater is directed to another vacuum chamber maintained at an even lower vacuum. Here, more seawater flashes to vapor. At this point, the remaining

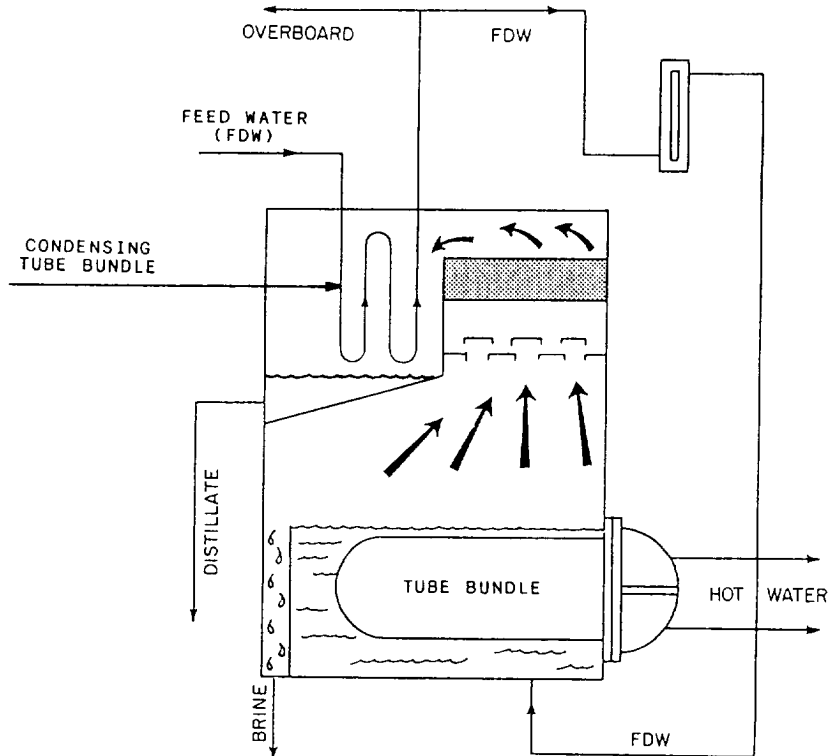

Figure 10-31.—Simplified flow diagram—heat recovery unit.

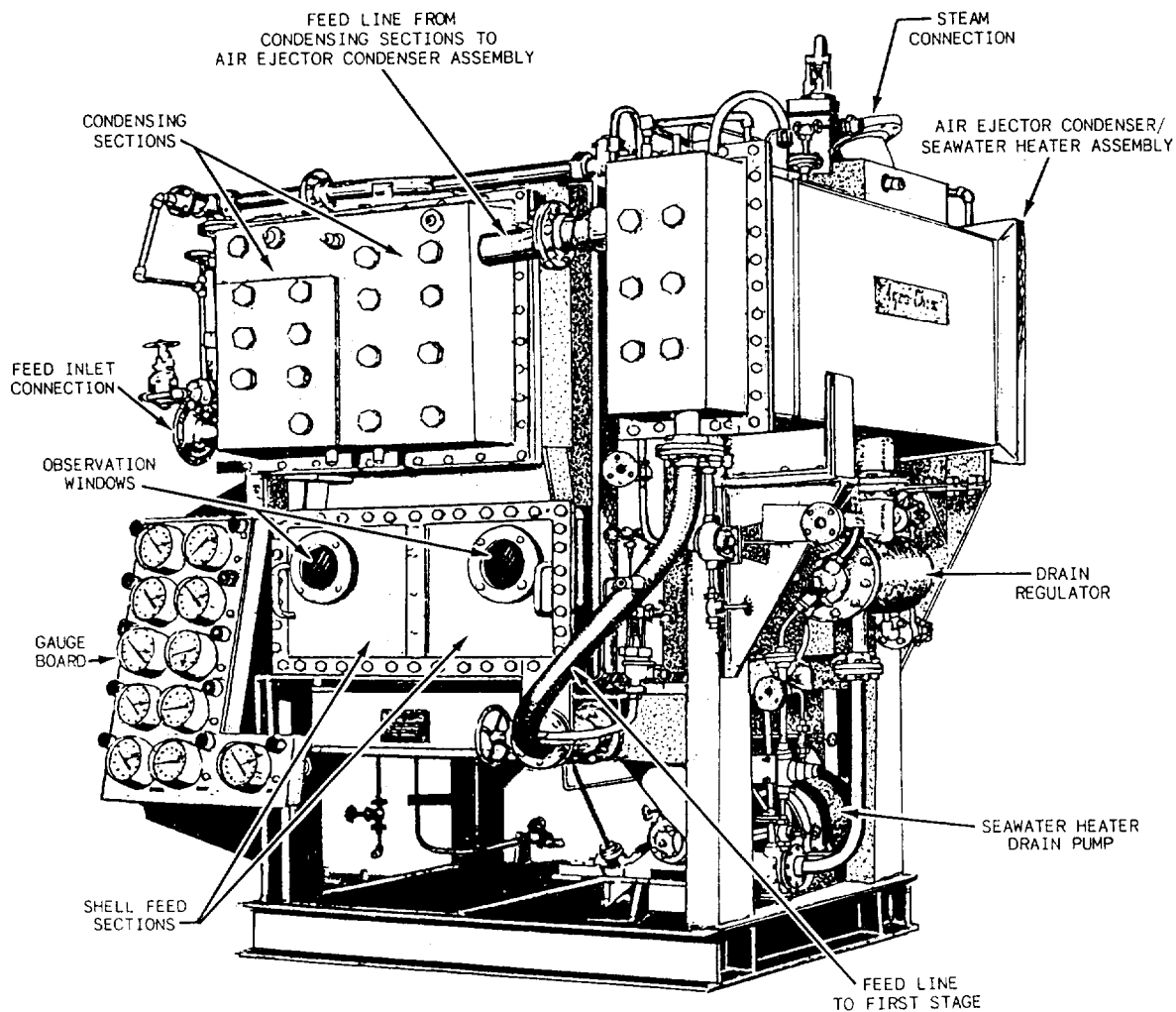

Figure 10-32.—Two-stage flash-type evaporator.

seawater is pumped overboard. Some flash-type distilling plants have as many as five flash chambers through which the seawater passes before being pumped overboard. The vapor is condensed and routed to the ship's freshwater tanks.

Distilling plants range in capacity from 2,000 to 100,000 gpd. The size depends on shipboard needs and space available. Some ships have only one distilling unit, while others have two or more.

## PURIFIERS

When you operate and maintain a purifier, you should refer to the detailed instructions that come with each purifier. These manufacturers' technical manuals contain information on the construction, operation, and maintenance of the specific purifier. You need to follow these instructions carefully. This section of the TRAMAN contains a discussion and general information on the methods of purification and the

principles of operation of centrifugal purifiers. Centrifugal purifiers are used to purify both lube oil and fuel. However, we will discuss lube oil only since the principles are the same for both.

A purifier may remove both water and sediment, or it may remove sediment only. When water is involved in the purification process, the purifier is usually called a SEPARATOR. When the principal contaminant is dirt or sediment, the purifier is used as a CLARIFIER. Purifiers are generally used as separators for the purification of fuel. When used for purification of a lube oil, a purifier may be used as either a separator or a clarifier. Whether a purifier is used as a separator or a clarifier depends on the water content of the oil that is being purified.

The following general information will help you understand the purification process, the purposes and principles of purifier operation, and the basic types of centrifugal purifiers used by the Navy.

## PURIFIER OPERATION

Centrifugal force is the fundamental operating principle used in the purification of fluid. Centrifugal force is that force exerted on a body or substance by rotation. Centrifugal force impels the body or substance out ward from the axis of rotation.

Essentially, a centrifugal purifier is a container rotated at high speed. As it rotates, contaminated lube oil is forced through, and rotates with, the container. Only materials that are in the lube oil are separated by centrifugal force. For example, water is separated from lube oil because water and lube oil are immiscible, which means they are incapable of being mixed. Also, there must be a difference in the specific gravities of the materials before they can be separated by centrifugal force. You cannot use a centrifugal purifier to separate JP-5 or naval distillate from lube oil because it is capable

of being mixed; likewise, you cannot remove salt from seawater by centrifugal force.

When a mixture of lube oil, water, and sediment stands undisturbed, gravity tends to form an upper layer of lube oil, an intermediate layer of water, and a lower layer of sediment. The layers form because of the specific gravities of the materials in the mixture. If the lube oil, water, and sediment are placed in a container that is revolving rapidly around a vertical axis, the effect of gravity is negligible in comparison with that of the centrifugal force. Since centrifugal force acts at right angles to the axis of rotation of the container, the sediment with its greater specific gravity assumes the outermost position, forming a layer on the inner surface of the container. Water, being heavier than lube oil, forms an intermediate layer between the layer of sediment and the lube oil, which forms the innermost layer. The separated water is discharged as waste, and

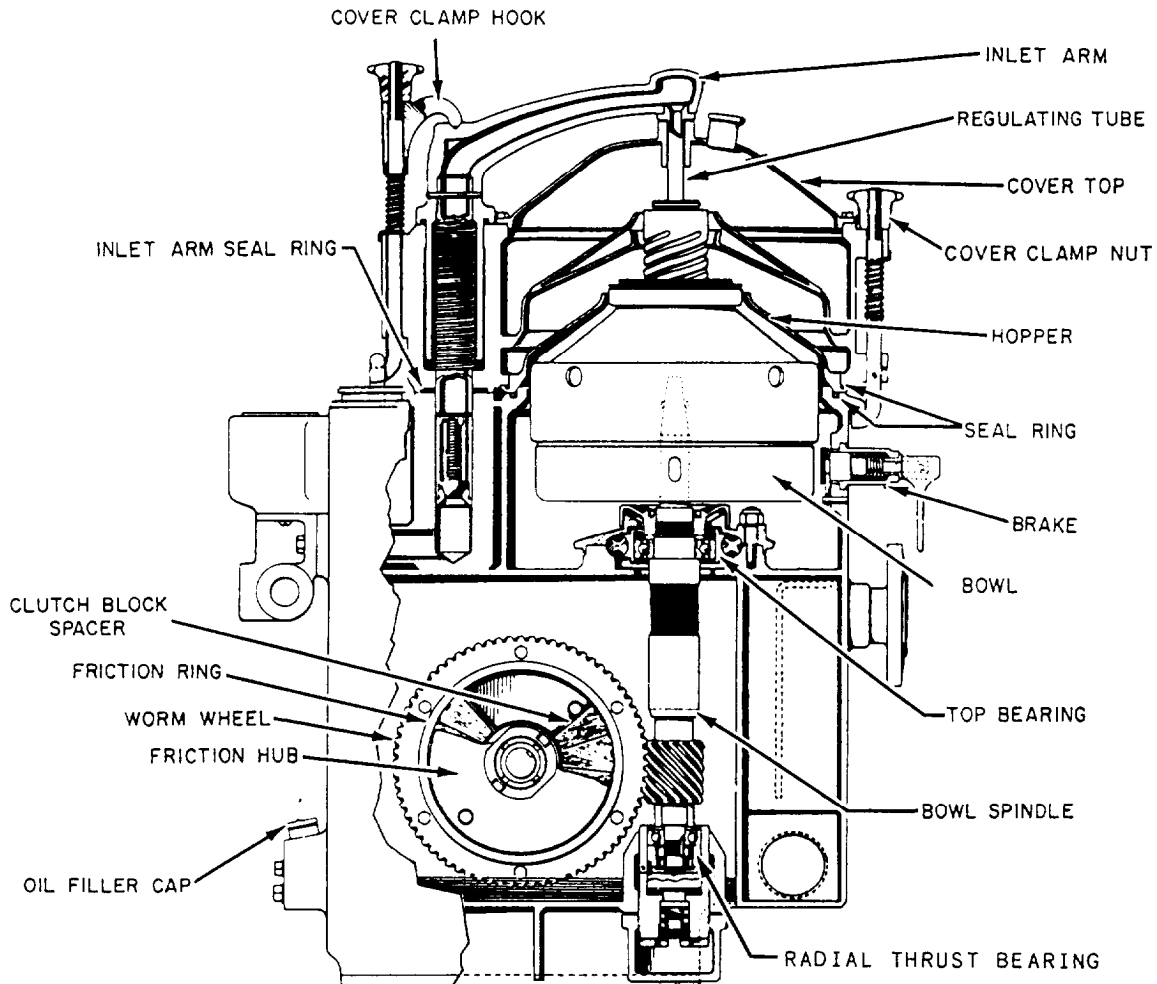

Figure 10-33.—Disc-type centrifugal purifier.

the lube oil is discharged to the sump. The solids remain in the rotating unit.

Other factors that affect separation by centrifugal force include the size of the particles, the viscosity of the fluids, and the length of time the materials are subjected to centrifugal force. Generally, the greater the difference in specific gravity between the substances to be separated and the lower the viscosity of the lube oil, the greater the rate of separation.

**PURIFIER TYPES**

Two basic types of purifiers are used in Navy installations, and both types use centrifugal force. There are principal differences in the equipment design and operating speed of the rotating elements of the two machines. In one type, the rotating element is a bowl-like container that encases a stack of discs. This is the disc-type DeLaval purifier, which has a bowl operating speed of about 7,200 rpm. In the other type, the rotating element is a hollow cylinder. This machine is the tubular-type Sharples purifier, which has an operating speed of 15,000 rpm.

**Disc-Type Purifier**

Figure 10-33 shows a cutaway view of a disc-type centrifugal purifier. The bowl is mounted on the upper end of the vertical bowl spindle, and driven by a worm wheel and friction clutch assembly. A radial thrust bearing at the lower end of the bowl spindle carries the weight of the bowl spindle and absorbs any thrust created by the driving action. Figure 10-34 shows the

parts of a disc-type bowl. The flow of fluid through the bowl and additional parts are shown in figure 10-35. Contaminated fluid enters the top of the revolving bowl through the regulating tube. The fluid then passes down the inside of the tubular shaft, out the bottom, and up into the stack of discs. As the dirty fluid flows up through the distribution holes in the discs, the high centrifugal force exerted by the revolving bowl causes the dirt, sludge, and water to move outward. The purified fluid is forced inward and upward, discharging from the neck of the top disc. The water forms a seal between the top disc and the bowl top. (The top disc is the dividing line between the water and the fluid.) The discs divide the space within the bowl into many separate narrow passages or spaces. The liquid confined within each pass is restricted so that it flows only along that pass. This arrangement minimizes agitation of the liquid passing through the bowl. It also forms shallow settling distances between the discs.

Any water separated from the fluid, along with some dirt and sludge, is discharged through the discharge ring at the top of the bowl. However, most of the dirt and sludge remains in the bowl and collects in a more or less uniform layer on the inside vertical surface of the bowl shell.

**Tubular-Type Purifier**

A cutaway view of a tubular-type centrifugal purifier is shown in figure 10-36. This type of purifier consists of a bowl or hollow rotor that rotates at high speeds. The bowl has an opening in the bottom to allow the dirty fluid to enter. It also has two sets of openings

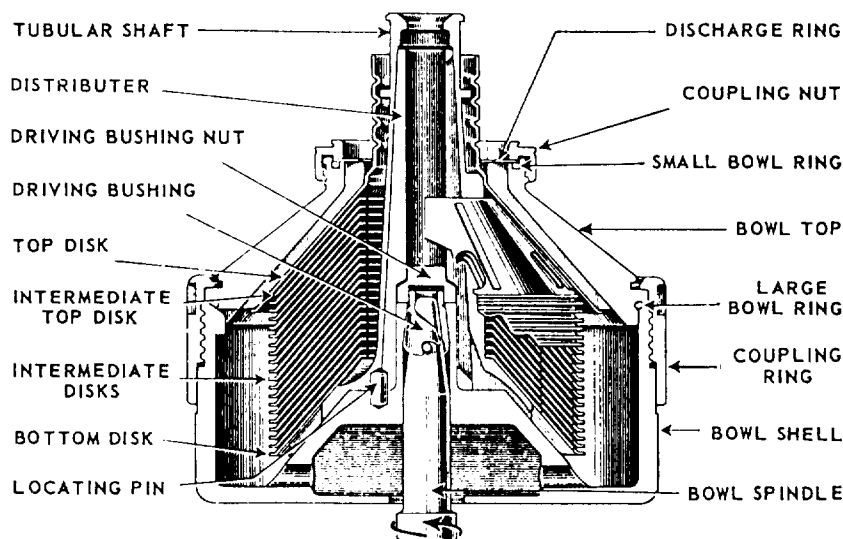

Figure 10-34.—Parts of a disc-type purifier bowl.

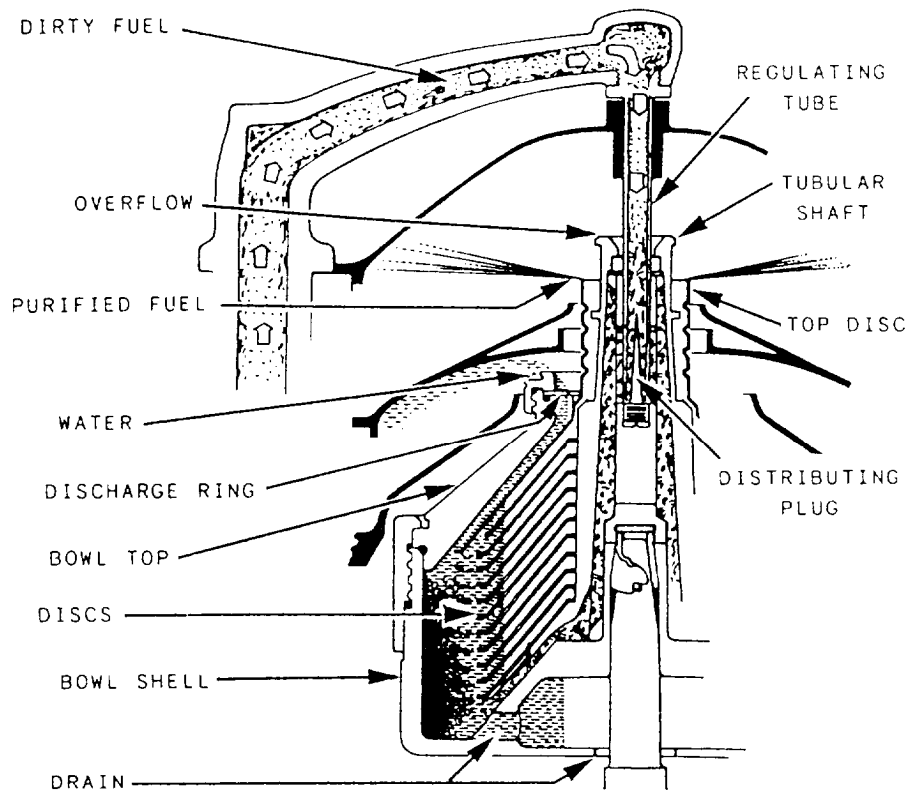

Figure 10-35.—Path of contaminated oil through a disc-type purifier bowl (Delaval).

at the top to allow the fluid and water to discharge. The bowl of the purifier is connected by a coupling unit to a spindle. The spindle is suspended from a ball bearing assembly. The bowl is belt-driven by an electric motor mounted on the frame of the purifier.

The lower end of the bowl extends into a flexibly mounted guide bushing. The assembly restrains movement of the bottom of the bowl, but it also allows the bowl enough movement to center itself during operation. Inside the bowl is a device with three flat plates that are equally spaced radially. This device is commonly referred to as the THREE-WING DEVICE, or just the three-wing. The three-wing rotates with the bowl and forces the liquid in the bowl to rotate at the same speed as the bowl. The liquid to be centrifuged is fed, under pressure, into the bottom of the bowl through the feed nozzle.

After priming the bowl with water, separation is basically the same as it is in the disc-type purifier. Centrifugal force causes clean fluid to assume the innermost position (lowest specific gravity), and the higher density water and dirt are forced outward towards the sides of the bowl. Fluid and water are discharged from separate openings at the top of the bowl. The location of the fluid-water interface within the bowl is

determined by the size of a metal ring called a RING DAM or by the setting of a discharge screw. The ring dam or discharge screw is also located at the top of the bowl. Any solid contamination separated from the liquid remains inside the bowl all around the inner surface.

#### GENERAL NOTES ON PURIFIER OPERATIONS

For maximum efficiency, you should operate purifiers at the maximum designed speed and rated capacity. Since reduction gear oils are usually contaminated with water condensation, the purifier bowls should be operated as separators and not as clarifiers.

When a purifier is operated as a separator, you should **prime the bowl** with fresh water **before** any oil is admitted into the purifier. The water seals the bowl and creates an initial equilibrium of liquid layers. If the bowl is not primed, the oil is lost through the water discharge port.

There are many factors that influence the time required for purification and the output of a purifier, such as the

1. viscosity of the oil,

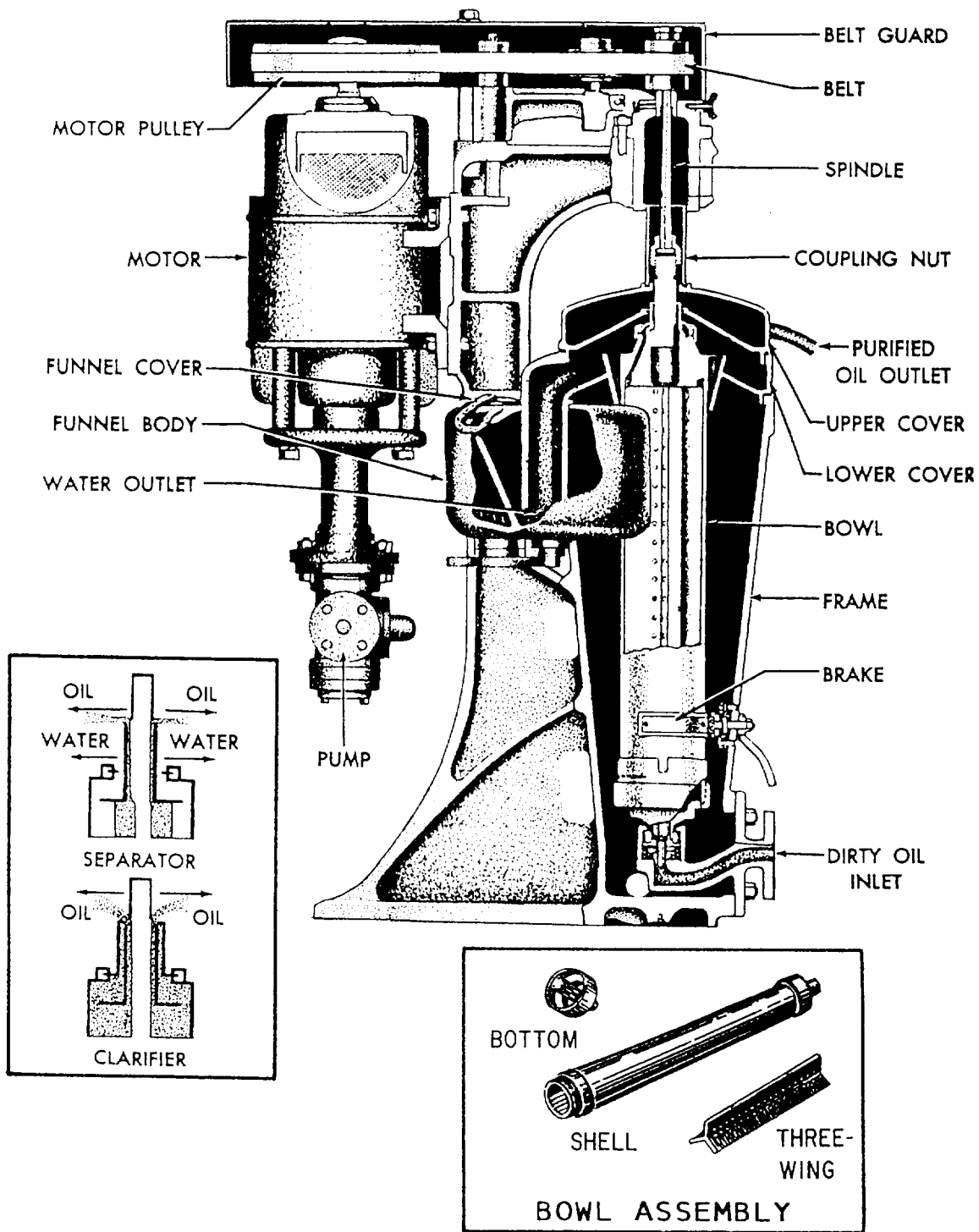

Figure 10-36. Tubular-type centrifugal purifier.

2. pressure applied to the oil,
3. size of the sediment particles,
4. difference in the specific gravity of the oil,
5. substances that contaminate the oil, and
6. tendency of the oil to emulsify.

The viscosity of the oil will determine the length of time required to purify the oil. The more viscous the oil, the longer the time will be to purify it to a given degree of purity. Heating decreases the viscosity of the oil, and this is one of the most effective methods to make purification easier.

Even though certain oils may be satisfactorily purified at operating temperatures, a greater degree of purification generally results if the oil is heated to a higher temperature. To do this, the oil is passed through a heater where the proper temperature is obtained before the oil enters the purifier bowl.

Oils used in naval ships maybe heated to specified temperatures without adverse effects. However, prolonged heating at higher temperatures is not recommended because of the tendency of such oils to oxidize. Oxidation results in rapid deterioration. Generally, heat oil to produce a viscosity of approximately 90 seconds Saybolt universal (90 SSU).

You should NEVER increase the pressure above normal to force a high-viscosity oil through the purifier. Instead, decrease the viscosity by heating the oil. Using excess pressure to force oil through the purifier results in less efficient purification. On the other hand, reducing the pressure at which the oil is forced into the purifier increases the length of time the oil is under the influence of centrifugal force and results in improved purification.

To make sure that the oil discharged from a purifier is free of water, dirt, and sludge, you need to use the proper size discharge ring (ring dam). The size of the discharge ring depends on the specific gravity of the oil being purified. All discharge rings have the same outside diameter; but, they have inside diameters of different sizes.

The information in this TRAMAN on purifiers is general, and it applies to both types of purifiers. Before you operate a specific purifier, refer to the specific operating procedures contained in the instructions that come with the unit.

### **ELECTROHYDRAULIC DRIVE MACHINERY**

Hydraulic units drive or control steering gears, windlasses, winches, capstans, airplane cranes, ammunition hoists, and distant control valves. In this part of the chapter, you will learn about some of the hydraulic units that will concern you.

The electrohydraulic type of drive operates several different kinds of machinery better than other types of drives. Here are some of the advantages of electrohydraulic machinery.

- Tubing, which can readily transmit fluids around corners, conducts the liquid which transmits the force. Tubing requires very little space.

- The machinery operates at variable speeds.
- Operating speed can be closely controlled from minimum to maximum limits.
- The controls can be shifted from no load to full load rapidly without damage to machinery.

### **ELECTROHYDRAULIC SPEED GEAR**

An electrohydraulic speed gear is frequently used in electrohydraulic applications. Different variations of the basic design are used for specific applications, but the operating principles remain the same. Basically, the unit consists of an electric motor-driven hydraulic pump (A-end) and a hydraulic motor (B-end).

The B-end (fig. 10-37) is already on stroke and is rotated by the hydraulic force of the oil acting on the pistons. Movement of the pistons' A-end is controlled by a tilt box (also called a swash plate) in which the socket ring is mounted, as shown in part A of figure 10-37.

The length of piston movement, one way or the other, is controlled by movement of the tilt box and by the amount of angle at which the tilt box is placed. The length of the piston movement controls the amount of fluid flow. When the drive motor is energized, the A-end is **always** in motion. However, with the tilt box in a neutral or vertical position, there is no reciprocating motion of the pistons. Therefore, no oil is pumped to the B-end. Any movement of the tilt box, no matter how slight, causes pumping action to start. This causes immediate action in the B-end because force is transmitted by the hydraulic fluid.

When you need reciprocating motion, such as in a steering gear, the B-end is replaced by a piston or ram. The force of the hydraulic fluid causes the movement of the piston or ram. The tilt box in the A-end is controlled locally (as on the anchor windlass) or remotely (as on the steering gear).

### **ELECTROHYDRAULIC STEERING GEAR**

The steering gear transmits power from the steering engine to the rudder stock. The steering gear frequently includes the driving engine and the transmitting mechanism.

Many different designs of steering gear are in use, and they all operate on the same principle. One type of



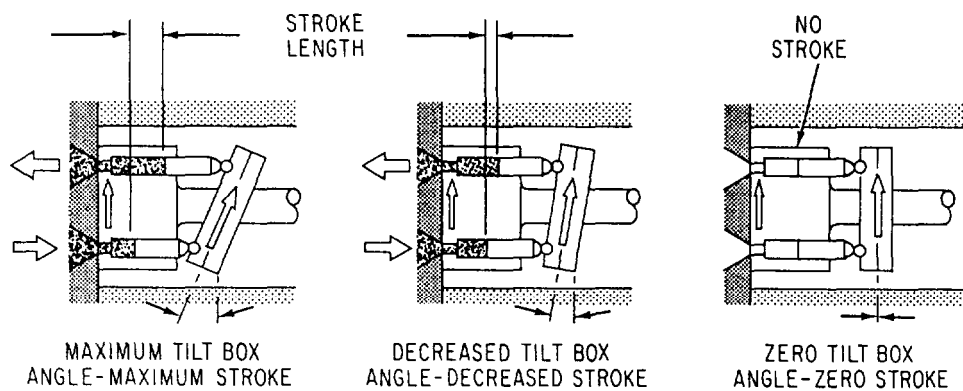

A OPERATION OF  
A-END TILT BOX

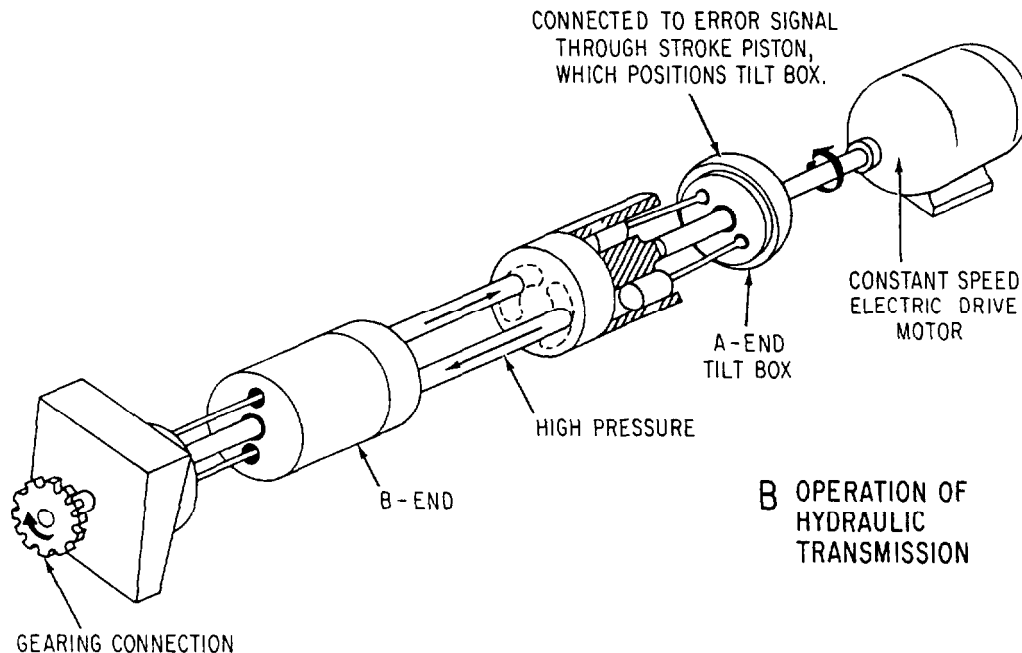

B OPERATION OF  
HYDRAULIC  
TRANSMISSION

Figure 10-37.—Electrohydraulic speed gear.

electrohydraulic steering gear is shown in figure 10-38. It consists essentially of a ram unit and a power unit.

### Ram Unit

The ram unit (view A) is mounted athwartship and consists of a single ram operated by opposed cylinders. The ram is connected by links to the tillers of the twin rudders. When oil pressure is applied to one end of the operating cylinder, the ram moves, causing each rudder to move along with it. Oil from the opposite end of the cylinder is returned to the suction side of the main hydraulic pump in the power unit.

### Power Unit

The power unit (view B) consists of two independent pumping systems. Two systems are used

for reliability. One pump can be operated while the other is on standby.

Each pumping system consists of a variable-delivery, axial-piston main pump and a vane-type auxiliary pump. Both are driven by a single electric motor through a flexible coupling. Each system also includes a transfer valve with operating gear, relief valves, a differential control box, and trick wheels. The whole unit is mounted on a bedplate that serves as the top of an oil reservoir. Steering power is taken from either of the two independent pumping systems.

The pumps of the power unit are connected to the ram cylinders by high-pressure piping. The two transfer valves are placed in the piping system to allow for the lineup of one pump to the ram cylinders with the other pump isolated. A hand lever and mechanical link (not shown) are connected to the two transfer valves so that

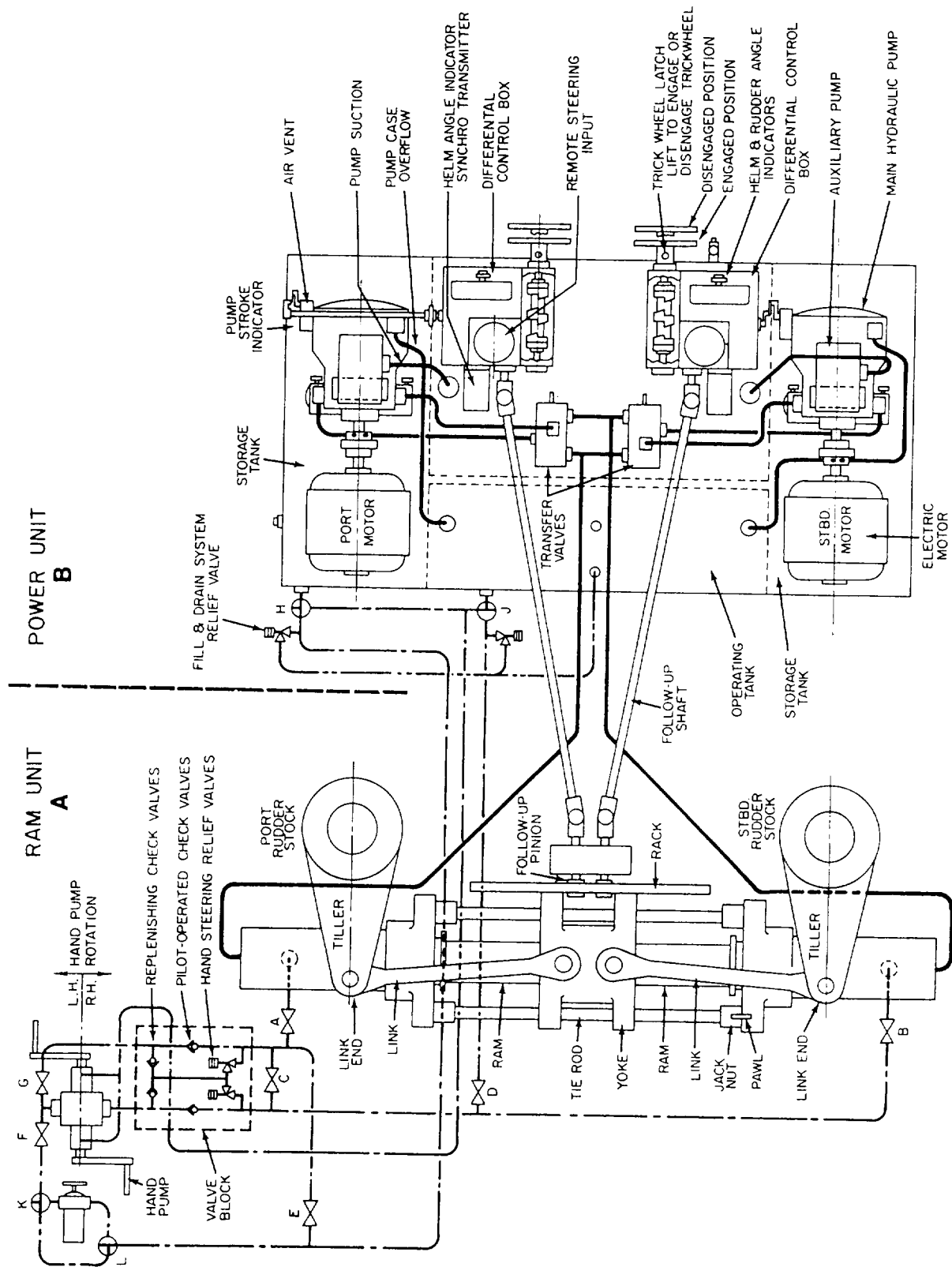

Figure 10-38.—Electrohydraulic steering gear. A. Ram unit. B. Power unit.

both valves are operated together. This allows rapid shifting from the on-service pumping unit to the standby unit; it prevents lining up both pumps to the ram at the same time. The hand lever is usually located between the trick wheels. It has three positions marked **P**, **N**, and **S**. **P** denotes the port pump is connected to the ram; **N** denotes neutral (neither pump connected to the ram); and **S** denotes the starboard pump is connected to the ram. Also, the hand lever is usually connected to motor switches. This lets the operator connect the selected pump to the ram and start the pump drive motor in one quick operation. In most ships this valve is electrically controlled by the motor controller and by pressure switches.

### Principles of Operation

The on-service hydraulic pump is running at all times and is a constant-speed pump. Unless steering is actually taking place, the tilt box of the main hydraulic pump is at zero stroke, and no oil is being moved within the main system. The auxiliary pump provides control oil and supercharge flows for the system.

To understand the operation of the pump, let's assume that a steering order signal comes into the differential control box. It can come from either the remote steering system in the ship's wheelhouse or the trick wheel. The control box mechanically positions the tilt box of the main hydraulic pump to the required angle and position.

**NOTE:** Remember that direction of fluid and flow may be in either direction in a hydraulic speed gear. It depends on which way the tilt box is angled. For this reason, the constant-speed, unidirectional motor can be used to drive the main hydraulic pump. The pump will still have the capability to drive the ram in either direction.

With the main hydraulic pump now pumping fluid into one of the ram cylinders, the ram moves, moving the rudders. A rack and gear are attached to the rudder yoke between the rudder links. As the ram and the rudder move, the rack gear moves, driving the follow-up pinion gear. The pinions drive follow-up shafts that feed into the differential box. This feedback or servo system tells the differential control box when the steering operation is complete. As the ordered rudder angle is approached, the differential control box begins realigning the tilt box of the main hydraulic pump. By the time the desired rudder angle is reached, the tilt box is at zero stroke. This means that the ordered signal (from the pilot house or trick wheel) and the actual signal (from the follow-up

shafts) are the same. If either of these change, the differential control box reacts accordingly; the main hydraulic unit pumps oil to one end or the other of the ram.

The trick wheels provide local-hydraulic control of the steering system of the remote steering system fails. A hand pump and associated service lines are also provided for local-manual operation of the ram if both hydraulic pump units fail.

### Operation and Maintenance

The Machinist's Mate watch stander usually operates the steering equipment only in abnormal and emergency situations. For this reason, you should be thoroughly familiar with all emergency procedures, such as local-hydraulic steering with the trick wheel and local-manual steering with the hand pump. Operating instructions and system diagrams are normally posted near the steering gear. The diagrams describe the various procedures and lineups for operation of the steering gear. Be sure that the standby equipment is ready for instant use.

General maintenance of the steering gear requires that you clean, inspect, and lubricate the mechanical parts and maintain the hydraulic oil at the proper level and purity. The Planned Maintenance System (PMS) lists the individual requirements for the equipment. The electricians maintain the electrical portion of the steering system, including the control system.

### ANCHOR WINDLASSES

In a typical electrohydraulic mechanism, one constant-speed electric motor drives two variable-stroke pumps through a coupling and reduction gear. Other installations include two motors, one for driving each pump. Each pump normally drives one wildcat. However, if you use a three-way plug cock-type valve, either pump may drive either of the two wildcats. The hydraulic motors drive the wildcat shafts with a multiple-spur gearing and a locking head. The locking head allows you to disconnect the wildcat shaft and permits free operation of the wildcat, as when dropping anchor.

Each windlass pump is controlled either from the weather deck or locally. The controls are handwheels on shafting that lead to the pump control. The hydraulic system requires your attention. Make sure the hydraulic system is always serviced with the specified type of clean oil.

Normally, you will maintain three types of anchor windlasses—the electric, electrohydraulic, and hand-driven windlasses. Hand-driven windlasses are used only on small ships where the anchor gear can be handled without excessive effort by operating personnel.

The major work on a hand windlass is to properly adjust the link, friction shoes, locking head, and brake and to keep them in satisfactory operating condition at all times. In an electrohydraulic windlass, your principal concern is the hydraulic system.

A windlass is used intermittently and for short periods of time. However, it must handle the required load under severe conditions. This means that you must maintain and adjust the machinery when it is not in use. This practice will prevent deterioration and ensure dependable use.

Windlass brakes must be kept in satisfactory condition if they are to function properly. Wear and compression of brake linings increases the clearance between the brake drum and band after a windlass has been in operation. Inspect brake linings and clearances frequently. Make adjustments according to the manufacturer's instructions.

You should follow the lubrication instructions furnished by the manufacturer. If a windlass has been idle for some time, lubricate it. This protects finished surfaces from corrosion and prevents seizure of moving parts.

The hydraulic transmissions of electrohydraulic windlasses and other auxiliaries are manufactured with close tolerances between moving and stationary parts. Keep dirt and other abrasive material out of the system. When the system is replenished or refilled, use only clean oil. Strain it as it is poured into the tank. If a hydraulic transmission is disassembled, clean it thoroughly before reassembly. Before installing piping or valves, clean their interiors to remove any scale, dirt, preservatives, or other foreign matter.

## **WINCHES**

Winches are used to heave in on mooring lines, to hoist boats, as top lifts on jumbo booms of large auxiliary ships, and to handle cargo. Power for operating shipboard winches is usually furnished by electricity and, on some older ships, by steam. Sometimes delicate control and high acceleration without jerking are required, such as for handling aircraft. Electrohydraulic winches are usually installed for this purpose. Most

auxiliary ships are equipped with either electrohydraulic or electric winches.

## **Cargo Winches**

Some of the most common winches used for general cargo handling are the double-drum, double-gypsy, and the single-drum, single-gypsy units. Four-drum, two-gypsy machines are generally used for minesweeping.

## **Electrohydraulic Winches**

Electrohydraulic winches (fig. 10-39) are always drum type. The drive equipment is like most hydraulic systems. A constant-speed electric motor drives the A-end (variable-speed hydraulic pump), which is connected to the B-end (hydraulic motor) by suitable piping. The drum shaft is driven by the hydraulic motor through reduction gearing.

Normally, winches have one horizontally mounted drum and one or two gypsy heads. If only one gypsy is required, it is easily removed from or assembled on either end of the drum shaft. When a drum is to be used, it is connected to the shaft by a clutch.

## **Electric Winches**

An electrically driven winch is shown in figure 10-40. This winch is a single-drum, single-gypsy type. The electric motor drives the unit through a set of reduction gears. A clutch engages or disengages the drum from the drum shaft. Additional features include an electric brake and a speed control switch.

## **CAPSTANS**

The terms capstan and winch should not be confused. A winch has a horizontal shaft and a capstan has a vertical shaft. The type of capstan installed aboard ship depends on the load requirements and type of power available. In general, a capstan consists of a single head mounted on a vertical shaft, reduction gearing, and a power source. The types, classified according to power source, are electric and steam. Electric capstans are usually of the reversible type. They develop the same speed and power in either direction. Capstans driven by ac motors run at either full, one-half, or one-third speed. Capstans driven by dc motors usually have from three to five speeds in either direction of rotation.

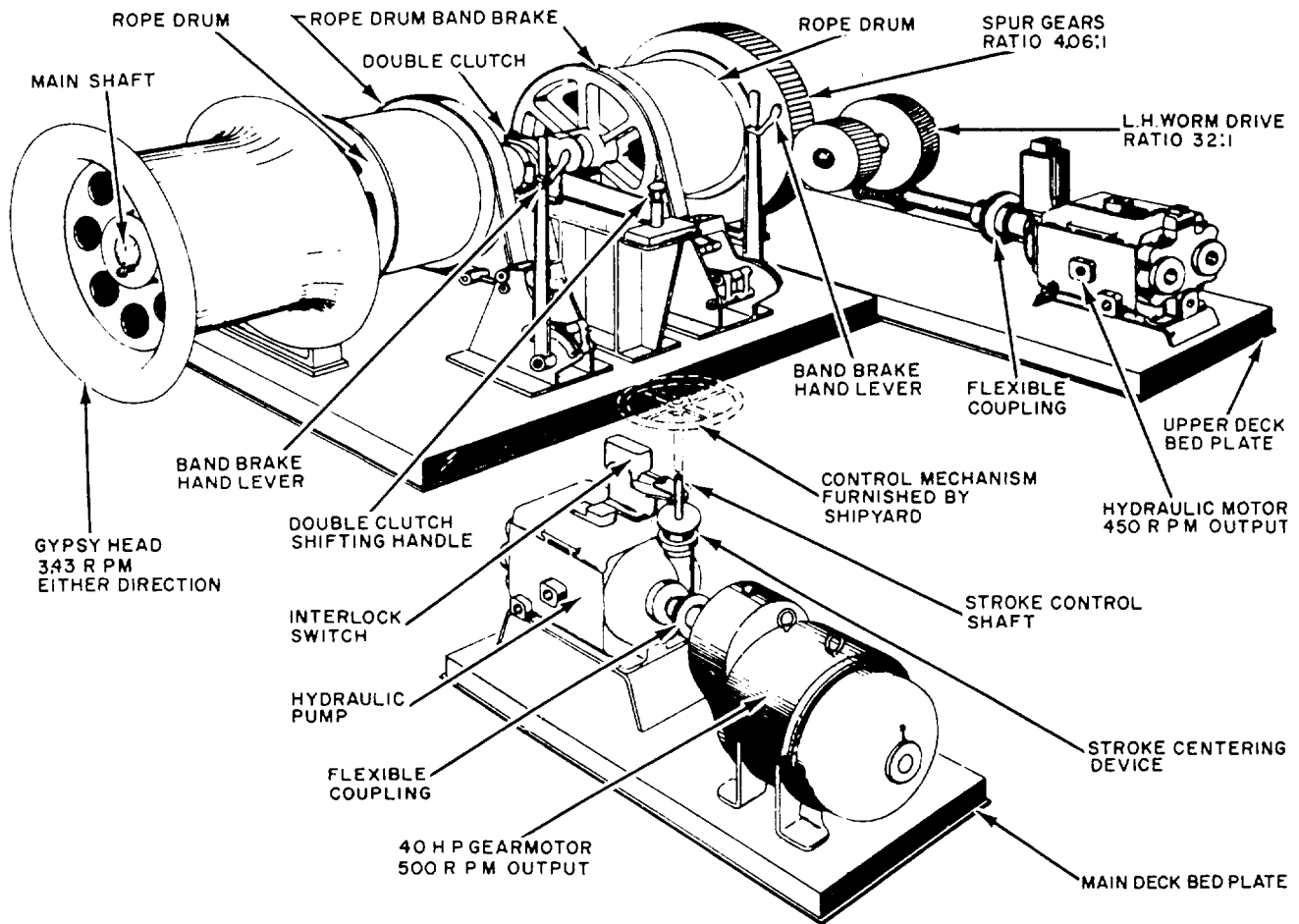

Figure 10-39.—Electrohydraulic winch units.

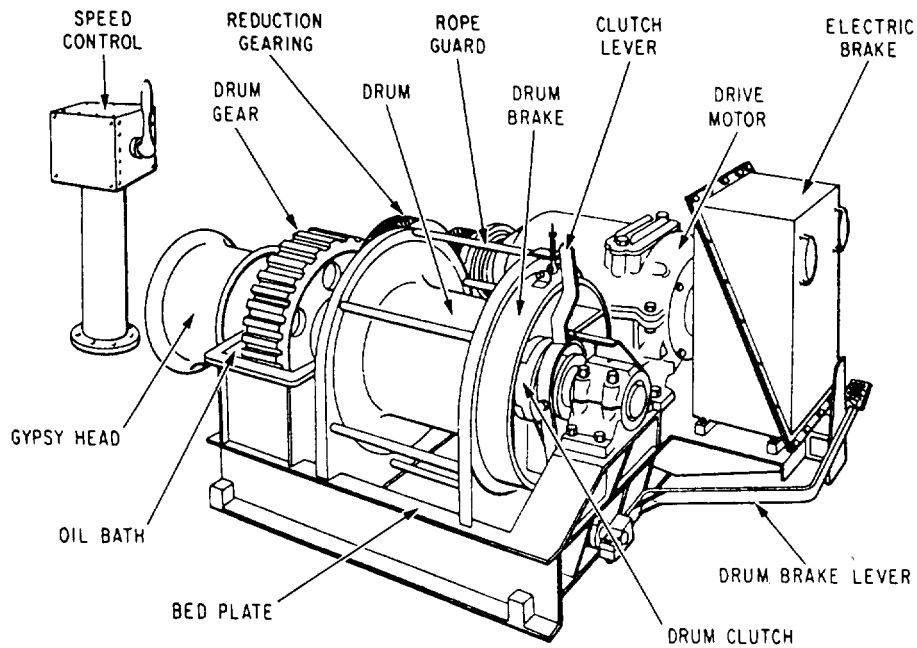

Figure 10-40.—Electric winch.

## **Maintenance of Winches and Capstans**

You will maintain the winch or capstan similarly. Where band brakes are used on the drums, inspect the friction linings regularly and replace them when necessary. Take steps to prevent oil or grease from accumulating on the brake drums. Check the operation of brake-actuating mechanisms, latches, and pawls periodically.

Inspect winch drums driven by friction clutches frequently for deterioration in the friction material. Check also to see if oil and grease are preventing proper operation. Lubricate the sliding parts of positive clutches properly. Check the locking device on the shifting gear to see if it will hold under load.

## **CRANES**

Cranes are designed to meet the following criteria:

1. Hoist, lower, top, and rotate a rated load at the specified speed and against a specified list of the ship.
2. Handle 150 percent of rated load at no specified speed.
3. Withstand a static, suspended load of 200 percent of rated load without dam or distortion to any part of the crane or structure.

The types of cranes installed on ships vary according to the equipment handled.

The crane equipment generally includes the boom, king post, king post bearings, sheaves, hook and rope, machinery platforms, rotating gear, drums, hoisting, topping and rotating drives, and controls. Some of the components of cranes include booms, king post bearings, sheaves and ropes, machinery platforms, rotating gear and pinions, and drums.

### **Booms**

A boom, used as a mechanical shipboard appliance, is a structural unit used to lift, transfer, or support heavy weights. A boom is used with other structures or structural members that support it, and various ropes and pulleys, called blocks, which control it.

### **King Post Bearings**

Bearings on stationary king posts take both vertical load and horizontal strain at the collar, located at the top of the king post. On rotating king posts, bearings take

both vertical and horizontal loads at the base and horizontal reactions at a higher deck level.

### **Sheaves and Ropes**

The hoisting and topping ropes are led from the drums over sheaves to the head of the boom. The sheaves and ropes are designed according to recommendations by NAVSEASYSKOM. This command sets the criteria for selection of sheave diameter, size, and flexibility of the rope. Sufficient fair-lead sheaves are fitted to prevent fouling of the rope. A shock absorber is installed in the line, hoisting block, or sheave at the head of the boom to take care of shock stresses.

### **Machinery Platforms**

Machinery platforms carry the power equipment and operator's station. These platforms are mounted on the king post above the deck.

### **Rotating Gear and Pinions**

Rotation of the crane is accomplished by vertical shafts with pinions engaging a large rotating gear.

### **Drums**

The drums of the hoisting and topping winches are generally grooved for the proper size wire rope. The hoisting system uses single or multiple part lines as required. The topping system uses a multiple purchase as required.

### **Operation and Maintenance of Cranes**

The hoisting whips and topping lifts of cranes are usually driven by hydraulic variable-speed gears through gearing of various types. This provides the wide range of speed and delicate control required for load handling. The cranes are usually rotated by an electric motor connected to worm and spur gearing. They may also be rotated by an electric motor and hydraulic variable-speed gear connected to reduction gearing.

Some electrohydraulic cranes have automatic slack line take-up equipment. This consists of an electric torque motor geared to the drum. These cranes are used to lift boats, aircraft, or other loads from the water. The torque motor assists the hydraulic motor drive to reel in the cable in case the load is lifted faster by the water than it is being hoisted by the crane.

Electrohydraulic equipment for the crane consists of one or more electric motors running at constant speed. Each motor drives one or more A-end variable-displacement hydraulic pumps. The pump strokes are controlled through operating handwheels. START, STOP, and EMERGENCY RUN pushbuttons at the operator's station control the electric motors. Interlocks prevent starting the electric motors when the hydraulic pumps are on stroke. B-end hydraulic motors are connected to the A-end pumps by piping. They drive the drums of the hoisting and topping units or the rotating machinery.

Reduction gears are located between the electric motor and the A-end pump and between the B-end hydraulic motor and the rotating pinion. Each hoisting, topping, and rotating drive has an electric brake on the hydraulic motor output shaft. This brake is interlocked with the hydraulic pump control. It will set when the hydraulic control is on neutral or when electric power is lost. A centering device is used to find and retain the neutral position of the hydraulic pump.

Relief valves protect the hydraulic system. These valves are set according to the requirements of chapter 556 of the NSTM.

Cranes usually have a rapid slack take-up device consisting of an electric torque motor. This motor is connected to the hoist drum through reduction gearing. This device works in conjunction with the pressure stroke control on the hydraulic pump. It provides fast acceleration of the hook in the hoisting direction under light hook conditions. Thus, slack in the cable is prevented when hoisting is started.

Some cranes have a light-hook paying-out device mounted on the end of the boom. It pays out the heisting cables when the weight of the hook and cable beyond the boom-head sheave is insufficient to overhaul the cable as fast as it is unreeled from the hoisting drum.

When the mechanical hoist control is in neutral, the torque motor is not energized and the cable is gripped lightly by the action of a spring. Moving the hoist control to LOWER energizes the torque motor. The sheaves clamp and pay out the cable as it is unreeled from the hoist drum. When the hoist control is moved to HOIST, the torque motor is reversed and unclamps the sheaves. A limit switch opens and automatically de-energizes the paying-out device.

Maintain cranes according to the PMS requirements or the manufactured instructions. Keep the oil in the replenishing tanks at the prescribed levels. Keep the system clean and free of air. Check the limit stop and

other mechanical safety devices regularly for proper operation. When cranes are not in use, secure them in their stowed positions. Secure all electric power to the controllers.

## **ELECTROHYDRAULIC ELEVATORS**

Some of the hydraulic equipment that you maintain is found in electrohydraulic elevator installations. Modern carriers use elevators of this type. The elevators described in this chapter are now in service in some of the ships of the CV class. These ships are equipped with four, deck-edge airplane elevators having a maximum lift capacity of 79,000 to 105,000 pounds. The cable lift platform of each elevator projects over the side of the ship and is operated by an electrohydraulic plant.

### **Electrohydraulic Power Plant**

The electrohydraulic power plant for the elevators consists of the following components:

1. A horizontal plunger-type hydraulic engine
2. Multiple variable-delivery parallel piston-type pumps
3. Two high-pressure tanks
4. One low-pressure tank
5. A sump tank system
6. Two constant-delivery vane-type pumps (sump pumps)
7. An oil storage tank
8. A piping system and valves
9. A nitrogen supply

The hydraulic engine is operated by pressure developed in a closed hydraulic system. Oil is supplied to the system in sufficient quantity to cover the baffle plates in the high-pressure tanks and allow for piston displacement. Nitrogen is used because air and oil in contact under high pressure form an explosive mixture. Air should not be used except in an emergency. Nitrogen, when used, should be kept at 97 percent purity.

The hydraulic engine has a balanced piston-type valve with control orifices and a differential control unit. This control assembly is actuated by an electric motor and can be operated by hand. To raise the elevator, move the valve off center to allow high-pressure oil to enter the cylinder. High-pressure oil entering the cylinder moves the ram. The ram works through a system of cables and sheaves to move the platform upward. The

speed of the elevator is controlled by the amount of pressure in the high-pressure tank and the control valve.

When the elevator starts upward, the pressure in the high-pressure tank drops. The pressure drop automatically starts the main pumps. These pumps transfer oil from the low-pressure tank to the high-pressure system until the pressure is restored. An electrical stopping device automatically limits the stroke of the ram and stops the platform at the proper position at the flight deck level.

To lower the elevator, move the control valve in the opposite direction. This lets oil in the cylinder flow into the exhaust tank. As the platform descends, oil is discharged to the low-pressure tank (exhaust tank). The original oil levels and pressures, except for leaks, are reestablished. The lowering speed is controlled by the control valve and the cushioning effect of the pressure in the exhaust tank. Leak is drained to the sump tanks. It is then automatically transferred to the pressure system by the sump pumps. An electrically operated stopping device automatically slows down the ram and stops the platform at its lower level (hangar deck).

### **Safety Features**

The following list contains some of the major safety features incorporated into modern deck-edge elevators:

1. If the electrical power fails while the platform is at the hangar deck, there will be enough pressure in the system to move the platform to the flight deck one time without the pumps running.

2. Some platforms have serrated safety shoes. If all the hoisting cable should break on one side, the shoes will wedge the platform between the guide rails. This will stop the platform with minimum damage.

3. A main pump may have a pressure-actuated switch to stop the pump motors when the discharge pressure is excessive. They may also have to relieve the pressure when the pressure switch fails to operate.

4. The sump pump system has enough capacity to return the unloaded platform from the hangar deck to the flight deck.

5. The oil filter system may be used continuously while the engine is running. This allows part of the oil to be cleaned with each operation of the elevator.

### **ELECTROMECHANICAL ELEVATORS**

Electromechanical elevators are used for freight, bombs, and stores. In this type of elevator, the platform

is raised and lowered by one or more wire ropes that pass over pulleys and wind or unwind on hoisting drums. Hoisting drums are driven through a reduction gear unit by an electric motor. An electric brake stops and holds the platform. The motor has two speeds, full speed and low, or one-sixth, speed. Control arrangements allow the elevator to start and run on high speed. Low speed is used for automatic deceleration as the elevator approaches the selected level. The platform travels on two or four guides. Hand-operated or power-operated lock bars, equipped with electrical interlocks, hold the platform in position.

### **LUBRICATING SYSTEMS**

Most equipment is provided with a lubricating system that supplies oil under pressure to the bearings. The system consists of a sump or reservoir for storing the oil, an oil pump, a strainer, a cooler, temperature and pressure gauges, and the necessary piping to carry the oil to the bearings and back to the sump. The location and arrangement of these parts vary with each piece of equipment. This system allows the lube-oil system to perform the following functions:

- Supply lubrication to the bearings
- Cool the bearings
- Flush any wear products from the bearings

The lube-oil pump is generally a gear-type pump. A definite pressure is maintained in the oil feed lines. A pressure relief valve allows excess oil to recirculate to the suction side of the pump.

Quite often, dual strainers are connected in the line so that the system can operate on one strainer while the other one is being cleaned. The tube-in-shell type of cooler is generally used with seawater circulating through the tubes and the oil flowing around them. The temperature of the oil is controlled by adjusting the valve that regulates the amount of seawater flowing through the tubes.

Oil must be supplied to the bearings at the prescribed pressure and within certain temperature limits. A pressure gauge installed in the feed line and a thermometer installed in the return line indicate oil system functioning. Thermometers are often installed in the bearings to serve as a warning against overheating. If there is a decided drop in oil pressure, shut down the equipment immediately. You should investigate even a moderate rise in the oil temperature. An oil-level float gauge indicates the amount of oil in the sump. Some bearings do not require a lot of cooling or flushing of



wear products, so they are grease lubricated (like automobile steering joints). These bearings are usually fitted with a zerk fitting (grease fitting), but some may have grease cups installed.

## FUNCTIONS OF LUBRICATION

Lubrication reduces friction between moving parts by substituting fluid friction for sliding friction. Most lubricants are oils or greases; but other units, such as water, can be used for lubrication. When a rotating journal is set in motion, a wedge of oil is formed. This wedge (layer of oil) supports the rotor and substitutes fluid friction for sliding friction. The views shown in figure 10-41 represent a rotor (journal) rotating in a solid sleeve-type bearing. The clearances are exaggerated in the drawing so you can see the formation of the oil film. The shaded portion represents the clearance filled with oil. While the journal is stopped, the oil is squeezed from between the rotor and the bearing. As the rotor starts to turn, oil adhering to the rotor surfaces is carried into the area between the rotor and the bearing. This oil increases the thickness of the oil film, tending to raise and support the rotor. Thus, sliding friction has been replaced by fluid friction.

## LUBRICATING OILS AND GREASES

Many different kinds of lubricating materials are in use, each of them filling the requirements of a particular set of conditions. Animal and vegetable oils and even water have good lubricating qualities, but they cannot withstand high temperatures. Mineral oils, similar to the oils used in an automobile engine, are the best type of

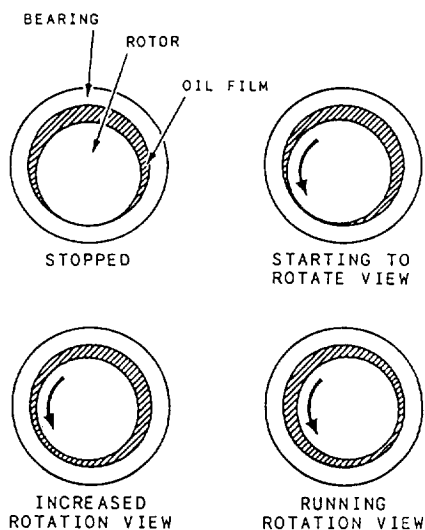

Figure 10-41.—Rotating journals in sleeve-type bearings.

lubricant for modern machinery operating at high speeds and high temperatures.

Mineral lubricating oils are derived from crude oil in the same process that produces gasoline, kerosene, and fuel oil. They vary according to the type of crude oil and the refining methods used. The same type of oil is usually made in several grades or weights. These grades correspond to the different weights of oil for an automobile, varying from light to heavy.

Oils used in the Navy are divided into nine classes, or series, depending on their use. Each type of oil has a symbol number that indicates its class and viscosity. For example, symbol 2190 oil is a number 2 class of oil with a viscosity of 190 SSU. The viscosity number represents the time in seconds that is required for 60 cubic centimeters (cc) of oil, at a temperature of 130°F, to flow through a standard size opening in a Saybolt viscosimeter (fig. 10-42).

A 2190TEP oil is used for all propulsion turbines and reduction gears. The letters **TEP** indicate that the oil contains additive materials that increase its ability to displace water from steel and inhibit oxidation.

Internal combustion engines (gasoline and diesel) use symbol 9110, 9170, 9250, or 9500 lubricating oils.

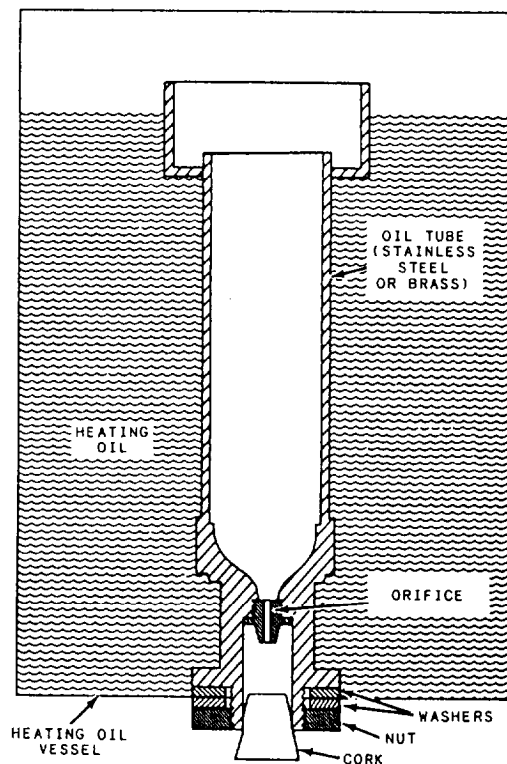

Figure 10-42.—Viscosimeter tube.

These oils have been developed for lubrication of high-speed, high-output diesel engines.

Grease lubrication is used in locations where the retention of lube oil would be difficult. Some of these locations include throttle links, pump bearings, small boat steering links, laundry equipment, etc. Grease is graded according to its intended use and the additives it may contain. Always be sure that you are using the specified lubricant for the individual machinery part, unit, or system you are responsible for operating or maintaining.

The manufacturer's technical manual for each unit of machinery is the basic reference for the correct lube oil, if no lubrication chart (based on manufacturer's instructions) is available. In addition, the table of recommended oils can be found in NSTM, chapter 262.

## **GALLEY AND LAUNDRY EQUIPMENT**

The Navy uses a variety of galley and laundry equipment. The type of equipment depends on the size of the ship, the availability of steam, and other factors. You will need the equipment manufacturer's technical manual for each different piece of gear aboard. Schedule and perform preventive maintenance according to the 3-M systems.

### **GALLEY EQUIPMENT**

In the following paragraphs, we will discuss some of the types of galley equipment with which you will deal.

#### **Steam-Jacketed Kettles**

Steam-jacketed kettles (fig. 10-43) come in sizes from 5 to 80 gallons. The kettles are made of corrosion-resisting steel. They operate at a maximum steam pressure of 45 psi. A relief valve in the steam line leading to the kettles is set to lift at 45 psi. Maintenance on these units is normally limited to the steam lines and valves associated with the kettles.

Other steam-operated cooking equipment includes steamers (fig. 10-44) and steam tables (fig. 10-45). Steamers use steam at a pressure of 5 to 7 psi; steam tables use steam at a pressure of 40 psi or less.

#### **Dishwashing Equipment**

Dishwashing machines used in the Navy are classified as one-, two-, or three-tank machines. The three-tank machine is a fully automatic, continuous

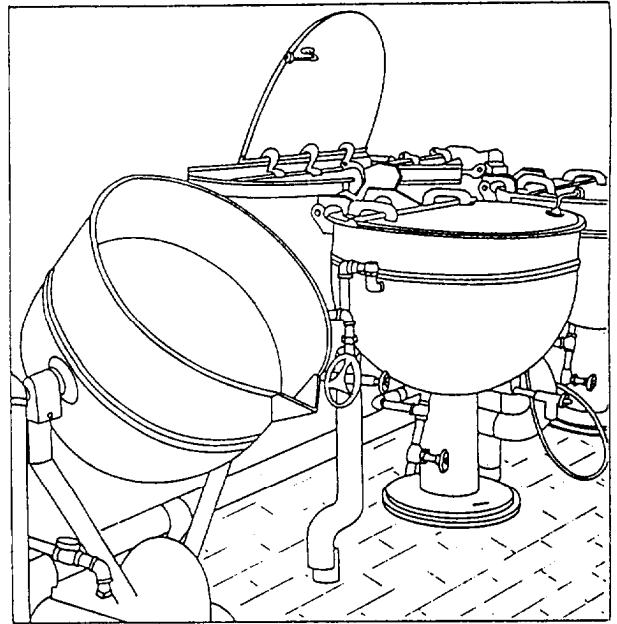

**Figure 10-43.—Steam-jacketed kettles**

racking machine. It scrapes, brushes, and provides two rinses. It is used at large activities.

Bacteria in these tanks must be controlled at a satisfactory level. This is done by controlling the temperature of the water. The temperature ranges will vary in one-, two- and three-tank machines.

**SINGLE TANK.**— Single-tank machines (fig. 10-46) are used on small ships, where larger models are not feasible.

The temperature of the washwater must be at least 140°F and no greater than 160°F. Lower temperatures will not control bacteria and higher temperatures are not efficient at removing some foods. These temperatures are controlled by a thermostat. The washing time is 40 seconds in the automatic machines.

For rinsing, hot water is sprayed on the dishes from an external source. It is controlled by an adjustable automatic steam-mixing valve that maintains the rinse water between 180°F and 195°F. To conserve fresh water, the rinse time interval is usually limited to 10 seconds. When water supply is not a problem, a rinse of 20 seconds is recommended.

Wash and rinse sprays are controlled separately by automatic, self-opening and closing valves in the automatic machine.

**DOUBLE TANK.**— Double-tank machines (fig. 10-47) are available in several capacities. They are used when more than 150 persons are to be served at one

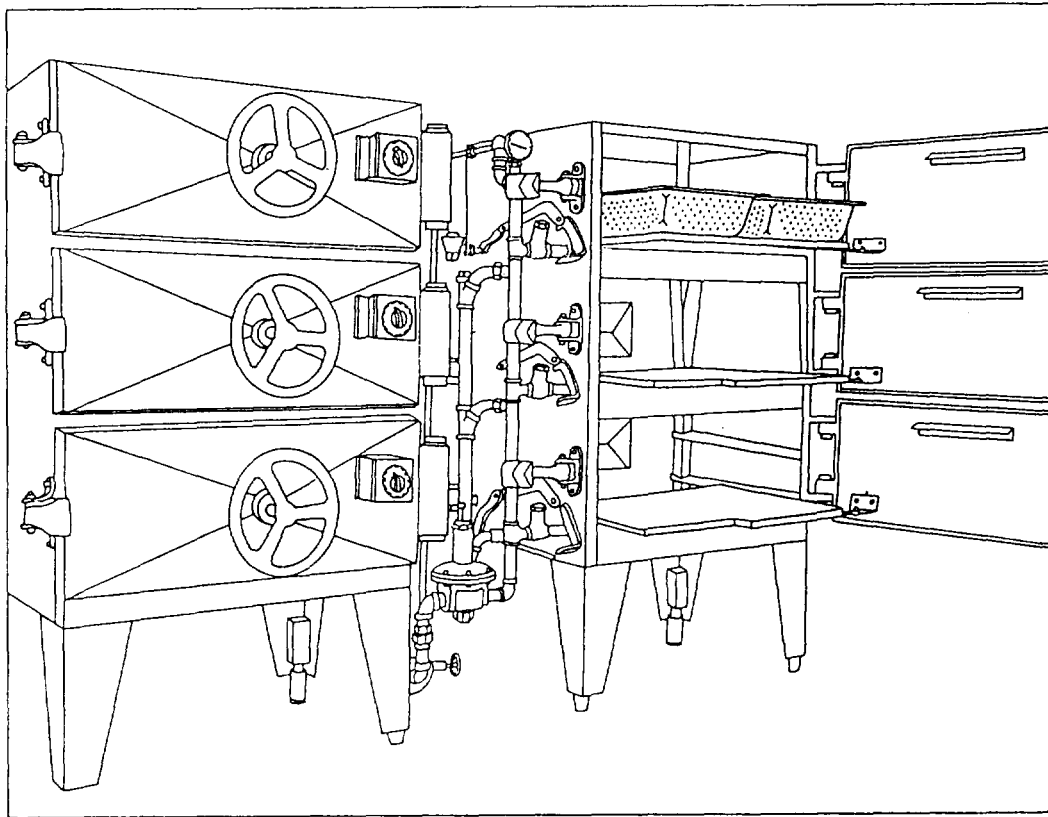

Figure 10-44.—Steamer.

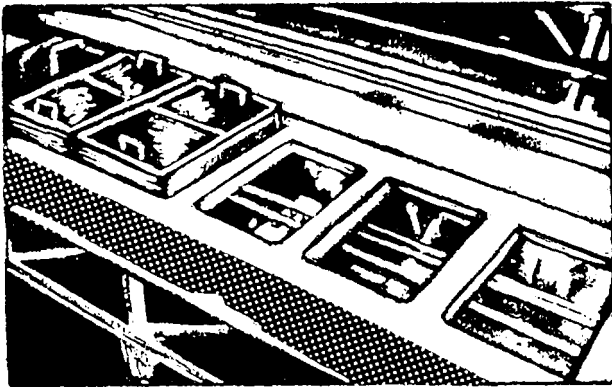

Figure 10-45.—Steam table.

meal. These machines have separate wash and rinse tanks. They also have a final rinse of hot water that is sprayed on the dishes from an outside source. This spray is opened by the racks as they pass through the machines. The spray automatically closes when the rinse cycle is completed. The final rinse is controlled by an adjustable automatic steam-mixing valve that maintains temperature between 180°F and 195°F. double-tank machines are also equipped with a

thermostatically operated switch in the rinse tank. This switch prevents operation of the machine if the temperature of the rinse water falls below 180°F. The racks pass through the machine automatically on conveyor chains. Utensils should be exposed to the machine sprays for not less than 40 seconds (20-second wash, 20-second rinse).

### Descaling Dishwashers

You should prevent the accumulation of scale deposits in dishwashing machines for at least two reasons. First, excessive scale deposit on the inside of pipes and pumps will clog them. This will interfere with the efficient performance of the machine by reducing the volume of water that comes in contact with the utensils during the washing and sanitizing process. Second, scale deposits provide a haven for harmful bacteria.

The supplies needed for descaling are available through Navy supply channels. See the following supply list:

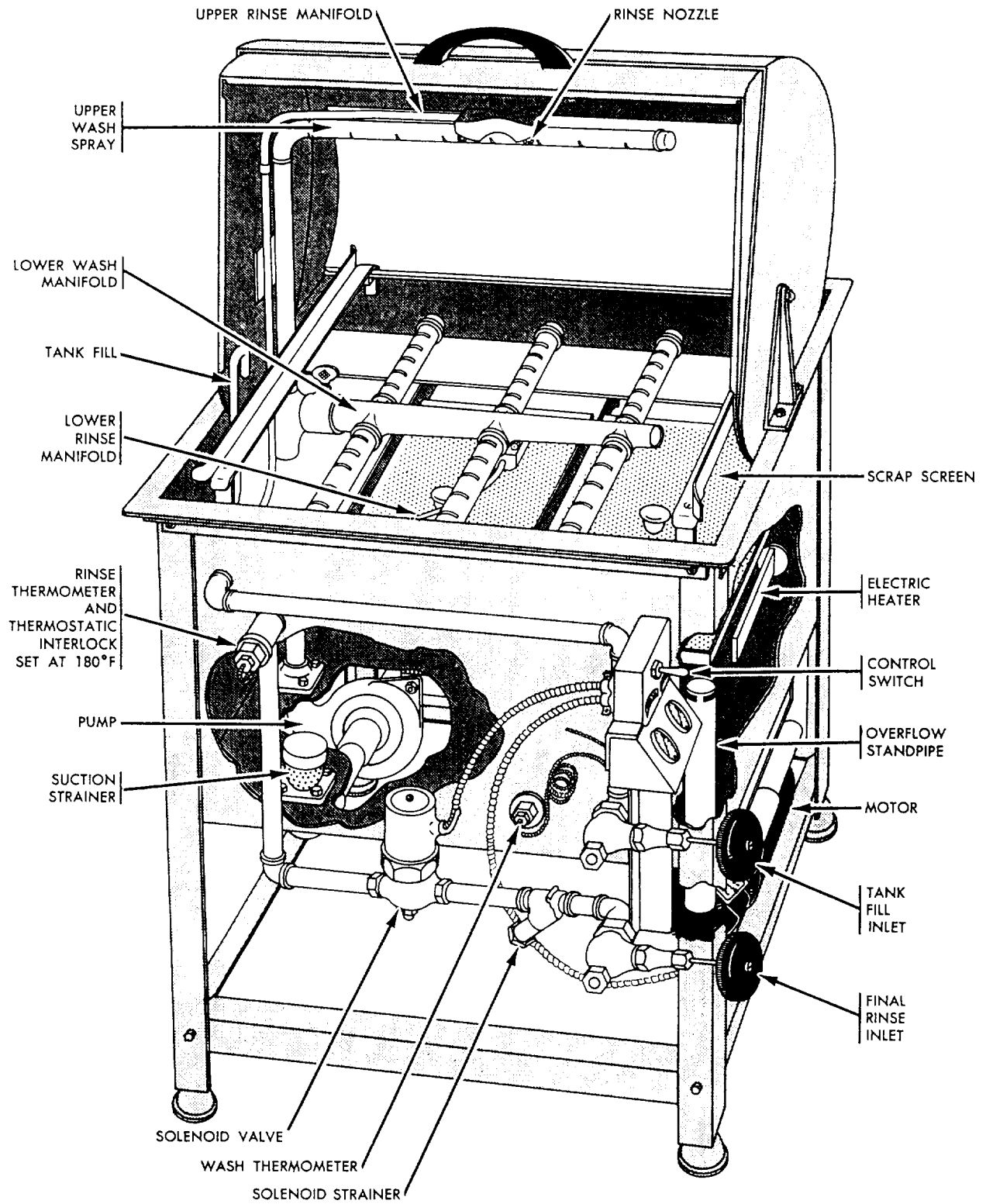

Figure 10-46.—Typical semiautomatic single-tank dishwashing machine.

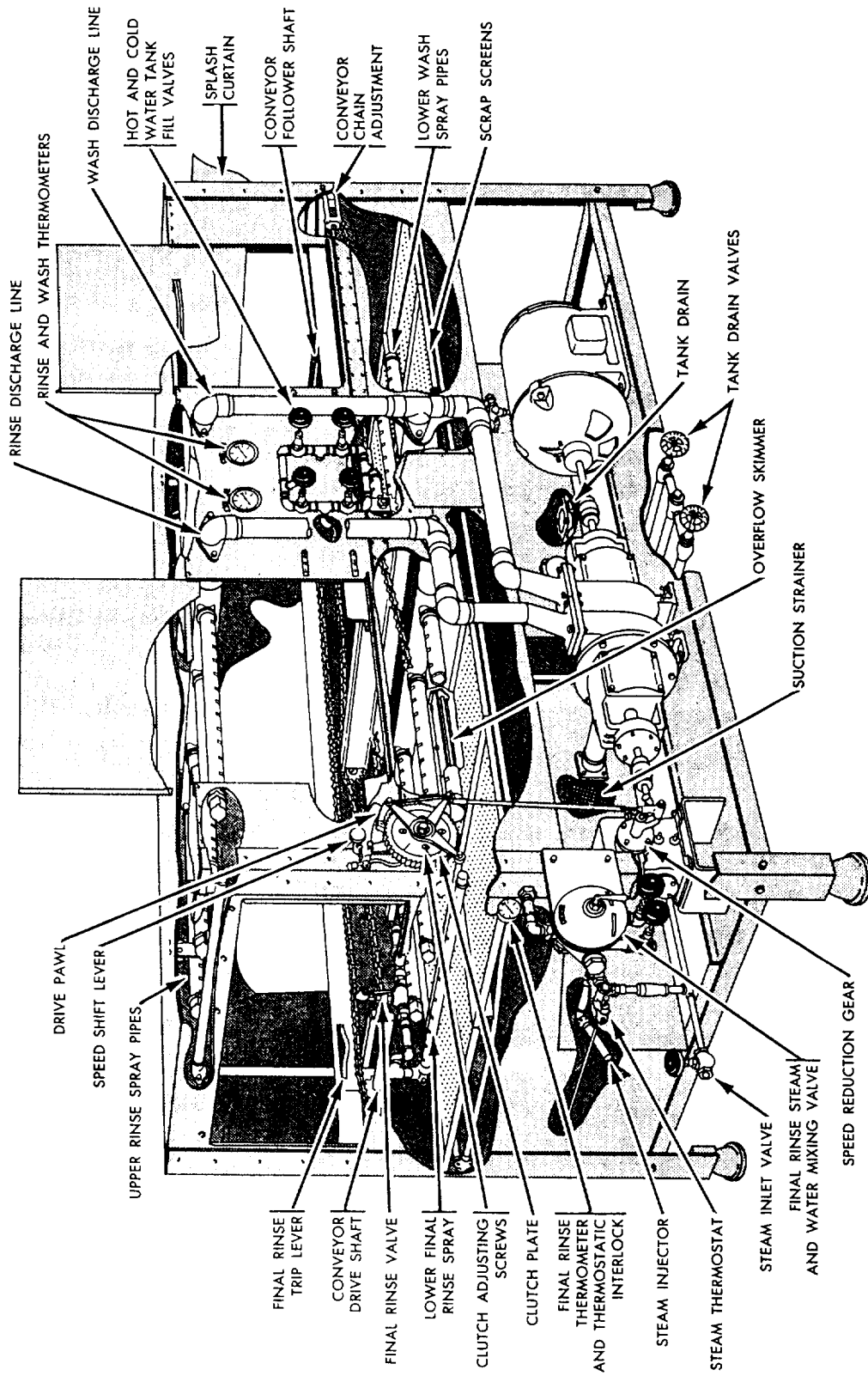

Figure 10-47.—Typical automatic double-tank dishwashing machine.

9G6810-00-264-6722	Orthophosphoric acid 85 percent technical, 7-pound bottle
9Q7930-00-282-9699	Detergent, general- purpose, 1-gallon can
9Q7930-00-985-6911	Detergent, general- purpose, 5-gallon pail

You should know the capacity of the dishwashing machine tanks. Measure (in inches) the inside dimensions of each tank and apply the following formula: length X width X depth (to water line) 231 = capacity in gallons. Steps and key points in descaling the machine:

Steps and key points in descaling the machine.

1. Fill the tanks halfway to the overflow level with hot, clean water. If tanks do not have water level indicators, remove a section of the scrap tray in each tank so that you can see the overflow pipe.
2. Add the required amount of acid and detergent to the water to prepare the cleaning solution. Measure amounts carefully. Use 7 fluid ounces of orthophosphoric acid 85 percent plus 1/2 fluid ounce detergent, general purpose. Use this measure for each gallon capacity of the tank when it is filled to the overflow level.
3. Complete filling the tanks. Fill to the overflow level.
4. Put scrap screens, spray pipes, and splash curtains in place. Remove scale deposits on all attachments.
5. Turn on the machine. Operate the machine at the highest permissible operating temperature for 60 minutes.
6. Turn off and drain the machine. Open the drain valves and allow all the cleaning solution to drain from the tanks.

7. Refill. Use fresh hot water.

8. Turn on the machine. Operate the machine at the highest temperature for 5 minutes.

Repeat steps 7 and 8 several times. Repeat the entire method at such intervals as may be required for operation of the dishwashing machine.

## LAUNDRY EQUIPMENT

Equipment used to clean, dry, and press clothing includes washers, extractors, dryers, dry-cleaning machines, and various types of presses. Most of the maintenance on this equipment is concerned with inspecting and lubricating the various parts.

Most laundry equipment is equipped with a number of safety devices. If disabled, these safety devices can and have caused shipboard fires and damage to equipment, clothing, and personnel. Pay special attention to these safety devices during preventive and corrective maintenance. Pay extra special attention to those devices designed to protect operator personnel.

## SUMMARY

This chapter covered refrigeration equipment, cooling systems, air compressors, purifiers, and lubrication, electrohydraulic drive machinery, and weight-handling equipment. It also covered galley equipment, including steam kettles and dishwashers. Laundry equipment was covered briefly since most of your work is limited to inspection and lubrication.

Think back over these broad areas. If you feel that you do not have a general understanding of your rate as it relates to a specific type of equipment, go back now and review that section.

## CHAPTER 11

# INSTRUMENTS

As a watch stander, you observe or monitor operating equipment and take the necessary steps to detect malfunctions and prevent damage to the equipment. The word *monitor* means to observe, record, or detect an operation or condition using instruments. Measurement, in a very real sense, is the language of engineers. The shipboard engineering plant has many instruments that indicate existing conditions within a piece of machinery or a system. By reading and interpreting the instruments, you can determine whether the machinery or the system is operating within the prescribed range.

Recorded instrument readings are used to make sure the plant is operating properly. They are also used to determine the operating efficiency of the plant. The instruments provide information for hourly, daily, and weekly entries for station operating records and reports. The data entered in the records and reports must be accurate since they are used to determine the condition of the plant over a period of time. Remember, for accurate data to be entered on the records and reports of an engineering plant, you must read the instruments carefully.

In this chapter, we describe various types of indicating instruments that you, as a Fireman, come in contact with while working and standing watch on an engineering plant. Upon completion of this chapter, you should be able to describe the various types of temperature and pressure measuring instruments, indicators, alarms, and the functions for which they are used.

Engineering measuring instruments are typically classified into the following groups:

- Pressure gauges
- Temperature detectors
- Temperature measuring devices
- Electrical indicating instruments
- Liquid-level indicators
- Revolution counters and indicators

- Salinity indicators
- Torque wrenches

We will discuss each of these categories in the following sections.

### PRESSURE GAUGES

The types of pressure gauges used in an engineering plant include Bourdon-tube gauges, bellows, diaphragm gauges, and manometers. Bourdon-tube gauges are generally used for measuring pressures above and below atmospheric pressure. Bellows and diaphragm gauges and manometers are generally used to measure pressures below 15 pounds-per-square-inch gauge (psig). They are also used for *low* vacuum pressure. Low vacuum pressure is slightly less than 14.7 pounds-per-square-inch absolute (psia). Often, pressure measuring instruments have scales calibrated in inches of water (in. H<sub>2</sub>O) to allow greater accuracy.

**NOTE:** On dial pressure gauges, set the adjustable red hand (if installed) at or slightly above the maximum normal operating pressure, or at or slightly below the minimum normal operating pressure, (Refer to *Naval Ships' Technical Manual*, chapter 504, for specific instructions.)

### BOURDON-TUBE GAUGES

The device usually used to indicate temperature changes by its response to volume changes or to pressure changes is called a Bourdon tube. A Bourdon tube is a C-shaped, curved or twisted tube that is open at one end and sealed at the other (fig. 11-1). The open end of the tube is fixed in position, and the sealed end is free to move. The tube is more or less elliptical in cross section; it does not form a true circle. The tube becomes more circular when there is an increase in the volume or the internal pressure of the contained fluid. The spring action of the tube metal opposes this action and tends to coil the tube. Since the open end of the Bourdon tube is rigidly fastened, the sealed end moves as the pressure of the contained fluid changes.

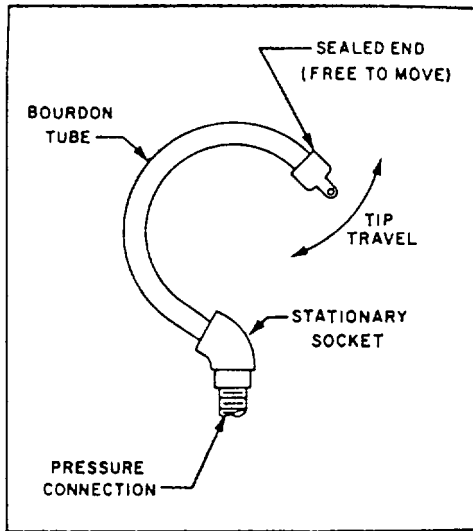

Figure 11-1.—C-shaped Bourdon tube.

There are many types of Bourdon-tube gauges used in the Navy. The most common ones are the simplex, duplex, vacuum, compound, and differential pressure gauges. They operate on the principle that pressure in a curved tube has a tendency to straighten out the tube. This curved tube is made of bronze for pressure under 200 psi and of steel for pressures over 200 psi.

### Simplex Bourdon-tube Gauge

Figure 11-2 shows a simplex Bourdon tube installed in a gauge case. Notice that the Bourdon tube is in the shape of the letter C and is welded or silver-brazed to

the stationary base. The free end of the tube is connected to the indicating mechanism by a linkage assembly. The threaded socket, welded to the stationary base, is the pressure connection. When pressure enters the Bourdon tube, the tube tends to straighten out. The tube movement through linkage causes the pointer to move proportionally to the pressure applied to the tube. The simplex gauge is used for measuring the pressure of steam, air, water, oil, and similar fluids or gases.

### Duplex Bourdon-tube Gauge

The duplex Bourdon-tube gauge (fig. 11-3) has two tubes and two separate gear mechanisms within the same case. As shown in view B, a pointer is connected to the gear mechanism of each tube. Each pointer operates independently. Duplex gauges are normally used to show pressure drops between the inlet and outlet sides of lube oil strainers. If the pressure reading for the inlet side of a strainer is much greater than the pressure reading for the outlet side, you may assume that the strainer is likely to be dirty and is restricting the flow of lube oil through the strainer.

### Bourdon-tube Vacuum Gauge, Compound Gauge, and Differential Pressure Gauge

Bourdon-tube vacuum gauges are marked off in inches of mercury (fig. 11-4). When a gauge is designed to measure both vacuum and pressure, it is called a compound gauge. Compound gauges are marked off both in inches of mercury (in.Hg) and in psig (fig. 11-5).

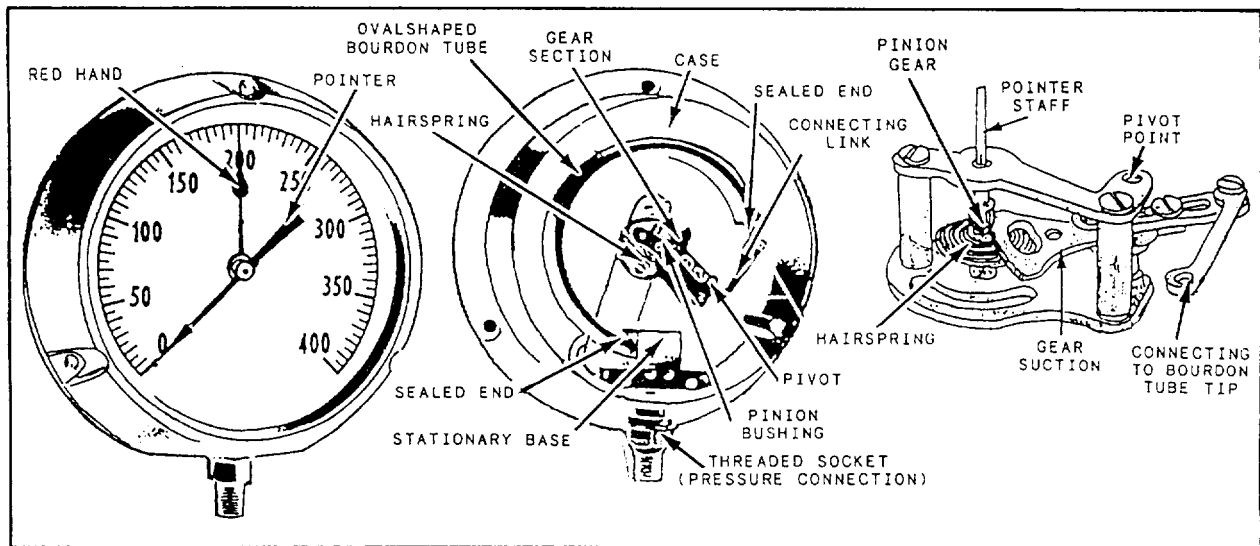

Figure 11-2.—Simplex Bourdon-tube pressure gauge.



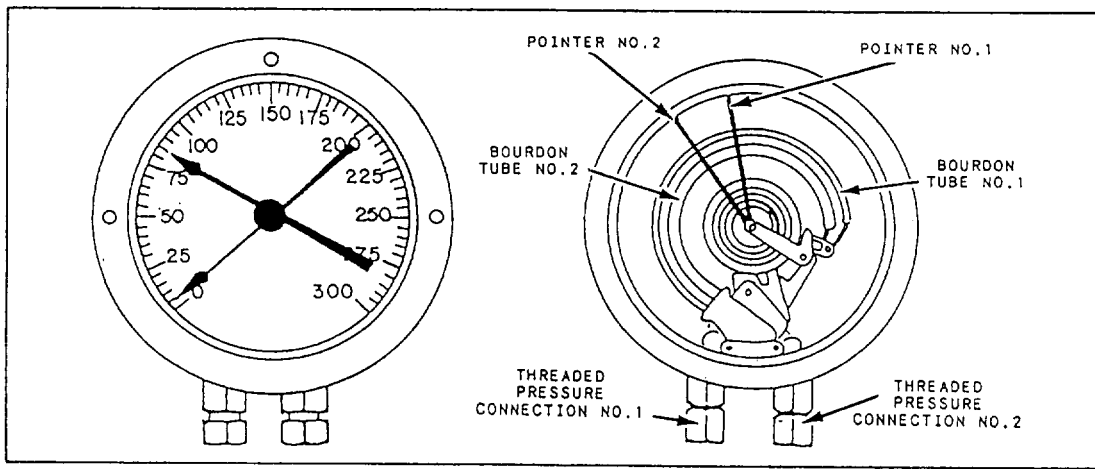

Figure 11-3.—Duplex Bourdon-tube pressure gauge.

Differential pressure may also be measured with Bourdon-tube gauges. One kind of Bourdon-tube differential pressure gauge is shown in figure 11-6. This gauge has two Bourdon tubes, but only one pointer. The Bourdon tubes are connected in such away that they are

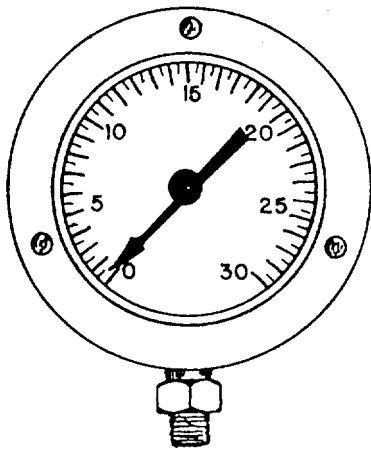

Figure 11-4.—Bourdon-tube vacuum gauge.

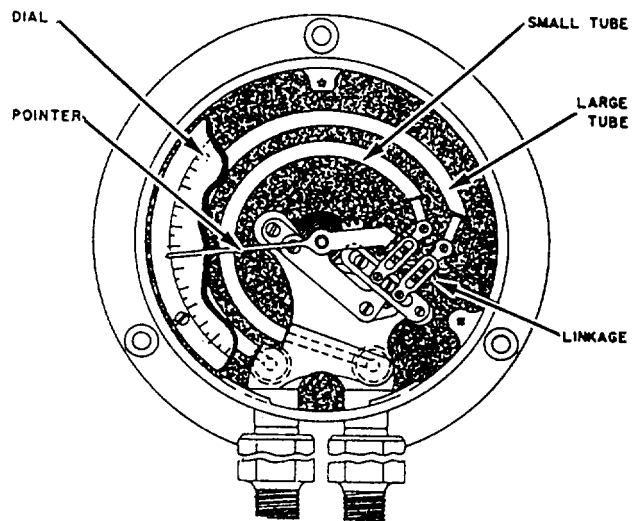
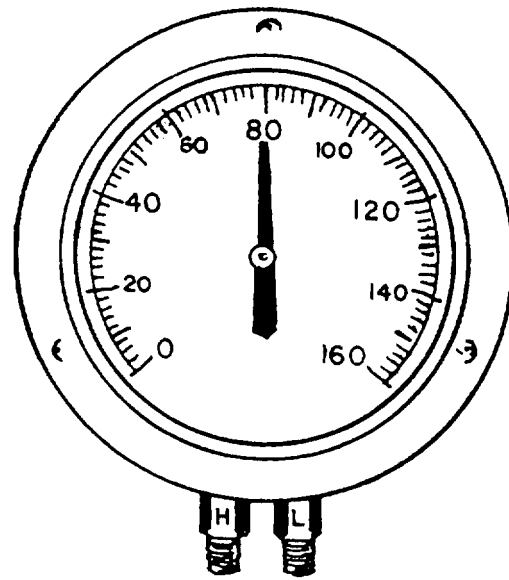

Figure 11-6.—Bourdon-tube differential pressure gauge.

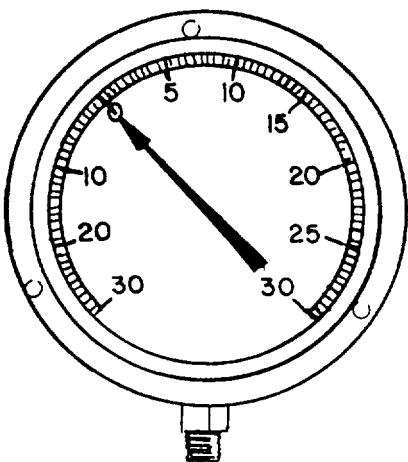

Figure 11-5.—Compound Bourdon-tube gauge.

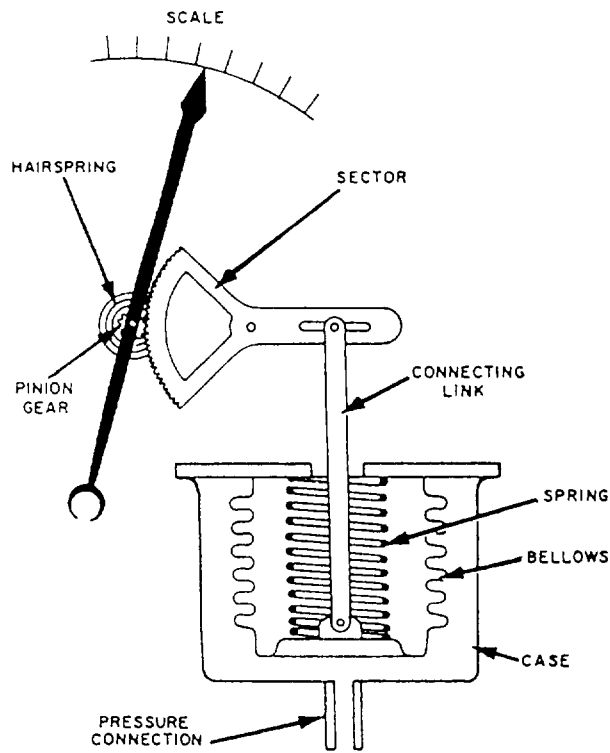

Figure 11-7.—Bellows gauge.

the pressure difference, rather than either of the two actual pressures indicated by the pointer.

## BELLOWS GAUGE

A bellows gauge contains an elastic element that is a convoluted unit that expands and contracts axially with changes in pressure. The pressure to be measured can be applied to the outside or inside of the bellows. However, in practice, most bellows measuring devices have the pressure applied to the outside of the bellows (fig. 11-7). Like Bourdon-tube elements, the elastic elements in bellows gauges are made of brass, phosphor bronze, stainless steel, beryllium-copper, or other metal that is suitable for the intended purpose of the gauge.

Most bellows gauges are spring-loaded; that is, a spring opposes the bellows, thus preventing full expansion of the bellows. Limiting the expansion of the bellows in this way protects the bellows and prolongs its life. In a spring-loaded bellows element, the deflection is the result of the force acting on the bellows and the opposing force of the spring.

Although some bellows instruments can be designed for measuring pressures up to 800 psig, their primary application aboard ship is in the measurement of low pressures or small pressure differentials.

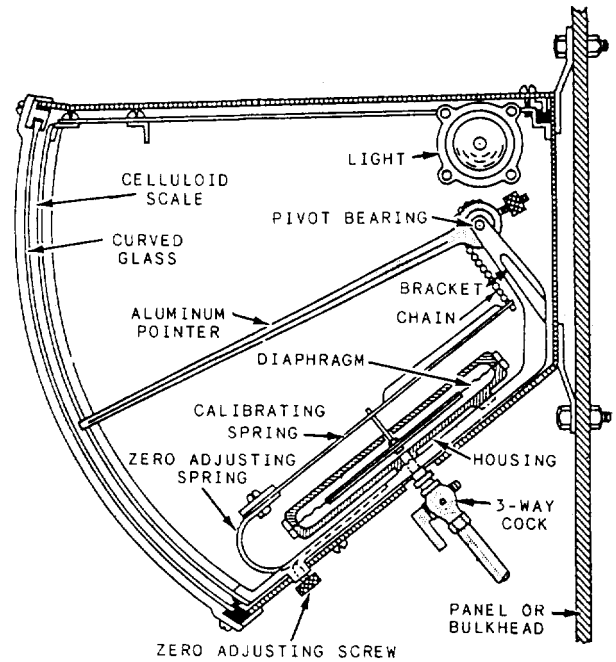

Figure 11-8.—Diaphragm gauge.

Many differential pressure gauges are of the bellows type. In some designs, one pressure is applied to the inside of the bellows, and the other pressure is applied to the outside. In other designs, a differential pressure reading is obtained by opposing two bellows in a single case.

Bellows elements are used in various applications where the pressure-sensitive device must be powerful enough to operate not only the indicating pointer but also some type of recording device.

## DIAPHRAGM GAUGES

Diaphragm gauges are very sensitive and give reliable indication of small differences in pressure. Diaphragm gauges are generally used to measure air pressure in the space between the inner and outer boiler casings.

Figure 11-8 shows the indicating mechanism of a diaphragm gauge. This mechanism consists of a tough, pliable, neoprene rubber membrane connected to a metal spring that is attached by a simple linkage system to the gauge pointer.

One side of the diaphragm is exposed to the pressure being measured, while the other side is exposed to the atmosphere. When pressure is applied to the diaphragm, it moves and, through a linkage system, moves the pointer to a higher reading on the dial. When the

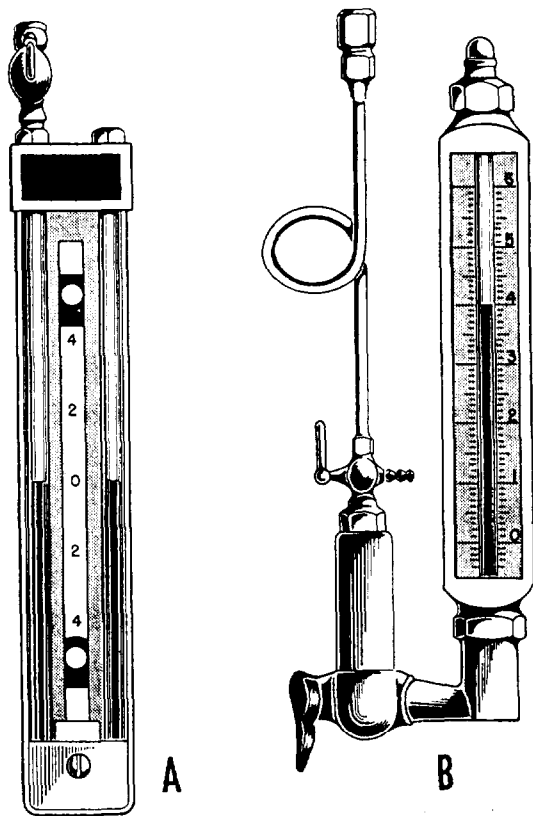

Figure 11-9.—A. Standard U-tube manometer. B. Single-tube manometer.

pressure is lowered, the diaphragm moves the pointer back toward the zero point.

## MANOMETERS

A manometer is perhaps the most accurate, least expensive, and simplest instrument for measuring low pressure or low-pressure differentials. In its simplest form, a manometer consists of either a straight or U-shaped glass tube of uniform diameter, filled with a liquid. The most common liquids used are water and oil. One end of the U-tube is open to the atmosphere, and the other end is connected to the pressure to be measured (fig. 11-9). The liquid reacts to the amount of pressure exerted on it and moves up or down within the tube. The amount of pressure is determined by matching the liquid level against a scale within the manometer.

## TEMPERATURE MEASURING DEVICES

Temperature is one of the basic engineering variables. Therefore, temperature measurement is essential to the proper operation of a shipboard engineering plant. As a watch stander, you will use both mechanical and electrical instruments to monitor

temperature levels. You will frequently be called on to measure the temperature of steam, water, fuel, lubricating oil, and other vital fluids. In many cases, you will enter the results of measurements in engineering logs and records.

## THERMOMETERS (MECHANICAL)

Mechanical devices used to measure temperature are classified in various ways. In this section, we will discuss only the expansion thermometer types. Expansion thermometers operate on the principle that the expansion of solids, liquids, and gases has a known relationship to temperature change. The following types of expansion thermometers are discussed in this section:

- Liquid-in-glass thermometers
- Bimetallic expansion thermometers
- Filled-system thermometers

### Liquid-in-Glass Thermometers

Liquid-in-glass thermometers are the oldest, simplest, and most widely used devices for measuring temperature. A liquid-in-glass thermometer (fig. 11-10)

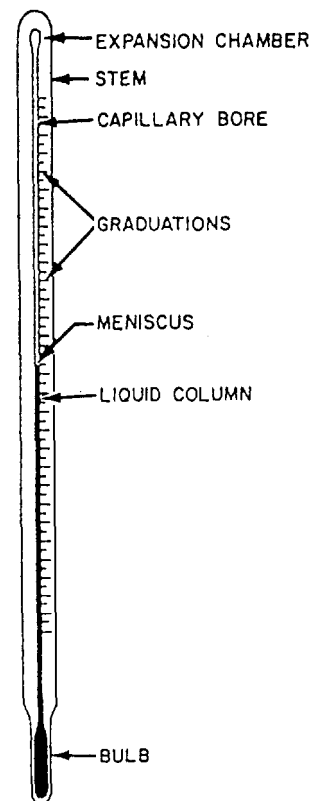

Figure 11-10.—Liquid-in-glass thermometer.

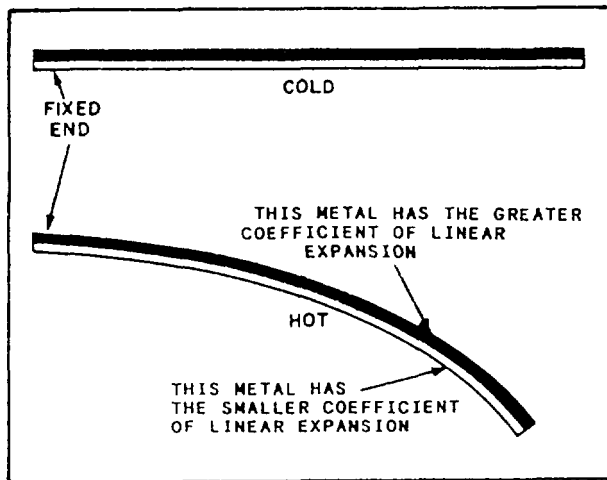

Figure 11-11.—Effect of unequal expansion of a bimetallic strip.

has a bulb and a very fine-bore capillary tube. The tube contains alcohol or some other liquid that uniformly expands or contracts as the temperature rises or falls. The selection of liquid is based on the temperature range for which the thermometer is to be used.

Almost all liquid-in-glass thermometers are sealed so atmospheric pressure does not affect the reading. The space above the liquid in this type of thermometer may be a vacuum, or this space maybe filled with an inert gas, such as nitrogen, argon, or carbon dioxide.

The capillary bore may be round or elliptical. In either case, it is very small; therefore, a relatively small expansion or contraction of the liquid causes a relatively large change in the position of the liquid in the capillary tube. Although the capillary bore has a very small diameter, the walls of the capillary tube are quite thick. Most liquid-in-glass thermometers have an expansion chamber at the top of the bore to provide a margin of safety for the instrument if it should accidentally overheat.

Liquid-in-glass thermometers may have graduations etched directly on the glass stem or placed on a separate strip of material located behind the stem. Many thermometers used in shipboard engineering plants have the graduations marked on a separate strip because this type is generally easier to read.

You will find liquid-in-glass thermometers in use in the oil and water test lab for analytical tests on fuel, oil, and water.

## Bimetallic Expansion Thermometers

Bimetallic expansion thermometers make use of different metals having different coefficients of linear expansion. The essential element in a bimetallic expansion thermometer is a bimetallic strip consisting of two layers of different metals fused together. When such a strip is subjected to temperature changes, one layer expands or contracts more than the other, thus tending to change the curvature of the strip.

Figure 11-11 shows the basic principle of a bimetallic expansion thermometer. One end of a straight bimetallic strip is fixed in place. As the strip is heated, the other end tends to curve away from the side that has the greater coefficient of linear expansion.

When used in thermometers, the bimetallic strip is normally wound into a flat spiral (fig. 11-12), a single helix, or a multiple helix. The end of the strip that is not fixed in position is fastened to the end of a pointer that moves over a circular scale. Bimetallic thermometers are easily adapted for use as recording thermometers; a pen is attached to the pointer and positioned so that it marks on a revolving chart.

## Filled-System Thermometers

Generally, filled-system thermometers are used in locations where the indicating part of the instrument must be placed some distance away from the point where the temperature is to be measured. For this reason, they are often called distant-reading thermometers. However, this is not true for filled-system thermometers. In some designs, the capillary tubing is very short or nonexistent. Generally, however, filled-system thermometers are distant-reading thermometers. Some distant-reading thermometers have capillaries as long as 125 feet.

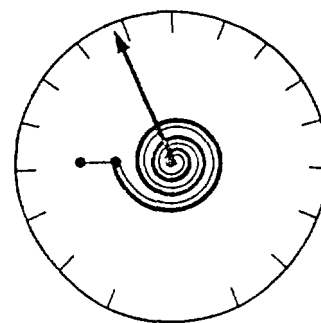

Figure 11-12.—Bimetallic thermometer (flat, spiral strip).

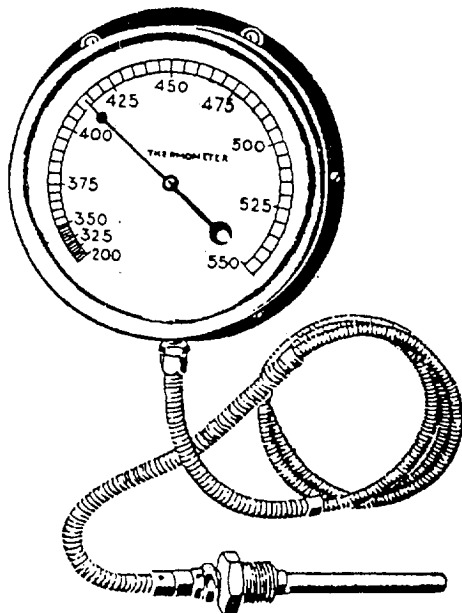

Figure 11-13.—Distant-reading, Bourdon-tube thermometer.

There are two basic types of filled-system thermometers. One type has a Bourdon tube that responds primarily to changes in the volume of the filling fluid. The other type has a Bourdon tube that responds primarily to changes in the pressure of the filling fluid.

A distant-reading thermometer (fig. 11-13) consists of a hollow metal sensing bulb at one end of a small-bore capillary tube. The tube is connected to a Bourdon tube or other device that responds to volume changes or

pressure changes. The system is partially or completely filled with a fluid that expands when heated and contracts when cooled. The fluid may be a gas, an organic liquid, or a combination of liquid and vapor.

## PYROMETERS

Pyrometers are used to measure temperature through a wide range, generally between 300°F and 3,000°F. Aboard ship, pyrometers are used to measure temperatures in heat treatment furnaces, the exhaust temperatures of diesel engines, and other similar purposes.

The pyrometer consists of a thermocouple and a meter (fig. 11-14). The thermocouple is made of two dissimilar metals joined together at one end. It produces an electric current when heat is applied at its joined end. The meter, calibrated in degrees, indicates the temperature at the thermocouple.

## ELECTRICAL TEMPERATURE MEASURING DEVICES

On newer propulsion plants, you will monitor temperature readings at remote locations. Expansion thermometers provide indications at the machinery locations or on gauge panels in the immediate thermometer area. To provide remote indications at a central location, electrical measuring devices along with signal conditioners are used. The devices discussed in this section include the resistance temperature detectors (RTDs), resistance temperature elements (RTEs), and

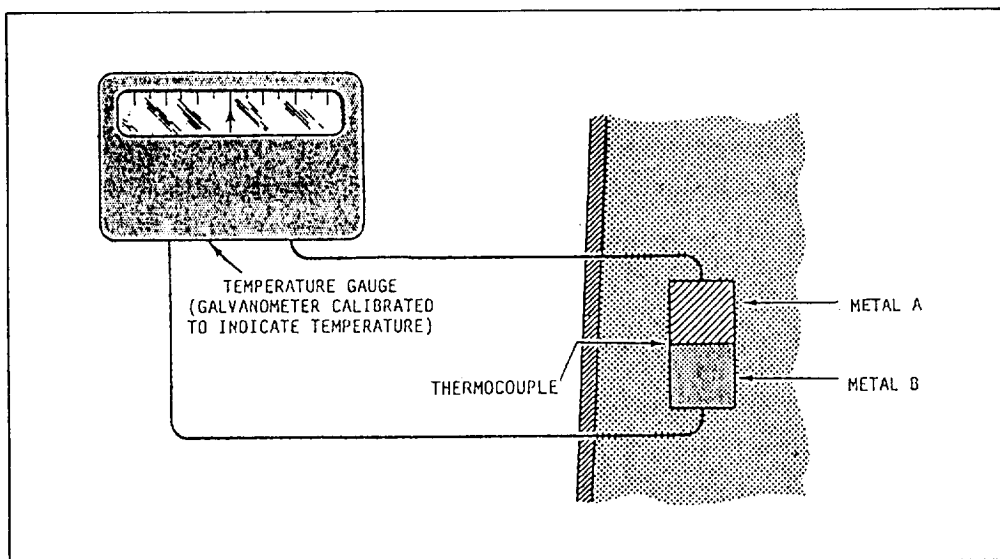

Figure 11-14.—Diagram arrangement of a thermocouple.

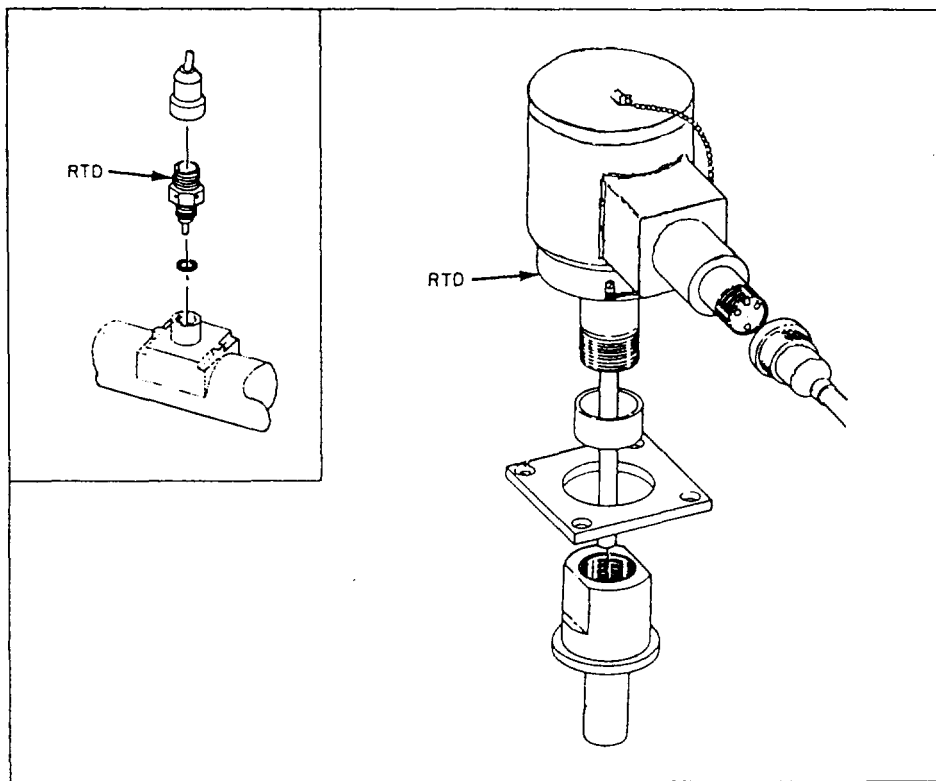

Figure 11-15.—Two typical types of RTDs.

thermocouples. These devices sense variable temperatures at a given point in the system and transmit the signals to a remotely located indicator.

### Resistance Temperature Detectors

The RTDs operate on the principle that electrical resistance changes in a predictable manner with changes in temperature. The elements of RTDs are made of nickel, copper, or platinum. Nickel and copper are used to measure temperatures below 600°F. Platinum elements are used to measure temperatures above 600°F. Figure 11-15 shows two typical types of RTDs.

Like bimetallic thermometers, RTDs are usually mounted in thermowells. Thermowells protect the sensors from physical damage by keeping them isolated from the medium being measured. This arrangement also lets you change the RTD without securing the system in which it is mounted. This makes your maintenance job easier.

As temperature increases around an RTD, the corresponding resistance also increases proportionally. The temperature applied to an RTD, if known, gives you a known resistance value. You can find these resistance values listed in tables in the manufacturers' technical

manuals. Normally, only a few resistance values are given.

To test an RTD, you need to heat it to a specific temperature. At this temperature, the resistance of the RTD should be at the resistance shown in the manufacturer's table. The most common method of heating an RTD is to use a pan of hot water and a calibrated thermometer. Some newer ships and repair activities test RTDs using a thermobulb tester. This method is more accurate and easier to use. For specific instructions, refer to the manufacturers' technical manuals supplied with the equipment.

The most common fault you will find with an RTD is either a short circuit or an open circuit. You can quickly diagnose these faults by using digital display readings or data log printouts. By observing the reading or the printout, you may find that the indication is either zero or a very low value. A malfunction of this type means a short circuit exists in either the RTD or its associated wiring. A very high reading, such as 300°F on a 0°F to 300°F RTD, could indicate an open circuit. You should compare these readings to local thermometers. This precaution allows you to ensure that no abnormal conditions exist within the equipment that the RTD serves.

If an RTD is faulty, you should replace it. Internal repairs cannot be made at the shipboard level. Until you can replace the faulty RTD, inform the watch standers that the RTD is unreliable. The engine-room watch standers should take local readings periodically to make sure the equipment is operating normally.

### Resistance Temperature Elements

The RTEs are the most common type of temperature sensor found in gas turbine propulsion plants. The RTEs operate on the same principle as the RTDs. As the temperature of the sensor increases, the resistance of the RTE increases proportionally. All RTEs that you encounter have a platinum element. They have an electrical resistance of 100 ohms at a temperature of 32°F. Four different temperature ranges of RTEs are commonly used, and you will find that the probe sizes vary. The four temperature ranges and their corresponding probe sizes are as follows:

TEMPERATURE RANGE (Degree Fahrenheit)	RTE PROBE LENGTH (Inches)
-20 to +150	6
0 to +400	2, 4, and 10
0 to +1,000	2
-60 to +500	6

You may find some RTEs connected to remote mounted signal conditioning modules. These modules convert the ohmic value of the RTE to an output range of 4 to 20 mA dc. However, most RTEs read their value directly into the propulsion electronics as an ohmic value.

The RTEs with temperature ranges from 0°F to +400°F and from -60° to +500°F are commonly mounted in thermowells. Since you can change an RTE without securing the equipment it serves, maintenance is simplified.

### ELECTRICAL INDICATING INSTRUMENTS

Electrical indicating instruments (meters) are used to display information that is measured by some type of electrical sensor. Although meters display units such as pressure or temperature, the meters on the control console are, in fact, dc voltmeters. The signal being sensed is conditioned by a signal conditioner. This is

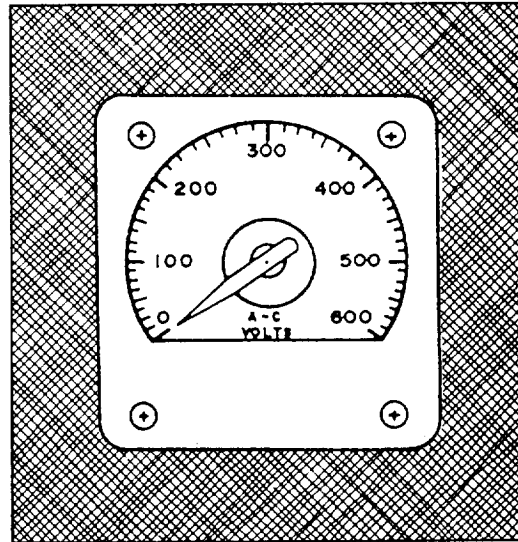

Figure 11-16.—An ac voltmeter.

then converted to 0 to 10 volts dc, which is proportional to the parameters being sensed.

Electrical values, such as power and current, are measured and displayed at ship's service switchboards. Normally, shipboard repair is not done on switchboard meters. If you suspect the switchboard meters are out of calibration or broken, you should have them sent to a repair facility. You can find more information on the theory of operation of these meters in the Navy Electricity and Electronics Training Series (NEETS), Module 3, *Introduction to Circuit Protection, Control, and Measurement*, NAVEDTRA 172-03-00-79.

### VOLTMETERS

Both dc and ac voltmeters determine voltage the same way. They both measure the current that the voltage is able to force through a high resistance. This resistance is connected in series with the indicating mechanism or element. Voltmeters installed in switchboards and control consoles (fig. 11-16) all have a fixed resistance value. Portable voltmeters, used as test equipment, usually have a variable resistance.

For both installed and portable voltmeters, resistances are calibrated to the different ranges that the meters will display. The normal range for the switchboard and electric plant meters is 0 to 600 volts.

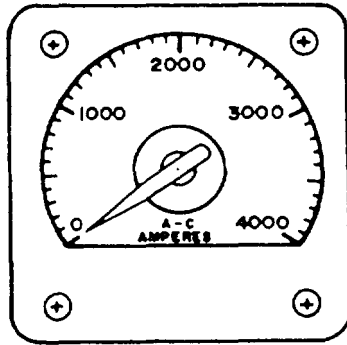

Figure 11-17.—An ac ammeter.

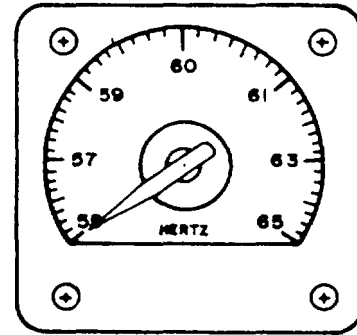

Figure 11-18.—Frequency meter.

## AMMETERS

Ammeters are used to measure the amount of current passing through a conductor (fig. 11-17). Different types of ammeters are used to measure either ac or dc. Ammeters that are designed specifically to indicate ac will also measure dc, but with a lower degree of accuracy.

Ammeters must be connected in series with the circuit to be measured. For this reason, installed ammeters are constructed so that they do not handle the current that passes through the conductor being measured. Since ammeters cannot handle the high switchboard current, the switchboard ammeters operate through current transformers. This arrangement isolates the instruments from the line potential. In its secondary, the current transformer produces a definite fraction of the primary current. This arrangement makes it possible for you to measure large amounts of current with a small ammeter.

### CAUTION

The secondary of a current transformer contains a dangerous voltage. Never work around or on current transformers without taking proper safety precautions.

## FREQUENCY METERS

Frequency meters (fig. 11-18) measure cycles per rate of ac. The range of frequency meters found on gas turbine ships is between 55 hertz (Hz) and 65 Hz. Frequency of the ac used on ships rarely varies below 57 Hz and seldom exceeds 62 Hz. A frequency meter may have a transducer that converts the input frequency to an equivalent dc output. The transducer is a static device that has two separately tuned series-resonant

circuits, which feed a full-wave bridge rectifier. A change in frequency causes a change in the balance of the bridge. This causes a change in the dc output voltage.

## KILOWATT METERS

Power is measured by computing values of current, voltage, and the power factor. The kilowatt meters (fig. 11-19) used on ships automatically take these values into account when they are measuring kilowatts (kW) produced by a generator. Kilowatt meters are connected to both current and potential transformers so they can measure line current and voltage. Since each type of generator is rated differently, the scale is different on each class of ship.

The amount of power produced by a generator is measured in kilowatts. Therefore, when balancing the electrical load on two or more generators, you should make sure the kW is matched. Loss of the kW load is the first indication of a failing generator. For example, if two generators are in parallel, and one of the two units is failing, you should compare the Kw reading. Normally, the generator with the lowest kW would be

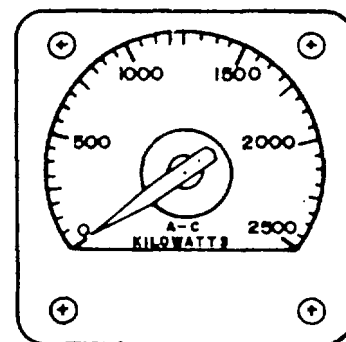

Figure 11-19.—Kilowatt meter.



the failing unit. There is one case, however, where this is not true. During an overspeed condition, both units increase in frequency, but the failing unit is the one with the higher load.

### SYNCHROSCOPES

Before connecting a three-phase generator to bus bars already connected to one or more generators, you must make sure that certain conditions prevail. A synchroscope is the device you use to find out if the following required conditions have been met:

1. Phase sequence for the both generator and bus bars must be the same.
2. The generator and the bus-bar voltages must be the same.
3. The generator and bus-bar frequency must be the same.
4. The generator frequency must be practically constant for an appreciable period of time.
5. The generator and bus-bar voltages must be in phase. They must reach their maximum voltages at the same time; therefore, when connected, they will oppose excessive circulation of current between the two machines.

Figure 11-20 shows a synchroscope. It is basically a power factor meter connection to measure the phase relationship between the generator and bus-bar voltages. The moving element is free to rotate continuously. When the two frequencies are exactly the same, the moving element holds a fixed position. This shows the constant phase relationship between the generator and bus-bar voltages. When the frequency is slightly different, the phase relationship is always changing. When this happens, the moving element of the synchroscope rotates constantly. The speed of rotation is equal to the difference infrequency; the direction shows whether the generator is fast or slow. The generator is placed on line when the pointer slowly approaches a mark. This mark shows that the generator and bus-bar voltages are in phase.

### PHASE-SEQUENCE INDICATORS

A phase-sequence indicator (fig. 11-21) is used to determine the sequence in which the currents of a three-phase system reach their maximum values.

Ships have phase-sequence indicators installed in switchboards that may be connected to shore power. These instruments indicate whether shore power is in

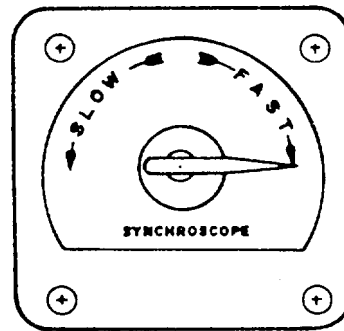

Figure 11-20.—Synchroscope.

the correct phase sequence with the ship **before** shipboard equipment is connected to shore power. Three-phase motors, when connected to incorrect phase-sequence power, rotate in the opposite direction.

The phase-sequence indicator has three neon lamps that light when all three phases are energized. A meter connected to a network of resistors and condensers shows correct or incorrect sequence on a marked scale.

### LIQUID-LEVEL INDICATORS

As a watch stander, you monitor systems and tanks for liquid levels. Sometimes, you are only required to know if a level exceeds or falls below a certain preset parameter. At other times, you need to know the exact level. If only a predetermined limit is needed, you can use a float switch. When the set point is reached the float switch will make contact and sound an alarm. If you need to know a specific level, you must use a variable sensing device. The sensor used to indicate a tank level is commonly called a tank level indicator (TLI). This sensor tells you the exact amount of liquid in a tank. In the following paragraphs, we will describe the operation

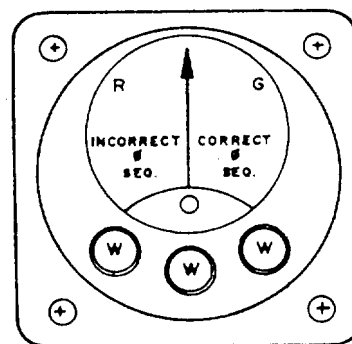

Figure 11-21.—A phase-sequence indicator.

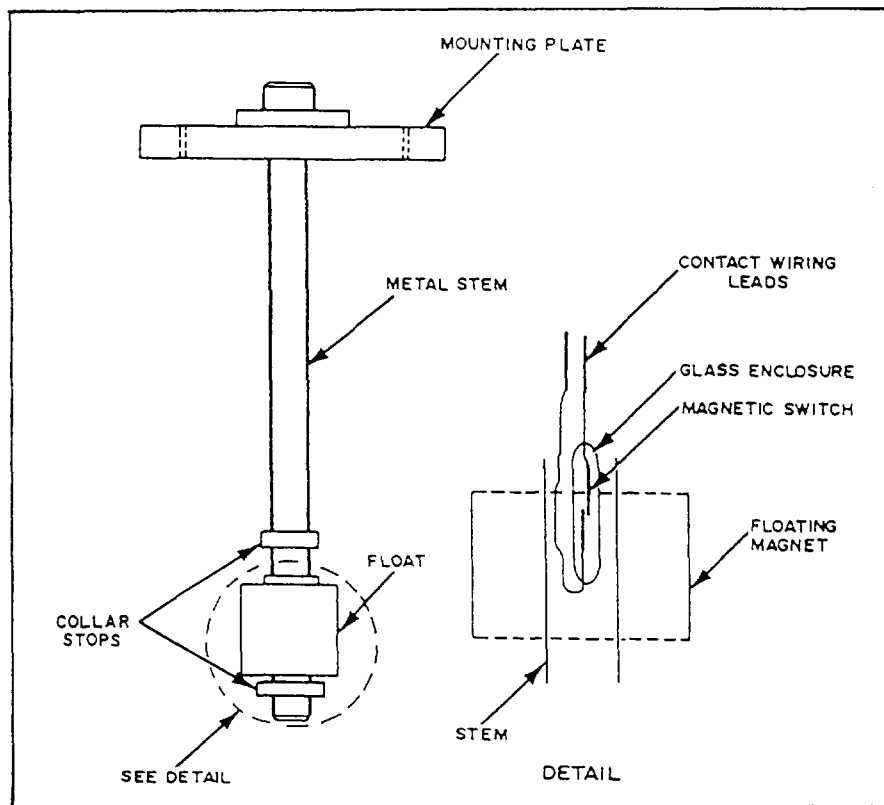

Figure 11-22.—Magnetic float switch.

of each of these sensors and their applications. Refer to the manufacturers' technical manuals for more information on the procedures you should use to adjust each type of device.

### TANK LEVEL INDICATORS

Many tank levels are monitored to provide the exact liquid level contained. For example, fuel tanks are monitored to make sure they do not overflow. They are also monitored to let the engineer officer know the amount of fuel aboard ship. The sensors used to monitor these levels are TLIs. Each of the level-monitored tanks contains a level transmitter. A typical transmitter section contains a voltage divider resistor network that extends the length of the section. Magnetic reed switches are tapped at 1-inch intervals along the resistor network. The reed switches are sequentially connected through series resistors to a common conductor. This network is enclosed in a stem that is mounted vertically in the tank. A float containing bar magnets rides up and down the stem as the liquid level changes.

In many tanks, you may have to use more than one transmitter section to measure the full range. The physical arrangement of some tanks makes this

necessary. When multiple sections are used, they are electrically connected as one continuous divider network.

Two types of floats are used. In noncompensated tanks, the float is designed to float at the surface of the fuel or JP-5. For seawater-compensated tanks, the float is designed to stay at the seawater/fuel interface.

### CONTACT LEVEL SENSORS

Many times, you do not have to know the exact level of a tank until it reaches a preset level. When this type of indication is needed, you can use a contact or float switch. Two types of float level switches are used on gas turbine ships.

One type of float level switch is the lever-activated switch, which is activated by a horizontal lever attached to a float. The float on this switch is located inside the tank. When the liquid level reaches a preset point, the lever activates the switch.

The other type of level switch has a magnet-equipped float that slides on a vertical stem. The stem contains a hermetically sealed, reed switch. The float moves up and down the stem with the liquid level.

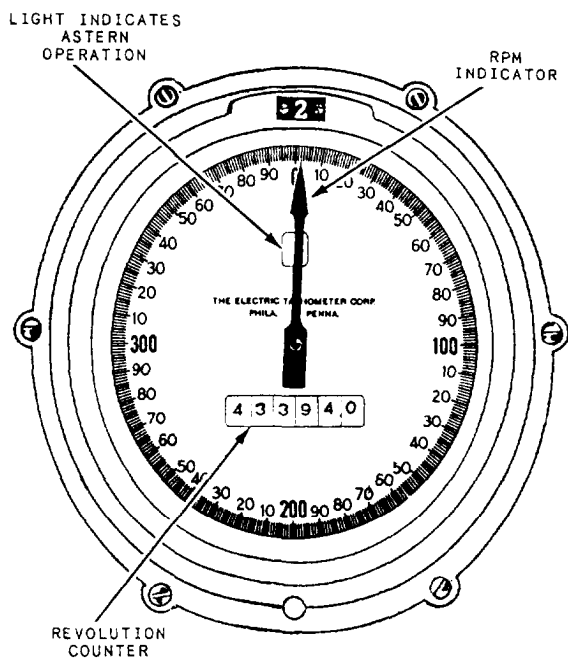

Figure 11-23.—Revolution counter.

It magnetically opens or closes the reed switch as the float passes over it. Figure 11-22 shows the construction of the magnetically operated float switch. Magnetic float switches may be constructed with more than one float on a stem. Magnetic float switches can be installed to detect multiple levels in the same tank; and this type of switch can activate a high- and low-level alarm.

### REVOLUTION COUNTERS AND INDICATORS

Measurements of rotational speed are necessary for the proper operation of pumps, forced-draft blowers, main engines, and other components of the engineering plants. Various types of instruments are used to measure equipment revolutions per minute (rpm) and count the number of revolutions a shaft makes.

### PROPELLER INDICATORS

Propeller indicators are mounted on the throttle board. They indicate the speed and direction of rotation of the propulsion shaft or shafts. They also record the number of revolutions the propulsion shaft has made. The speed of rotation is important because it is related to the ship's speed. The total number of revolutions is used to determine the total distance traveled by the ship. A typical revolution counter is shown in figure 11-23.

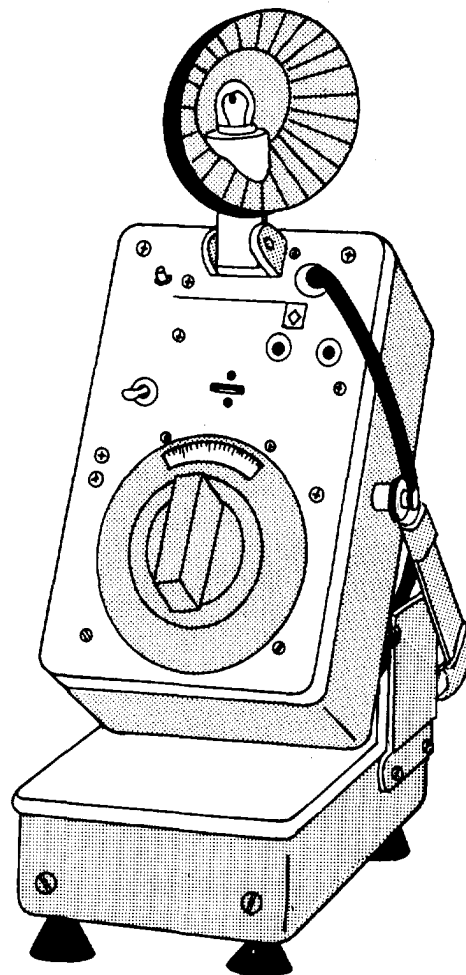

Figure 11-24.—stroboscope tachometer.

### OTHER REVOLUTION INDICATORS

Equipment speed is determined by either permanently installed mechanical or electrical tachometers or by portable tachometers. Portable tachometers are hand-held, mechanical types. They require access to the end of the rotating machinery shaft.

Another type of tachometer is the stroboscope tachometer (fig. 11-24). This device allows rotating machinery to be viewed intermittently, under flashing light, so that the rotation appears to stop.

### WARNING

If you use a stroboscopic tachometer, NEVER reach into the rotating machinery. Although the machinery appears to be stopped, it is still rotating.

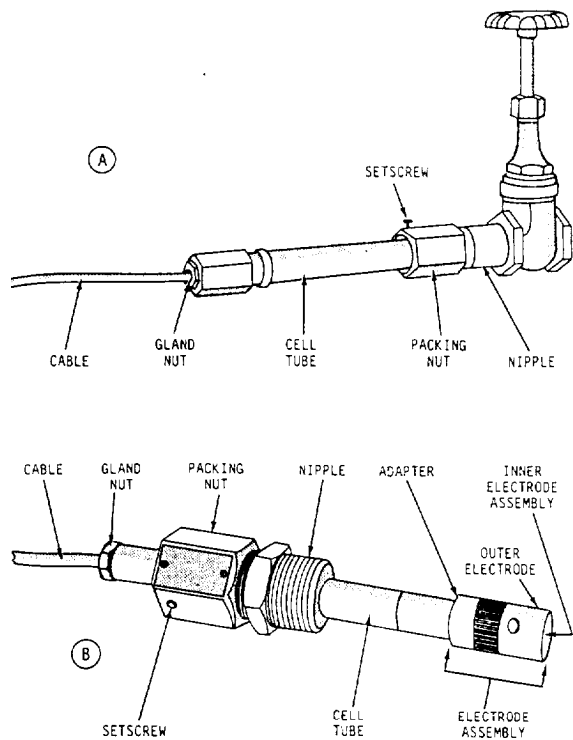

Figure 11-25.—Salinity cell and valve assembly.

Because the light is intermittent, the eye receives a series of views rather than one continuous view. To measure the speed of a machine, find the rate of intermittent light at which the machinery **appears** to be stopped. Then, you either read the speed of rotation directly from the stroboscope's indicator or convert the strobe's flash rate to rpm.

### SALINITY INDICATORS

Electrical salinity indicating cells (fig. 11-25) are installed throughout distilling plants to maintain a constant check on the distilled water. An electrical salinity indicator consists of a number of salinity cells in various locations in the plant. For example, an electrical salinity indicator might consist of salinity cells placed in the evaporators, the condensate pump discharge, and the air-ejector condenser drain. These salinity cells are all connected to a salinity indicator panel.

Since the electrical resistance of a solution varies according to the amount of ionized salts in the solution, it is possible to measure salinity by measuring the electrical resistance. The salinity indicator panel is equipped with a meter calibrated to read directly, either in equivalents per million (epm) or grains per gallon (gpg).

**NOTE:** Other dissolved solids, in addition to ionized salt, may change the electrical resistance of water. To be safe, always assume that any resistance change is caused by ionized salt.

### TORQUE WRENCHES

At times, you will need to apply a specific force to a nut or bolt head. At these times, you will use a torque wrench. For example, equal force must be applied to all the head bolts of an engine. Otherwise, only one bolt may bear the brunt of the force of internal combustion, ultimately causing engine failure. A torque wrench will allow you to apply the specifically required force.

The three most commonly used torque wrenches are the deflecting beam, the dial-indicating, and the micrometer-setting types (fig. 11-26). When using a deflecting-beam or dial-indicating torque wrench, you visually read the torque on a dial or scale mounted on the handle of the wrench. The micrometer-setting torque wrench, however, indicates the torque value by sound.

To use the micrometer-setting torque wrench, you unlock the grip and adjust the handle to the desired setting on the scale; then, relock the grip. Next, install the required socket or adapter to the square drive of the handle. Place the wrench assembly on the nut or bolt and pull in a clockwise direction, using a steady, smooth motion. (A fast or jerky motion results in an improperly torqued unit.) When the torque applied reaches the required torque value, a signal mechanism automatically issues an audible click; and the handle will release or break, moving freely for a short distance. The release and free travel are easily felt. This feature indicates that the torquing process is complete.

You should use a torque wrench that reads about mid-range for the amount of torque to be applied. Manufacturers' and technical manuals generally specify the amount of torque to be applied. To make sure the correct amount of torque is applied to the fasteners, you must use the torque wrench according to the specific manufacturer's instructions.

### CAUTION

Be sure the torque wrench has been calibrated before you use it.

Remember, the accuracy of torque measuring depends on how the threads are cut and the cleanliness of the threads. Make sure you inspect and clean the threads. If the manufacturer specifies a thread lubricant,

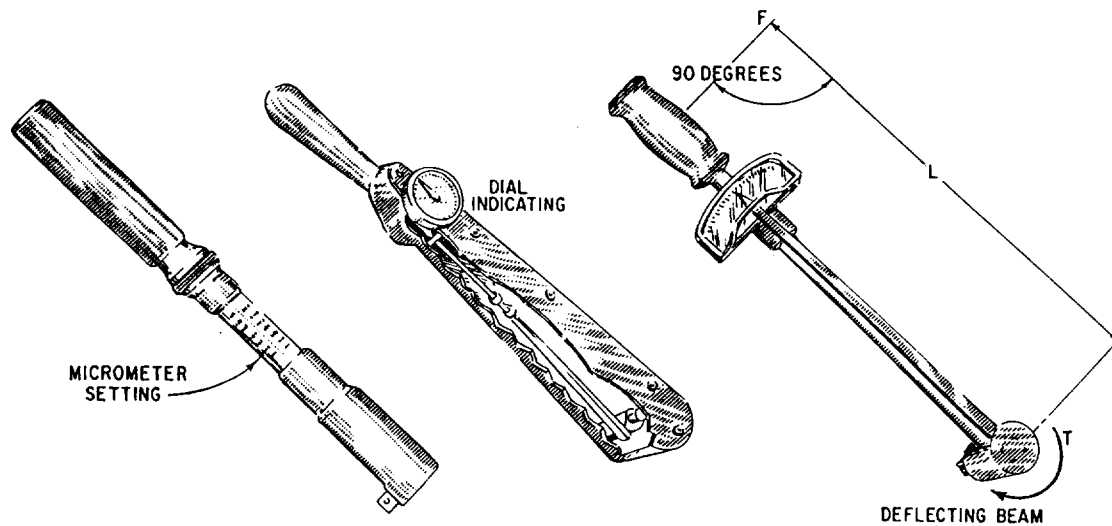

Figure 11-26.—Torque wrenches.

use it. When using deflecting-beam or dial-indicating wrenches, hold the torque at the desired value until the reading is steady.

Torque wrenches are delicate and expensive tools. When using them, always follow these precautions:

- When you use the micrometer-setting type, do not move the setting handle below the lowest torque setting. However, place it at its lowest setting before you return it to storage.
- Do not use the torque wrench to apply greater amounts of torque than its rated capacity.
- Do not use the torque wrench to break loose bolts that have been previously tightened.
- Do not drop the wrench. If a torque wrench is dropped, its accuracy will be affected.
- Do not apply a torque wrench to a nut that has been tightened. Back off the nut one turn with a nontorque wrench and retighten it to the correct torque with the indicating-torque wrench.
- Calibration intervals have been established for all torque tools used in the Navy. When a tool is calibrated by a qualified calibration activity at a shipyard, tender, or repair ship, a label showing

the next calibration due date is attached to the handle. Before you use a torque tool, check this date to make sure the tool is not overdue for calibration.

### SUMMARY

Only a few of the many types of instruments used by Navy personnel have been covered in this chapter. For the operating principle of individual systems, you should consult the specific equipment technical manuals and the NSTM, chapter 504.

Just as we monitor automobile instruments (oil pressure gauge/light, fuel tank level indicator, water temperature gauge, and so forth) to determine how an automobile is operating, we use instruments to determine how the engineering plant is operating. In addition to the use of visual indicating equipment in an engineering plant, audible alarms warn operating personnel of actions required or of unsafe conditions that are approaching. You may avoid machinery damage, personnel injury, and expensive and time-consuming repairs by taking proper operator action. However, proper operator actions can take place only when the instruments (temperature indicators, pressure gauges, and so forth) are properly calibrated and properly interpreted by operating personnel.



## CHAPTER 12

# SHIPBOARD ELECTRICAL EQUIPMENT

Aboard modern naval ships, most auxiliary machinery and equipment is run by electricity. Regardless of rate or rating, all personnel assigned to a ship will operate some electric devices in the performance of their duties. Electrical equipment is dangerous if handled incorrectly; therefore, you must observe all applicable safety precautions when working with or around electrical equipment.

In this chapter, we will discuss basic concepts of electricity, electrical terms, electrical equipment, and applicable safety precautions. You will find additional information on the basic principles of electricity in the *Navy Electricity and Electronics Training Series* (NEETS), modules 1 and 2, NAVEDTRA 172-01-00-79 and NAVEDTRA 172-02-00-79.

### INTRODUCTION TO ELECTRICITY

Some materials will conduct electricity, and some offer more resistance than others. Metals such as silver, copper, aluminum, and iron offer little resistance and are called *conductors*. In contrast to conductors, some materials such as wood, paper, porcelain, rubber, mica, and plastics offer high resistance to an electric current and are known as *insulators*. Electric circuits throughout the ship are made of copper wires covered with rubber or some other insulator. The wire conductors offer little resistance to the current, while the insulation keeps the current from passing to the steel structure of the ship.

Definite units have been established so we can measure the electrical properties of conductors. Also, there are terms used to describe the characteristics of electric currents. A brief review of these fundamentals is given in the following sections.

### ELECTRIC CURRENT

The flow of current through a wire can be compared to the flow of water through a pipe.

Current is the rate at which electricity flows through a conductor or circuit. The practical unit, called the *ampere*, specifies the rate at which the electric current is flowing. Ampere is a measure of the intensity or the number of electrons passing a point in a circuit each second.

### ELECTROMOTIVE FORCE

Before water will flow through a pipe, there must be water pressure; before an electric current can flow through a circuit, there must be a source of electric pressure. The electric pressure is known as *electromotive force (emf)* or *voltage (E)*. The source of this force may be a generator or a battery.

If you increase the pressure on the electrons in a conductor, a greater current will flow, just as an increased pressure on water in a pipe will increase the flow.

### RESISTANCE

Electrical resistance (R) is that property of an electric circuit that opposes the flow of current. The unit of resistance is known as the *ohm* ( $\Omega$ ).

### WATT

Power (P) is the rate of doing work. In a dc circuit, power is equal to the product of the current times the voltage, or  $P = I \times E$ . The practical unit of power is the watt (W) or kilowatt (kW) (1,000 watts). Power in an ac circuit is computed in a slightly different way. If you are interested in how ac power is computed, see chapter 4 of *Introduction to Alternating Current and Transformers*, NAVEDTRA 172-02-00-85.

### GENERATOR TYPES AND DRIVES

A large amount of electricity is required aboard ship to power machinery that supplies air,

water, food, and other services. Communications between the various parts of a ship also depend on the availability of electric power. The generator is the power source for the ship's electrical system.

A generator operates most efficiently at its full-rated power output, and it is not practical to have one large generator operating constantly at reduced load. Therefore, two or more smaller generators that are operated at high load are installed aboard ship.

Two or more generators are usually installed aboard ship for another reason. If one generator is shut down because of damage or scheduled maintenance, there is still a source of power for lighting until the defective generator has been repaired. In addition, generators are widely spaced in the engineering spaces to decrease the chance that all electrical plants would be disabled by enemy shells.

Most generators used aboard ships are ac generators. However, since some dc generators are still in service, we will briefly discuss dc generators before moving on to ac generators.

## DC GENERATORS AND EXCITERS

A dc generator is a rotating machine that changes mechanical energy to electrical energy. There are two essential parts of a dc generator:

1. The yoke and field windings, which are stationary, and
2. the armature, which rotates.

In the past, ship's service generators produced direct current. At present, practically all ships have 450-volt, 60-hertz (Hz), ac ship's service and emergency generators. The dc generators used in Navy installations for ship's service or for exciters operate at either 120 volts or 240 volts. The power output depends on the size and design of the dc generator. A typical dc generator is shown in figure 12-1.

## AC GENERATORS

AC generators are also called *alternators*. In an ac generator, the field rotates, and the armature is stationary. To avoid confusion, the rotating members of dc generators are called *armatures*; in ac generators, they are called *rotors*.

The general construction of ac generators is somewhat simpler than that of dc generators. An ac generator, like a dc generator, has magnetic fields and an armature. In a small ac generator the armature revolves, the field is stationary, and no commutator is required. In a large ac generator, the field revolves and the armature is wound on the stationary member or stator.

The principal advantages of the revolving-field generators over the revolving-armature generators are as follows:

- The load current from the stator is connected directly to the external circuit without using a commutator.

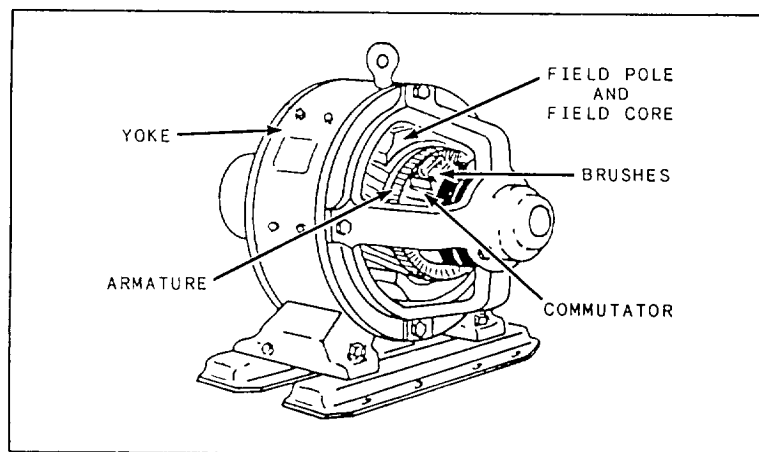
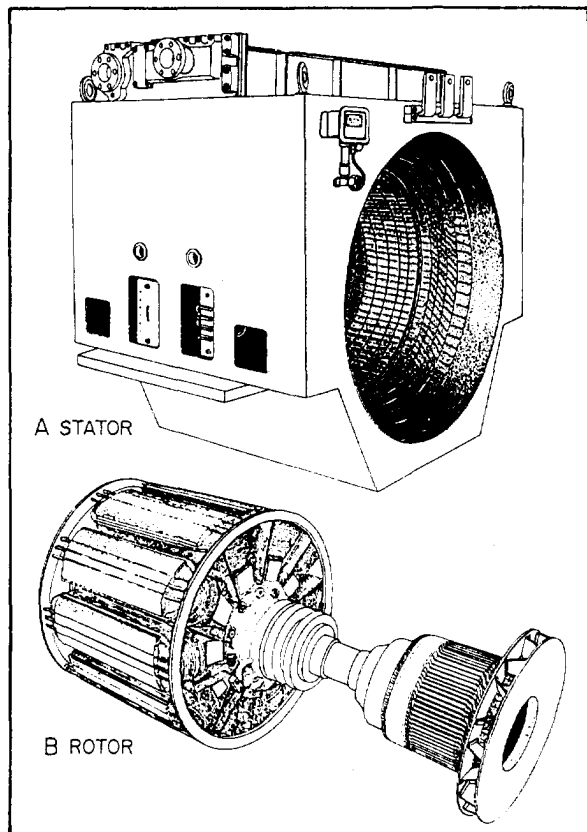

Figure 12-1.—A dc generator.





139.43

Figure 12-2.—Low-speed, engine-driven alternator.

- Only two slip rings are necessary to supply excitation to the revolving field.
- The stator winding is not subjected to mechanical stresses that are due to centrifugal force.

The ac generators (alternators) used by the Navy are divided into two classes: (1) low-speed, engine-driven alternators and (2) high-speed, turbine-driven alternators.

The low-speed, engine driven alternator (fig. 12-2) has a large diameter revolving field, with many poles, and a stationary armature. The stator (view A) contains the armature windings. The rotor (view B) consists of protruding poles on which the dc field windings are mounted.

The high-speed alternator may be either steam or gas-turbine driven. The high-speed, turbine-driven alternator (fig. 12-3) is connected either directly or through gears to a steam turbine. The

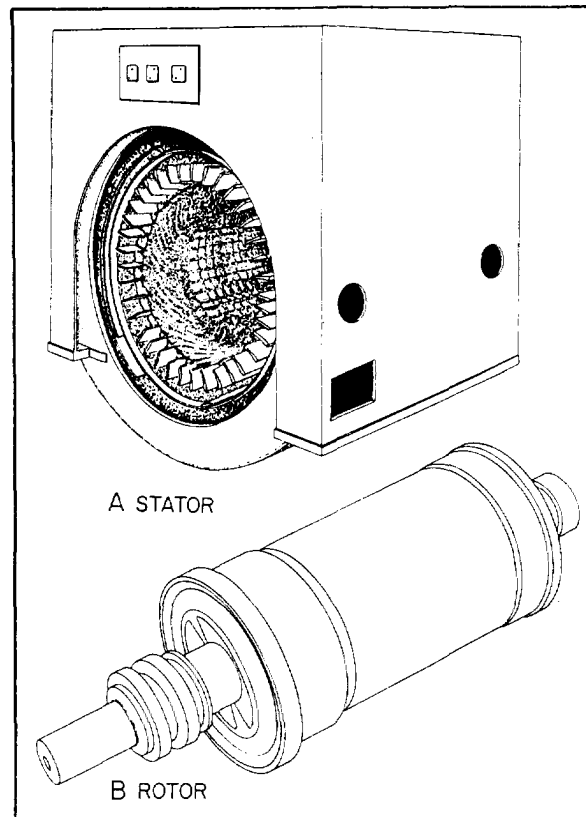

139.44

Figure 12-3.—High-speed, turbine-driven alternator.

enclosed metal structure is part of a forced ventilation system that carries away the heat by circulating air through the stator (view A) and rotor (view B).

### SHIP'S SERVICE TURBINE-DRIVEN GENERATORS

Ship's service generators furnish electricity for the service of the ship. Aboard most steam-driven ships of the Navy, these generators are driven by turbines. Large ships may have as many as six or eight ship's service generators and from one to three emergency diesel-driven alternators.

New cruisers and destroyers have three gas-turbine-driven ship's service generators and smaller diesel-driven emergency generators. These generators are located in three different compartments and separated by at least 15 percent of the length between perpendiculars to make sure they survive.

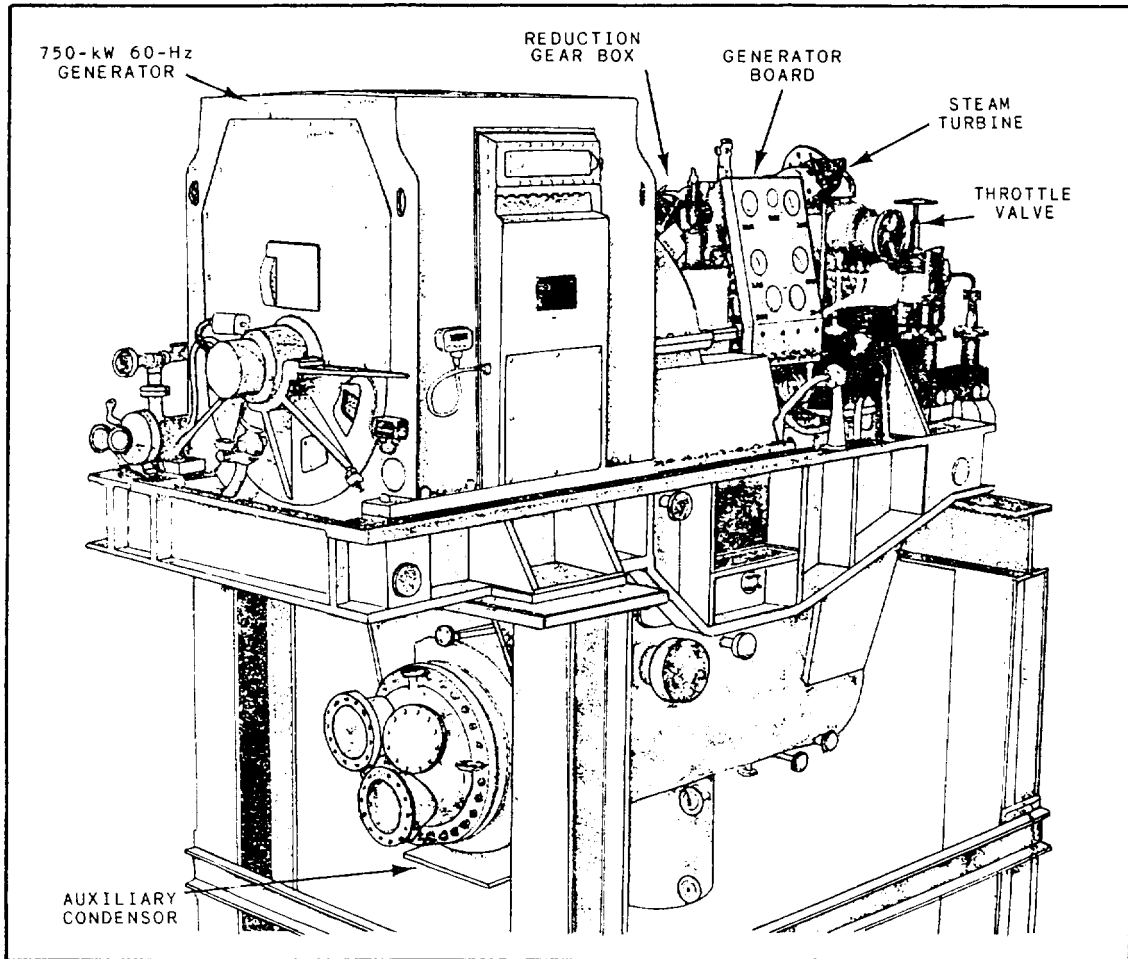

139.57

Figure 12-4.—750-kW turbine generator set.

The type of ship's service generator commonly used aboard ships in the Navy is shown in figure 12-4. Although generator sets (turbogenerators) are built differently, all have the same arrangement of major parts.

Turbines used for driving the ship's service generators differ from other auxiliary turbines; they usually operate on superheated steam. The service generator turbine exhausts to a separate auxiliary condenser that has its own circulating pumps, condensate pumps, and air ejectors. Cooling water for the condenser is provided by the auxiliary circulating pump through separate injection and overboard valves.

Superheated steam is supplied to the ship's service generator turbine from either the main steam line or a special turbogenerator line that leads directly from the boiler. Aboard some ships, the turbine—in the event of condenser

casualty—may be discharged directly to the atmosphere or to the main condenser when the main plant is in operation.

The ship's service generator must supply electricity at a constant voltage and frequency (hertz), which requires the turbine to run at a constant speed even when loads vary. Constant speed is maintained by a speed-regulating governor. The turbine also has overspeed and back-pressure trips, which automatically close the throttle if the turbine exceeds acceptable operating conditions. A manual trip is used to close the throttle quickly if there is damage to the turbine or to the generator. The shaft glands of the ship's service generator turbine are supplied with gland-sealing steam. The system is similar to that used for main propulsion turbines. Other auxiliary turbines in naval use are seldom, if ever, provided with gland-sealing systems.

## DIESEL-DRIVEN GENERATORS

Practically all Navy ships are equipped with diesel-driven emergency generators. Diesel engines are particularly suited for this application because of their quick starting ability. Emergency generators furnish power directly to the radio, radar, gunnery, and vital machinery equipment through an emergency switchboard and automatic bus transfer equipment.

The typical shipboard plant consists of two diesel emergency generators, one forward and one aft, in spaces outside engine rooms and firerooms. Each emergency generator has its own switchboard and switching arrangement. This controls the generator and distributes power to certain vital auxiliaries and a minimum number of lighting fixtures in vital spaces.

The capacity of the emergency units varies with the size of the ship. Regardless of the size of the installation, the principle of operation is the same.

You may obtain detailed information concerning the operation of diesel-driven generators from appropriate manufacturers' technical manuals.

## MOTOR GENERATORS

Aboard Navy ships, certain weapons, interior communications, and other electronics systems

require closely regulated electrical power for proper operation. Special, closely regulated motor generator (MG) sets supply this power (usually 400 Hz). Any given ship has several MGs to provide power to specific loads. These MGs are often of different ratings. The rating of an MG set can be less than 1 kW or as large as 300 kW. MGs can also be used to provide electrical isolation. Isolation is required when certain loads cause distortion of the power and adversely affect the operation of other equipment.

The MG set (fig. 12-5) is generally a two-bearing unit. (Older units often consist of a separate motor and generator connected together and mounted on a bedplate.) The frame is of one-piece construction. The stationary component parts of the motor and generator are press fit into a welded steel frame. The rotating elements are mounted on a single one-piece shaft. The MG is usually deck mounted horizontally on its own integral feet; however, some specially designed, vertically mounted units are also provided. MGs with 100-kW power and larger are usually cooled by a water-air cooler mounted on top of the MG.

Solid-state voltage and, often, frequency regulating systems are provided on MGs. They are mounted either in a control box, which is directly mounted on the MG for forced-air cooling, or in bulkhead-mounted control panels. The voltage

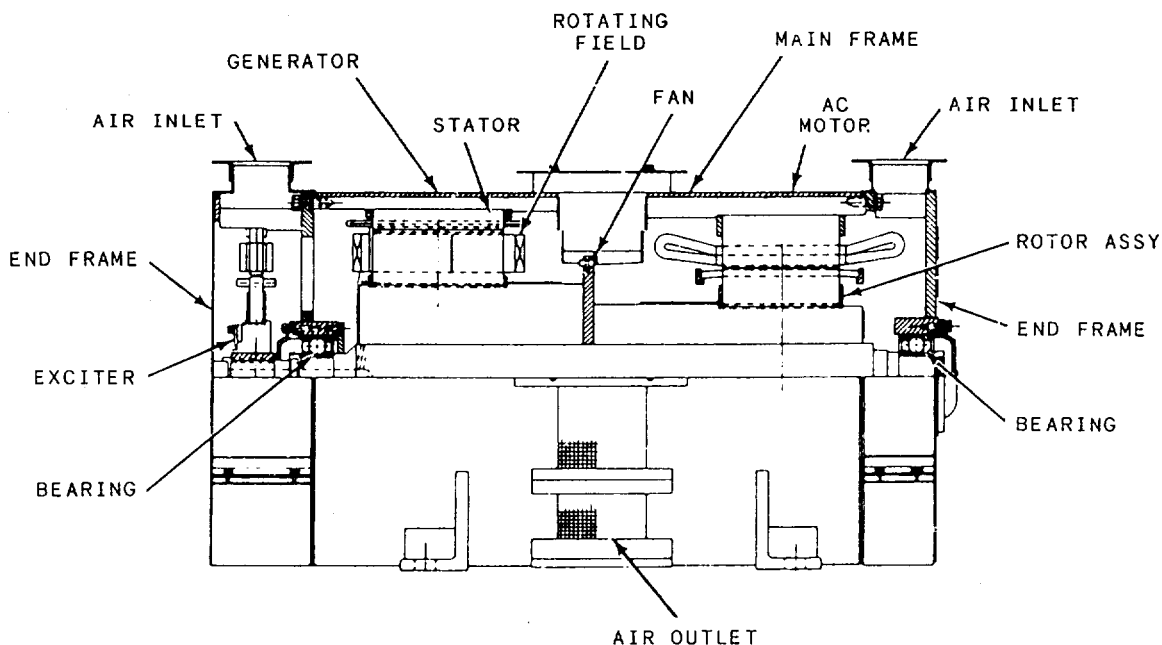
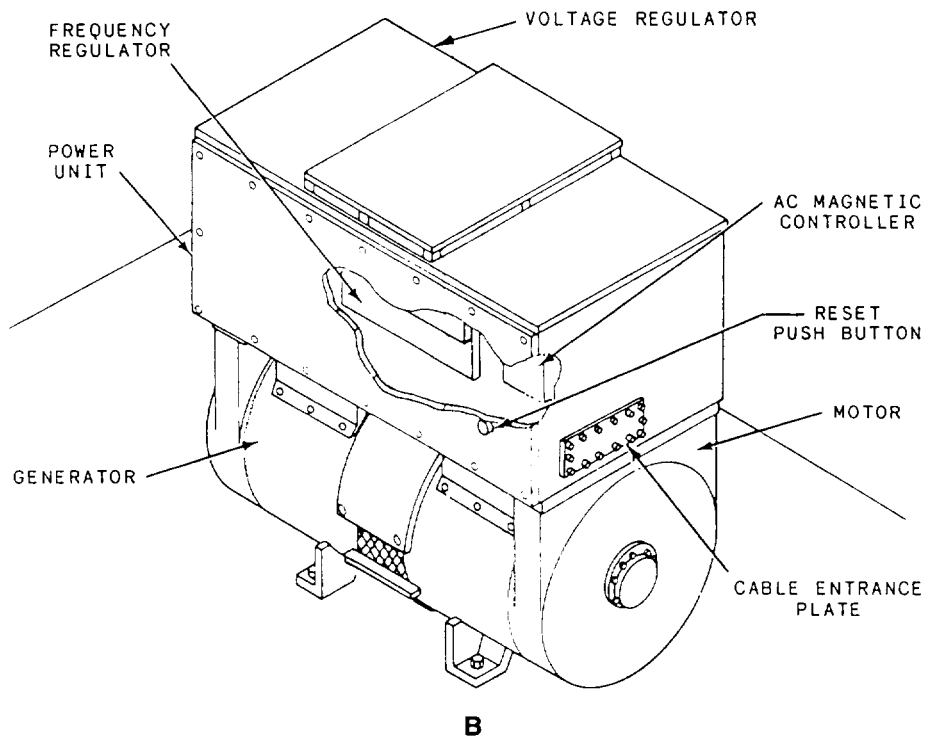
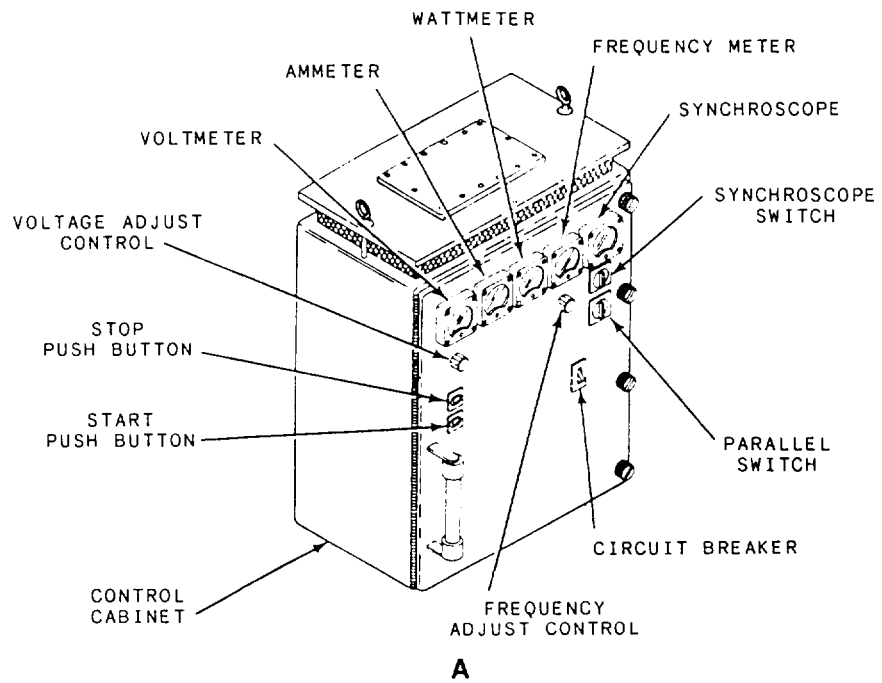

Figure 12-5.—Motor generator.



**Figure 12-6.—30-kW motor generator.**

regulator (fig. 12-6) controls the voltage output of the generator portion of the MG. This voltage may be either 450 volts or 120 volts, depending on the application. The frequency regulator controls the speed of the MG motor, and therefore the output frequency of the MG. Voltage- and frequency-sensing circuits continuously sample the output of the MG and provide feedback to their respective regulators. By doing this, they maintain the output voltage and frequency at the required level (usually to plus or minus one-half percent of the rated value). A magnetic controller is provided to start and stop the unit. It also protects the MG from operating at continuous overload and removes power to the MG if there is an undervoltage condition.

### **STATIC FREQUENCY CHANGERS**

Frequency changers step up and refine the frequency of the ship's 60-Hz electrical power to 400 Hz. Most of the frequency changers installed on board combat ships are static frequency changers. Static frequency changers have no rotating parts—they are all solid state. Static frequency changers are reliable and efficient; they are the only ones that provide the high-quality power demanded by modern weapon systems.

A static frequency changer usually consists of a three-phase rectifier and a three-phase inverter. The rectifier changes the 60-Hz ac incoming power. The inverter converts the dc power delivered by the rectifier into 400-Hz output power through the use of many input filters and transformers.

## **SHIPBOARD POWER DISTRIBUTION**

Most ac power distribution systems in naval ships are 450-volt, three-phase, 60-Hz, three-wire systems. The ship's service generator and distribution switchboards are interconnected by bus ties. This arrangement makes it possible to connect any switchboard to feed power from its generators to one or more of the other switchboards. The bus ties also connect two or more switchboards so that the generator plants can be operated in parallel. In large installations (fig. 12-7), distribution to loads is from the generator and distribution switchboards or switchgear groups to load centers, distribution panels, and the loads, or directly from the load centers to some loads.

On some ships, such as large aircraft carriers, zone control of the ship's service and emergency distribution is provided. A load center switchboard supplies power to the electrical loads within the electrical zone in which it is located. Thus, zone control is provided for all power within the electrical zone. Emergency switchboards may supply more than one zone.

### **GENERATOR AND DISTRIBUTION SWITCHBOARDS**

Ship's service 450-volt, ac switchboards are generally of the dead-front type (no live connections exposed). These switchboards are built to provide efficient and safe operation of the electrical system. A typical power distribution system in a destroyer consists of four generators (two forward and two aft) and two distribution switchboard. The distribution switchboards are set up so that each one controls two generators. All the necessary apparatus for generator control and power distribution is incorporated in its associated switchboard (fig. 12-8).

The ship's forward distribution switchboard is also used as the control switchboard. This switchboard has instruments and controls for the aft generators. These instruments and controls are necessary to parallel the generators to equalize the load. An automatic voltage regulator is mounted on each switchboard to control the generator field excitation and to maintain a constant ac generator voltage during normal changes in load.

Two emergency diesel generator sets provide electric power for limited lighting and for vital auxiliaries if the ship's service power should fail. These units are located in the forward and aft emergency generator rooms. The forward emergency switchboard is normally energized from the forward ship's service switchboard. The aft emergency switchboard is normally energized from the aft ship's service switchboard.

Dc power distribution systems are in use on some older ships that have large deck machinery loads. These systems, which consist of the ship's service generator and distribution switchboards, are similar to the ac systems. On newer ships, dc power is provided at the load with rectifiers that change the ac power to dc power, when required.

### **COMPONENTS OF A SWITCHBOARD**

Each switchboard includes one or more units, such as a bus tie unit, a power distribution unit, lighting distribution units or transformers, and

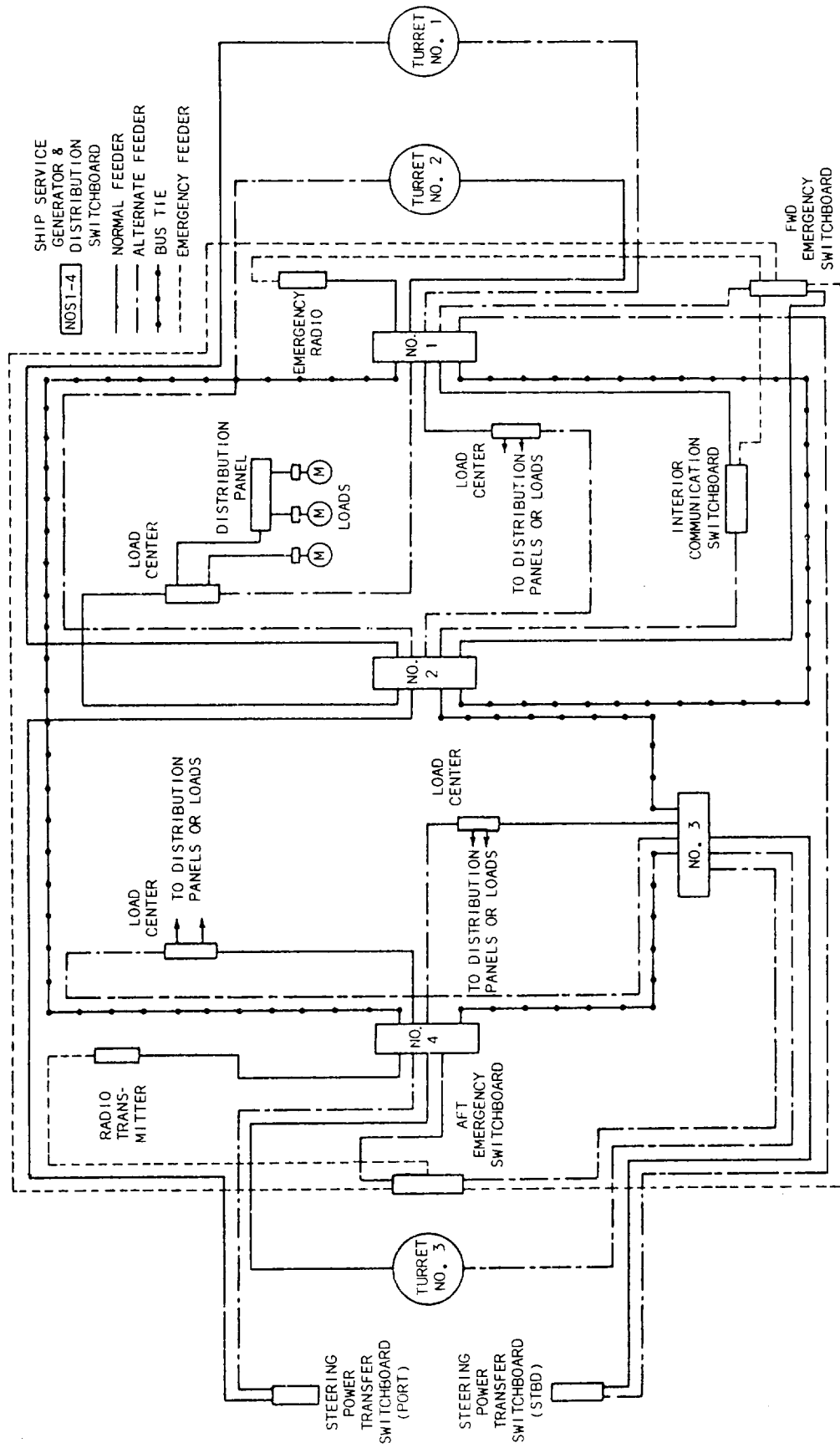

Figure 12-7.—Power distribution in a large combatant ship.

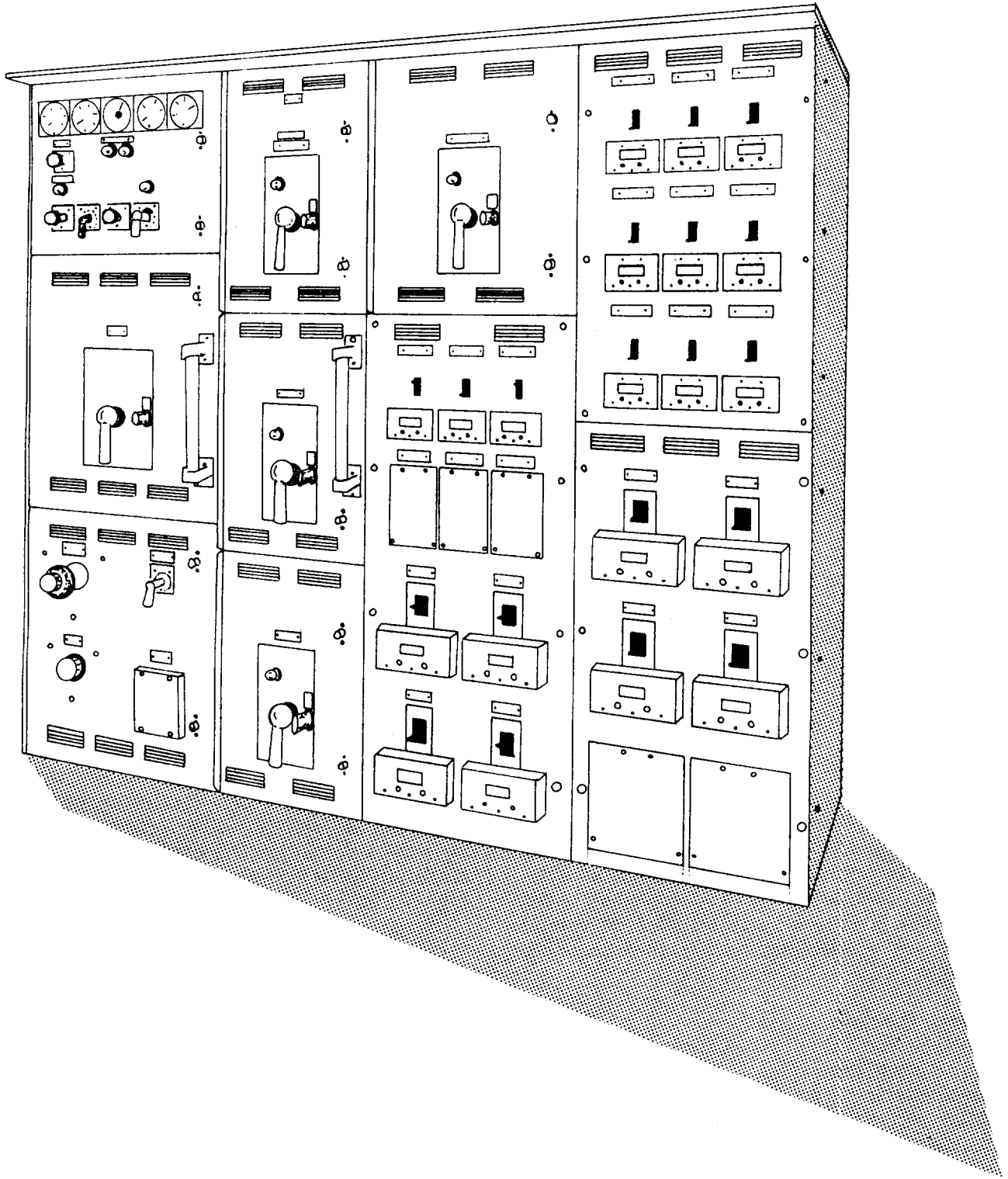
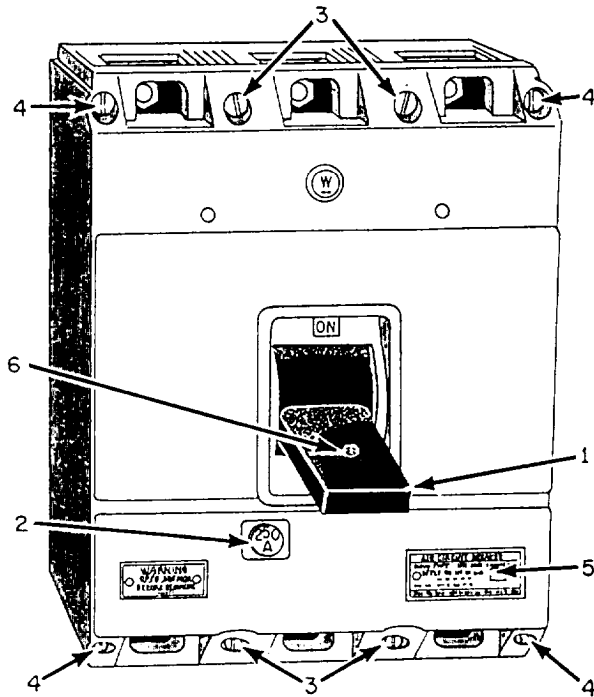

Figure 12-8.—ISB ship's service switchboard, DDG-2 class destroyer.

77.323



- |   |                      |
|---|----------------------|
| 1. Operating handle shown in latched position | 4. Cover screws      |
| 2. Ampere rating marker                       | 5. Breaker nameplate |
| 3. Mounting screws                            | 6. Cotter key hole   |

Figure 12-9.—Circuit breaker.

lighting distribution panels. Large circuit breakers connect ship's service and emergency generators to the power distribution system. They are also used on bus ties and shore connection circuits. Smaller circuit breakers, rated according to the load they handle, are also installed on switchboards and on distribution panels throughout the ship.

### Circuit Breakers

Circuit breakers (fig. 12-9) are used to isolate faulty circuits, to provide a mechanical means to disconnect the electrical power for equipment maintenance, and to serve as overload protection. These circuit breakers are part of the switchboard equipment. Circuit breakers, rather than fuses, are used in circuits that carry large currents. They can be operated for an indefinite period, and their action accurately controlled.

Circuit breakers open automatically when the current (load) on the circuit exceeds a preset value,

Circuit breakers used with shipboard equipment are not susceptible to tripping when subjected to heavy shocks (such as those caused by gunfire). Circuit breakers are used on all rotating electrical machinery and feeders to vital loads, such as gun mounts and searchlights.

In addition to overload relays, reverse power trip relays are provided on ac generator circuit breakers. These units are designed to open and prevent motorizing a generator in the event of a power reversal. They are mounted within the generator switchboard.

### Voltage Regulators

Voltage regulators are installed on the associated switchboards. They are used for ac ship's service and emergency generators. A voltage regulator maintains generator voltage within specified limits. The switchboard operator adjusts or sets the generator voltage at any value within certain limits. When additional loads are applied to a generator, there is a tendency for the voltage to drop. The automatic regulator keeps the voltage of a generator constant at various loads.

### Indicating Meters

All the important switchboards aboard ship are provided with electrical meters. Electrical meters, somewhat like gauges and thermometers, show the operator what is taking place in the electrical machinery and systems. Electrical meters are of two general types—installed meters (on switchboards) and portable meters. Some of the most common meters used are voltmeters, ammeters, kilowatt meters, and frequency meters (fig. 12-10).

## ELECTRIC MOTORS

Electric motors are used aboard ship to operate guns, winches, elevators, compressors, pumps, ventilation systems, and other auxiliary machinery and equipment. There are many reasons for using electric motors: they are safe, convenient, easily controlled, and easily supplied with power.

A motor changes electrical energy into mechanical energy. There are important reasons for changing mechanical energy to electrical energy and back again to mechanical energy. One reason is that electric cables can be led through decks and bulkheads with less danger to



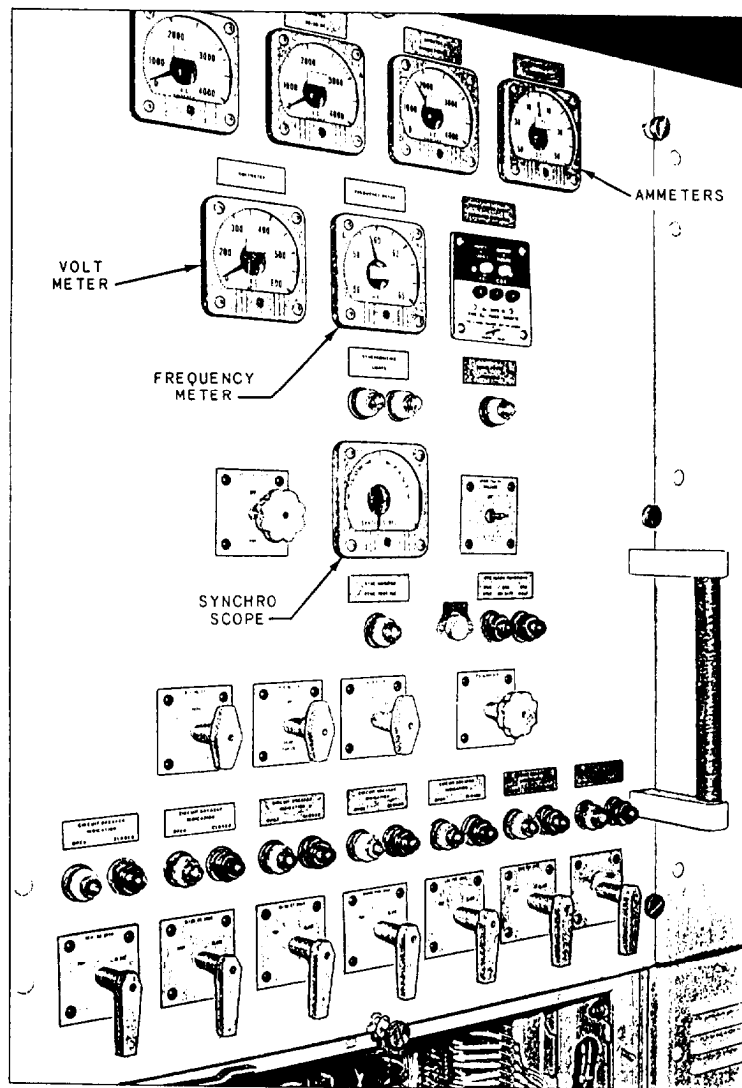

Figure 12-10.—Switchboard indicating meters.

139.76

watertight integrity than steam pipes or mechanical shafts. Another reason is that damage to a steam line can cause steam to escape, resulting in personnel injury. If an electric cable is used and a fault occurs, the circuit breaker protecting the cable opens automatically. The ac motor is used extensively by the Navy because it is smaller and requires less maintenance than the dc motor.

Most ac motors used aboard ship use three-phase, 60-Hz, 450-volt power. Although most ac motors operate at a single speed, some motors, such as the prime movers for fuel oil pumps, lube oil pumps, and ventilation fan motors, have two operating speeds.

## MOTOR CONTROLLERS

Controlling devices are used to start, stop, speed up, or slow down motors. In general, these controllers are standard equipment aboard ship and are operated either manually, semi-automatically, or automatically. They are drip-proof and shock resistant. In some installations, the controllers are operated by remote control, with the switch at a convenient location.

Motor control devices (controllers, master switches, and electric brakes) protect the equipment to which they are connected. Controllers provide protective and governing features for every type of shipboard auxiliary. Various types of master switches are used to govern the

controllers. Electric brakes are used to bring a load to rest, or to hold it at rest, when electric power to the motor is cut off. Aboard ship, electric brakes are used primarily on hoisting and lowering equipment such as cranes, winches, and windlasses.

Most controllers function simply to start or to stop auxiliary machinery; but, some controllers also provide for reversal of direction or multispeed operation. Motor controllers, sometimes called *starters*, have overload protective devices to prevent burning out the motor. Most controllers cut out automatically when the electric power fails, and they have to be restarted manually. This type of motor controller is called a low-voltage protection (LVP) controller. Another type of motor controller, which is used primarily with vital loads, is called a *low-voltage release (LVR) controller*. The LVR controller disconnects the motor from the supply voltage if the supply voltage drops below a predetermined level. When the supply voltage returns to a normal level, the LVR controller automatically restarts the motor.

## BATTERIES

Aboard ship, batteries are one of the sources for emergency and portable power. Storage batteries are used to power emergency equipment, ship's boats, and forklifts. The storage battery is also used as a source of energy for emergency diesel generators, gyrocompasses, and emergency radios.

You should be familiar with safety precautions you must follow when you work around batteries. Batteries must be protected from salt water, which can mix with the electrolyte (the acid solution) and release poisonous gases. Salt water in the electrolyte also sets up a chemical reaction that will ruin the battery. If a battery is exposed to salt water, notify the electric shop immediately.

Storage batteries, when being charged, give off a certain amount of hydrogen gas. Battery compartments should be well ventilated to discharge this gas to the atmosphere.

## WARNING

Flames or sparks of any kind, including lighted cigarettes, should never be allowed in the vicinity of any storage battery that is being charged.

When the battery is in a low or discharged state and does not perform properly, you should notify the Electrician's Mate (EM).

## PORTABLE ELECTRICAL EQUIPMENT

Aboard ship, you will perform many jobs using small, portable electrical tools. Because portable electrical tools are commonly used under a variety of conditions, they are subject to damage and abuse.

The Navy has a good electrical tool safety program. This program is carried out by qualified EMs. However, EMs can only make safety checks on tools that are brought to their attention. Electrical handtools should be inspected before each use to make sure the power cord is not nicked or cut, and the plug is connected properly. Electrical handtools should be turned in to the electricians as prescribed by the electrical safety program.

## BATTLE LANTERNS

Relay-operated hand lanterns (fig. 12-11, view A), usually called *battle lanterns*, are powered by dry-cell batteries. Hand lanterns are provided to give emergency light when the ship's service and emergency/alternate lighting systems fail. These lanterns are placed in spaces where continual illumination is necessary, such as machinery spaces, control rooms, essential watch stations, battle dressing stations, and escape hatches. All auxiliary machinery with gauge boards should be provided with a battle lantern to illuminate the gauge board in the event of a casualty. The battle lantern should not be removed from its mounting bracket except in an emergency. **Do not use it as a flashlight in nonemergency situations.**

The relay control boxes for battle lanterns are connected to the emergency lighting supply circuit (or to the ship's service lighting circuit) in which the lantern is installed. If power in the circuit fails, the relay opens and the batteries energize the lantern.

Relay-operated battle lanterns are capable of operating for a minimum of 10 hours before the light output ceases to be useful.

Similar hand lanterns (fig. 12-11, view B), which are not connected to relays, are installed throughout the ship to provide light in stations

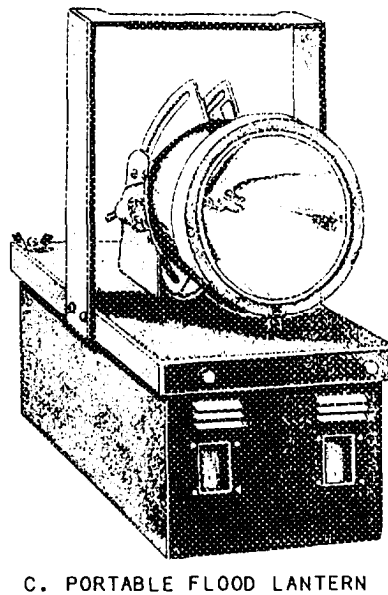
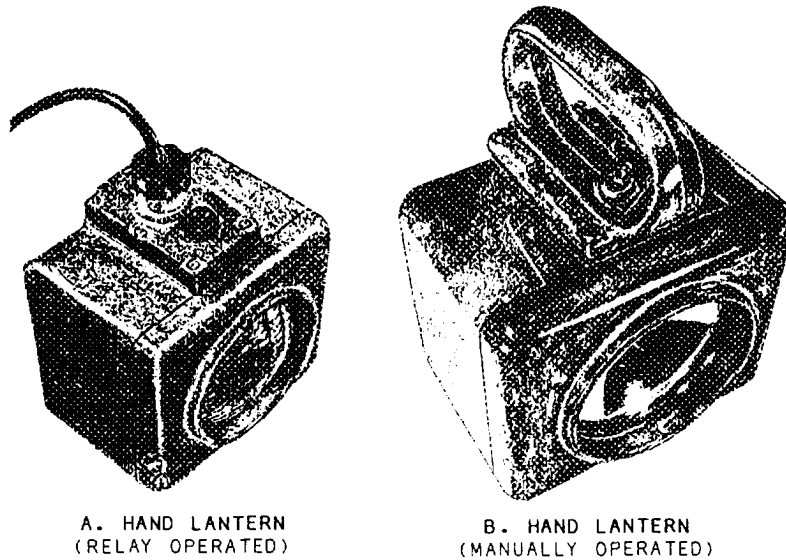

Figure 12-11.—Special lights.

77.47

that are occasionally manned. These lanterns are manually operated. If used in an emergency, the manually operated hand lanterns should ALWAYS BE RETURNED TO THEIR ORIGINAL LOCATION.

**SEALED-BEAM LIGHTS**

Sealed-beam lights are a type of flood lantern (fig. 12-11, view C). These lanterns are used to give high-intensity illumination in damage control or other emergency repair work. These units consist of a sealed-beam light similar to that

used for automobiles. The sealed-beam light, powered by four small wet-cell storage batteries, is mounted in the battery case and fitted with a handle for convenient carrying. A sealed-beam lamp will operate for 3 hours before the batteries require recharging. When the batteries are at full charge, the beam has an intensity similar to that of the headlight on an automobile. At the end of 3 hours, the light output will gradually drop to about one-half its original brilliance. These sealed-beam lights are normally stored in the damage control repair lockers.

## SHIPBOARD ELECTRICAL SYSTEMS AND CONNECTIONS

As a Fireman, you should be familiar with the power and lighting distribution systems, and shore power connections. You will find greater detail on this and other shipboard electrical equipment in chapter 320, *Naval Ships' Technical Manual*.

### POWER DISTRIBUTION SYSTEMS

A power distribution system carries power from the generator switchboards to every part of the ship. This system consists of feeders, mains, submains, load center panels, and distribution boxes. The most important auxiliaries are supplied with normal, alternate, and emergency feeders through automatic bus transfer units, each with a separate source of power. Casualty power systems are installed aboard ship to provide electrical connections when both ship's service and emergency electrical systems are damaged.

### LIGHTING DISTRIBUTION SYSTEMS

Lighting distribution systems are necessary to light the ship and to assist personnel in controlling damage. Two lighting systems are installed aboard combatant ships. These are ship's service lighting and emergency lighting. The ship's service lighting normally supplies all lighting fixtures. Emergency lighting circuits are supplied to vital machinery spaces, the radio room, the combat information center, and other vital spaces. The emergency lighting system receives power from the ship's service generators; but if normal power is lost, the emergency system is automatically powered by the emergency generators. Lighting distribution systems are similar to power distribution systems except for the following differences:

1. They are more numerous.
2. They have lower voltages (120 volts).
3. They have smaller panels and cables.

If an emergency power system is not installed, alternate supplies from another ship's service source can provide for services selected according to the basic principles of an emergency lighting system.

### SHORE POWER CONNECTIONS

Shore power connections are installed at or near suitable weather deck locations. At these

locations, portable cables from the shore, or from a ship alongside, are connected. Power can be supplied through these connections to the switchboard when ship's service generators are not in operation.

## ELECTRICAL SAFETY PRECAUTIONS

There are certain safety precautions you should observe when working with or around electrical appliances and equipment. The following are some of the most common electrical safety precautions all shipboard personnel are required to follow:

- Do not attempt to maintain or repair electrical equipment yourself. Leave the electrical work to the EMs and IC electricians.
- Check personal electrical equipment through the EMs to see if it can be used aboard ship.
- Observe and follow all pertinent instructions and electric warning signs aboard ship.
- Observe all safety precautions regarding portable electric lights and tools. (Use rubber gloves and goggles.)
- Remember, 120-volt electricity is very dangerous, especially aboard ship.
- Do not touch or operate any device that has a danger or caution tag attached to it without first contacting the EOW.
- Do not go behind electrical switchboards.
- Do not touch bare electric wires or connections; assume all circuits to be **ALIVE**.
- Do not remove steamtight globes from lighting fixtures.
- Do not remove battle lanterns from their locations.
- Do not use manually operated hand battle lanterns for unauthorized purposes. Each person should have his/her own flashlight.

- Do not use electric cable runs to hoist or support any weight.
- Do not use the wireways for storage.
- Do not permit water to get into electrical equipment.
- Remember, a flame, spark, or lighted cigarette can cause a disastrous battery explosion.
- Remember, electrolyte from a storage battery can cause severe burns and can damage equipment and clothing.
- When you repair equipment that is driven by a motor, have an electrician disconnect the circuit and tag it as out of commission.
- Do not start or operate electrical equipment when flammable vapors are present.
- Learn the electrical safety precautions applicable to your assigned duties and duty station. By thoroughly understanding electrical safety precautions, you will help prevent injury to yourself and damage to equipment.
- If YOU are ever in doubt about the operating condition of electrical equipment, **CALL AN ELECTRICIAN.**

### **SUMMARY**

This chapter has introduced you to shipboard electrical equipment and systems. It has given you information about electricity, generators, shipboard power distributions, electric motors, controllers, batteries, port able electrical equipment, shipboard electrical systems and connections, and electrical safety precautions. You should pay particular attention to the safety precautions that have been included within this chapter and in all other chapters. Even though electricity has made our lives easier, it can kill you in an instant if it is not used properly.



## CHAPTER 13

# ENVIRONMENTAL CONTROLS

Many materials and situations aboard ship can damage personnel and the environment. Continued emphasis and direction on combating environmental pollution by federal agencies is contained in presidential executive orders and congressional legislation. All facilities owned by, or leased to, the federal government must be designed, operated, maintained, and monitored to conform to applicable air, water, and noise standards established by federal, state, and local authorities.

The Navy actively participates in a program to protect and enhance the quality of the environment. The Navy adheres to all applicable regulatory standards and initiates actions to conserve natural resources, protect historical and cultural properties, and prevent or control pollution caused by Navy facilities. This chapter contains information dealing with some of the more serious problems that threaten the environment. It also covers the controls that are used to reduce the risks.

### HEAT STRESS

On board ship, certain kinds of working spaces may be hot and humid. Some examples of hot and humid spaces are firerooms (boiler rooms), sculleries with automatic dishwashing machines, and galleys.

Heat stress is the basic inability of an individual's body to cope with the effects of a high-temperature and high-humidity environment. When a person works in a hot, humid environment, such as a boiler, heat builds up within his/her body. When the body's capability to cool itself is exceeded, heat stress can occur. The human body tries to cool itself automatically through sweating. Sweating is the mechanism by which the body gets rid of excess heat through evaporation. The sweat evaporates, thereby cooling the body and reducing body temperature. Although the sweating mechanism is a normal body function, the sweating process depletes the body of water and salts and changes the body's chemistry. If liquid volume and salts are not replaced, several heat illnesses or injuries can occur.

### HEAT CRAMPS

Heat cramps are simply painful muscle contractions or spasms. They are normally caused by the loss of body fluids through sweating. It is also possible for a person

who is overheated to induce muscle cramps by drinking cold liquids too quickly or in large quantities. Heat cramps are often an early warning of heat exhaustion. If you ever experience heat cramps, go to a cooler place, drink plenty of cool (not cold) water, and massage the cramping muscles.

**NOTE:** Administering salt in any form, even in drinking water, is POOR health care for victims of heat cramps. The loss of body fluids through sweating results in a HIGHER concentration of salts within the body. If the body's heat load builds up, the muscles will absorb increased amounts of salts. This absorption causes the muscles to cramp.

### HEAT EXHAUSTION

Heat exhaustion is a more serious threat to health than heat cramps. Heat exhaustion usually occurs when personnel work or exercise in hot environments. The body's sweating mechanism is overloaded and cannot cope with the heat buildup within the body. Since the blood flow is disturbed, the victim may feel dizzy, headachy, and nauseated. The signs and symptoms of heat exhaustion are similar to those of shock and should be treated as such. When a person suffers from heat exhaustion, the skin is gray in color and feels cold and clammy. To help the heat exhaustion victim, remove the victim to a cool area and loosen his/her clothing. You should apply cool wet cloths to the head, groin, and ankles and lightly fan the victim. If the victim is conscious, give him/her cool water to drink. If vomiting occurs, do NOT administer any more fluids. Transport the victim to a medical facility as soon as possible.

### HEATSTROKE

Heatstroke is a less common but far more serious threat to health than heat exhaustion. In about 20 percent of heatstroke cases, heatstroke is fatal. In heatstroke, the sweating mechanism breaks down completely; the body is unable to rid itself of excess body heat. The body's temperature may rise as high as 105°F. Prolonged, high body temperatures can cause failure of the brain, kidneys, and liver.

The early symptoms of heatstroke are similar to those of heat exhaustion—headache, nausea, and dizziness. At first, the victim's breathing is deep and rapid; but, as the symptoms progress, breathing becomes shallow, almost absent. The skin appears flushed, dry, and very hot. The pupils are constricted to a pinpoint; the pulse is fast and strong. It is extremely important that you recognize the differences between heat exhaustion and heatstroke. HEATSTROKE IS A TRUE LIFE-AND-DEATH EMERGENCY.

The most important first-aid treatment for a heatstroke victim is to lower the victim's body heat. Move the victim to a cool place. Douse the victim with cold water. Remove as much of the victim's clothing as possible to allow free flow of air over the body to promote cooling. If the victim is conscious, give him/her cool water to drink. Transport the victim to a medical facility as quickly as possible.

So far, we have discussed heat-related problems and the first-aid treatment for heat stress. However, you will be much better off if you learn what you can do to prevent heat stress.

## PREVENTION

In spaces where heat stress is likely to occur, it is difficult to lower temperatures. Therefore, preventing heat stress-related conditions is the goal. Monitoring conditions that bring about heat stress and controlling the crew's exposure to high-heat and high-humidity conditions reduces the chances of heat stress.

Some of the factors that cause heat stress are as follows:

- Unnecessary heat and humidity sources
- Steam leaks
- Damaged insulation

Report these types of conditions so they can be corrected. Vents and exhaust blowers should be adjusted to maintain proper air circulation.

On board ship, spaces are ventilated by ductwork connected to supply (intake) and exhaust blowers. These blowers (or fans) are driven by two-speed electric motors. Exhaust fans have a greater air-moving capacity than supply fans. Unless personnel are otherwise directed, supply and exhaust ventilation fans are set to the SAME speed. It is important that you understand the need to MAINTAIN FLOW. If you do not MAINTAIN FLOW, the following could happen to you. A watch

stander in a hot space sets the supply blower to high speed and then stands under the outlet.

Usually, you can tell whether the speed of the vent blowers for a space is set correctly by how hard it is for you to open or shut the doors to the space. For example, if a door opens outward and it is hard to close, then the space has a POSITIVE pressure. This means that the supply vent is probably set on high speed, and the exhaust vent is set on low speed.

Another common problem with shipboard ventilation systems is improper care of system filters. Filters are installed at the intake of the supply blowers to prevent dust and dirt from entering the ship. Cleaning these filters is considered to be routine maintenance. If, however, filter cleaning is neglected or is poorly done, the temperature of shipboard working and living spaces increases because there is a reduced flow of cooling air. Spaces considered to be heat-stress areas should contain a heat-stress monitor to measure the heat-stress conditions.

On an individual level, wear clothing so there is some air circulation between the clothing and your body. Whenever you perform heavy physical labor, eat lightly and take a rest period before resuming heavy exertion.

The Navy has established strict space environmental monitoring requirements for heat-stress conditions. These *heat-stress surveys*, together with strict exposure limit standard tables, control the amount of time a person may remain in certain high-temperature and high-humidity conditions before being REQUIRED to go to a cool place and rest. For more information about heat injury, you should refer to *Shipboard Heat Stress Control and Personnel Protection*, OPNAVINST 5100.20 (series), and *Navy Occupational Safety and Health (NAVOSH) program Manual for Forces Afloat*, OPNAVINST 5100.19 (series).

Heat illnesses and injuries are primarily caused by the loss of body fluids and salts. Preventing these illnesses and injuries centers on replacing body fluids and salts, monitoring the environment, and controlling exposure. For example, in a hot environment, fluids must be replaced ounce for ounce. Therefore, when you are sweating heavily, increase your water intake proportionately. Meals provide salts to replace those lost through sweating. Therefore, if you work in a high-heat and high-humidity environment, you should eat well-balanced meals at regular intervals, salted to taste. You should get at least 6 hours of sleep every 24 hours. Wear clean clothing made from at least 35 percent cotton. **Do NOT wear starched clothing. Do NOT**



**drink commercially prepared electrolyte supplements in place of water. Do NOT take salt tablets unless specified by medical personnel. Do NOT drink alcoholic beverages, because alcohol depletes the level of fluids in the body.**

Remember, the effects of heat stress are cumulative (add up). Once you have heat cramps, heat exhaustion, or heatstroke, you are twice as likely to experience a heat stress-related incident; your body has an increased sensitivity to heat. Your awareness of the factors that contribute to heat stress and their prevention, as well as your strict adherence to established exposure limits, will help prevent your becoming a victim of heat stress.

## **POLLUTION**

Before understanding how pollution affects you personally, you must take a realistic look at pollution. Pollutants, whether airborne or waterborne, adversely affect the food chain and often are directly harmful to humans. As Navy personnel, our primary concern is to control the pollutants aboard ship to minimize the pollution risk to ourselves and the environment.

### **OIL AND CHEMICAL POLLUTION**

Fuel oil and chemical cleaning solvents are often used aboard Navy ships, and the possibility exists for a spill. These pollutants collect in the ship's bilges. From the ship's bilges, the pollutants are pumped into a waste oil collecting can.

Oily wastes behave just as their definition suggests: an oily waste is any solid or liquid substance that, alone or in a solution, can produce a surface film or *sheen* when it is discharged in clean water. Most oily wastes are derived (come) from petroleum or have characteristics of petroleum products. Waste oil is an oily waste that cannot be reused by the ship, and it contains only small amounts of water. Any mixture that causes a sludge or emulsion to be deposited beneath the surface oil and chemical pollution of the water is considered to be an oily waste.

Oily wastes frequently present a shipboard pollution problem. (Refer to the *Naval Ships' Technical Manual (NSTM)*, chapter 593.) Oily wastes derived from lubricating oils are caused by tank cleaning operations, leakage and drainage from equipment and systems, stripping from contaminated oil-settling tanks, and ballast water from fuel tanks of noncompensated fuel systems during the ship's defueling, refueling, or internal transfer operations.

You may think that if a small amount of oil is pumped overboard, it cannot really cause much damage. Or can it? Remember, oil is less dense than water. It floats on the surface of the water and is carried by the action of winds and tides. Oily wastes can contain appreciable amounts of volatile petroleum or fuel products. When these wastes are confined in spaces, such as tanks and bilge compartments, they become a source of floating flammables or vapors that are potentially hazardous to personnel and equipment. If these vapors collect in a confined area, such as a pocket underneath a pier, they could explode if exposed to an open flame, such as from a welding operation or from a spark from a grinding wheel. Remember, YOU might be the person who is operating the torch, welder, or grinding wheel.

Besides being harmful to the environment and to people, oil and chemical discharge is also against the law. The Oil Pollution Act of 1961 prohibits the discharge of oil and oily waste products into the sea within 50 miles (150 miles in some cases) of land. A more recent law, the Federal Water Pollution Control Act of 1970, prohibits the discharge of oil by any person or agency from any vessel or facility into the navigable waters of the United States inside the 12-mile limit. All oil spills or sheens within the 50-mile prohibited zone of the United States must be reported immediately.

### **Oil Spill Prevention**

Shipboard oil pollution is controlled by the efficient use of the oily waste control system that is incorporated into your ship. Oil pollution control systems reduce oily waste generation, store waste oil and oily wastes, monitor oil and oily wastes, and transfer waste oil and oily wastes to shore facilities. Effective use of your ship's oil pollution control system depends on operators' knowledge of the ship's pollution abatement system. To use your ship's oil pollution control system effectively, operating personnel are trained and plans are made so that oil and oily waste are handled properly. Other requirements for your ship include ensuring that equipment functions properly and that bilges are kept dry and free of oil. The minimum use of detergents is recommended when bilges and equipment are cleaned. Also, always give proper attention to preventive maintenance requirements.

The best prevention method any vessel can use against oil or chemical pollution is not to discharge pollutants into the sea. However, spills do occur during refueling operations. For example, to keep a ship "on an even keel," fuel oil maybe transferred from one tank to

another. Fuel storage tanks are connected by pipes and valves, some of which discharge overboard. All it takes is ONE human error, ONE valve to be open or shut through a vent pipe, and your ship has ONE spill in progress. The simplest solution is to have the people who operate the system do so in a conscientious manner. The people who operate and maintain the pollution control equipment should always be professionally trained and fully qualified.

### **Oil Spill Removal**

If an accident occurs and oil is spilled, your ship should take prompt action to contain the oil and clean it up. A quick reaction by your ship's trained crew results in containment and often collection of the entire spill without the assistance of shore-based personnel.

Every ship should have an Oil Spill Containment and Cleanup Kit (O. S. C. C. K). Instructions for its use can be found in *U.S. Navy Oil Spill Containment and Cleanup Kit, Mark 1*, NAVSEA 0994-LP-013-6010. This manual describes applicable safety precautions for the use of the kit.

The kit consists of various sizes of porous mats, boat hooks, grappling hooks, plastic bags, and an instruction book for their use. If there is a spill, these absorbent mats are used by ship's personnel to soak up the spilled oil. First, soak the porous mats in diesel fuel and wring them out, which causes the mats to soak up the oil instead of water. After they are prepared, throw the mats on the oil spill to soak it up. Then, retrieve the porous mats using the boat hooks and grappling hooks. Next, wring the oil out of the mats into suitable containers. Then, throw the mats back onto the oil spill to soak up more oil. After the oil spill is removed, store the porous mats in plastic bags for disposal at a shore-based facility.

Additionally, containment trawlers can be rigged around a ship in port anytime the ship is engaged in fueling activities. Trawlers are floating fences made up of linked, buoyant *pillows* that confine any spilled oil to the vicinity of the hull.

### **NOISE POLLUTION AND CONTROL**

Another type of pollution, which is often not thought of as pollution, is noise. Prolonged exposure to loud noises is not only psychologically taxing but also a cause of hearing loss. Continued exposure to noise levels of 85 decibels (dB) or greater and impact or impulse noise of 140 dB can cause severe hearing loss. You need to be aware of this problem because spaces in the engineering department can easily have average



**Figure 13-1.-Circumaural (Mickey Mouse) type of ear protection.**

noise levels within the danger range. The Navy has implemented an occupational noise and hearing conservation program. The goal of this program is to eliminate all noise hazards to personnel.

Wherever possible, noise is being reduced by design and insulation. When there are no other practical means available, personal protective hearing devices **MUST** be worn. Furthermore, anyone who works in spaces where noise levels exceed 104 dB must wear a combination of insert-type ear plugs and circumaural-type *ear muffs* (fig. 13-1).

In addition, each person assigned to duties in designated hazardous noise areas are included in the hearing conservation program and receive the required hearing tests within 90 days of that assignment. This procedure serves to determine if a significant hearing loss has occurred. Hazardous noise areas are identified and labeled by either the ship's medical personnel or an industrial hygienist. Audiometric hearing tests are required annually to monitor ship's personnel who are exposed to noise hazards. (Refer to *Navy Occupational Safety and Health (NAVOSH) Program Manual*, OPNAVINST 5100.23 [series].

### **ASBESTOS POLLUTION AND CONTROL**

The inhalation of asbestos fibers can, after a period of years, cause a crippling respiratory condition called *asbestosis*. Exposure to asbestos can also cause several forms of cancer. All personnel who work around asbestos, and who smoke, should be aware that their chance of contracting lung cancer is increased ninetyfold.

The most prevalent use of asbestos materials aboard ship is in the fabrication and repair of pipe and boiler insulation. The greatest hazard is present when asbestos particles (dust) are in the air.

In the interest of personnel safety, the Navy has implemented an asbestos control program. The objective is to eventually replace the asbestos insulating materials with nontoxic materials. In the meantime, the asbestos control program identifies asbestos hazards and implements stringent safety requirements to be followed by personnel working with materials that contain asbestos. Ship personnel are not authorized to remove or repair insulation containing asbestos, except in an operational emergency certified by the commanding officer. Repair and removal work should be referred to the local intermediate maintenance activity (IMA) or contractor.

As you know, the greatest danger from asbestos exists when particles of asbestos are in the air, such as during rip-out of old insulation. Rip-out is normally performed by shipyard personnel; however, you may have to enter a space where there are asbestos particles. If you are ripping out old insulation or staying in the space where rip-out is in progress, you **MUST** wear protective clothing, use a pressure-demand supplied-air respirator (fig. 13-2), and be formally trained on asbestos-handling procedures. After completing your tasks, you **MUST** proceed to the designated decontamination center to remove the coveralls and respirator and to take a shower. These precautions should remove any asbestos particles and prevent the spread of asbestos dust to other sections of the ship.

You should wet down contaminated disposable coveralls. Wet down is a procedure that reduces the possibility of dust being blown off of the coveralls. Then, dispose of the contaminated coveralls in heavy-duty plastic bags. Clearly mark the plastic bags with caution labels to warn personnel of the asbestos hazard.

Insulation materials other than asbestos pose health hazards. For additional information on safe working practices involving these materials, consult the *NSTM*, chapter 635. **REMEMBER**, where safety is concerned, take nothing for granted. Your actions can have a positive or negative effect on you and your shipmates.

### **REFRIGERANTS AND SAFETY PRECAUTIONS**

The refrigerants commonly used are fluids, and they are affected by heat, temperature, and pressure in a



**Figure 13-2.** Disposable protective coveralls and type C respirator.

manner similar to water. Many different fluids are used as refrigerants; their selection is based on low boiling points and other desirable characteristics. The following refrigerants are the most commonly used on U.S. Navy ships:

R-11, trichlorofluoromethane. R-11 is a colorless liquid or gas. At room temperature, R-11 has a slight ethereal odor (smells like ether or dry-cleaning fluid, tetrachloroethylene).

R-12, dichlorodifluoromethane. R-12 is a colorless and odorless gas at room temperature. In high concentration, it has a slight ethereal odor.

**NOTE:** Dichlorodifluoromethane (formerly F-12), is now called R-12.

R-22, monochlorodifluoromethane. R-22 is a colorless and odorless gas, which, at room temperature in high concentration, has a slight ethereal odor.

R-114, dichlorotetrafluoroethane. R-114 is a colorless and odorless gas, which, at room temperature in high concentration, has a slight ethereal odor.

R-113, trichlorotrifluoroethane. R-113 is a heavy colorless liquid, which, at room temperature, has a slight ethereal odor. R-113 is only used as a solvent, degreaser, and flushing agent. It is not used as a shipboard refrigerant.

These refrigerants, liquid and vapor, are nonflammable and nonexplosive. Air mixtures of these refrigerants are not capable of producing a flame. The products of decomposition have a pungent odor and are very irritating in minute quantities. They give ample warning before dangerous concentrations are reached.

R-12, R-22, and R-114 are shipped under pressure in steel cylinders. R-11 and R-113 are normally shipped in drums, although some R-11 is shipped in cylinders for submarine use. The refrigerant cylinders are easily identified by their orange-colored bodies. In addition, the following markings are made on the cylinder to minimize the possibility of misidentification of the gas:

- The name of the gas is stenciled longitudinally on two diametrically opposite sides of the cylinder.
- A decal bearing the name of the gas may be attached to the shoulder of the cylinder 90 degrees from the stenciling.

### **WARNING**

Do not smoke, braze, or weld when refrigerant vapors are present. Vapors decompose to phosgene, acid vapors, and other products when exposed to an open flame or a hot surface.

The following safety precautions and warnings apply to all of the refrigerants listed in the previous paragraphs.

- Exposure to large concentrations of fluorocarbon refrigerants can be fatal. Vapors displace air (oxygen) in a space and result in asphyxia. In high concentrations, these vapors have an anesthetic effect, causing stumbling, shortness of breath, irregular or missing pulse, tremors, convulsions, and death. Fluorocarbon refrigerants and solvents should, therefore, be treated as toxic gases.

- Initial adverse anesthetic effects of R-113 can be experienced at much lower levels than those of other refrigerants, even though all refrigerants listed here have a threshold limit value (TLV) of 1,000 parts of refrigerant per million parts of air (ppm).

- Personnel overcome by inhalation of fluorocarbon vapors may develop cardiac problems. Remove exposed personnel to fresh air immediately. If breathing has stopped, apply artificial respiration. **Do not permit affected personnel to exert themselves or to exercise.**

TLVs refer to airborne concentrations of substances and represent conditions under which it is believed that nearly all workers may be repeatedly exposed for an 8-hour day, 40 hours per week without adverse effects. In addition to the precautions previously stated, there are other safety measures that should be followed. A few of these methods and precautions are as follows:

- Because refrigerants R-12 and R-22 boil at such low temperatures, they may freeze if they are splashed into the eyes or onto the skin. Always wear chemical safety goggles or a full face shield when you work with any refrigerant. Wear long-sleeved shirt and protective gloves.

- Vapors of fluorocarbon refrigerants are four to five times heavier than air and tend to collect in low places. Perform refrigerant detection within 2 feet of the deck and in possible air pockets.

- Refrigeration machinery spaces should be well ventilated, especially when personnel are servicing machinery. Use portable blowers if necessary to keep the refrigerant vapor levels below the TLV of 1,000 ppm.

- Always have two people present when work is being done on refrigeration systems. Use a halide monitor with an alarm so you can be sure refrigerant vapor concentrations in a space do not exceed safe limits.

### **SEWAGE SYSTEM**

In a continuing effort to control pollution of inland and coastal waters, the Navy is installing sewage treatment systems on board naval ships. These marine sanitation systems are composed of three subsystems:

- Flushing water system (provides flushing water)
- Collection system (collects waste)
- Treatment disposal system (treats and disposes of waste)

Sewage discharged by naval ships into rivers, harbors, and coastal waters and the environmental effects of sewage pollution are of great concern to the Navy. In fact, the Navy is required to control sewage

discharge under regulations issued by the Secretary of Defense.

In the past, shipboard sewage has been discharged overboard as a matter of routine design and operation. Studies have shown that concentrations of sewage in inland waters, ports, harbors, and coastal waters of the United States is detrimental to the environment. The Navy has installed marine sanitation devices (MSDs) on ships. The MSDs allow ships to comply with the sewage discharge standards without compromising mission capability.

In 1972, the Chief of Naval Operations (CNO) made the policy decision to install the sewage collection, holding, and transfer (CHT) system aboard naval ships. The CHT system is designed to hold all shipboard sewage that is generated over a 12-hour period. On large ships, this goal can usually be achieved. For smaller ships, the maximum capacity would limit holding time to 3 hours or less, an insufficient time for the ship to transit the 3-mile restricted zone.

The Jered sewage treatment plant and the LHA sewage treatment plant are other types of MSD systems. The Jered sewage treatment plant is designed for a zero liquid discharge. It is capable of using the vacuum-burn principle. Sewage is first collected by a vacuum and then disposed of by incineration. Sewage can be discharged overboard when the ship is at sea or pumped to shore via a connection facility. The LHA sewage treatment plant is a biological sewage treatment process in which sewage and activated sludge can be mixed and aerated. The activated sludge is separated from the treated sewage by sedimentation and discharged or returned to the process as needed.

There are distinct hazards to personnel associated with all sewage systems. These hazards include explosive gases, toxic vapors, and biological contaminants. When operating a CHT system, for example, personnel must be extremely careful so spills do not occur. **ALL SPILLS CAN BE EXTREMELY HAZARDOUS TO PERSONNEL.**

In addition to the removal of CHT contaminants, CHT spills are sanitized with disinfectants so that residual bacteria are eliminated. Medical department personnel must be notified of any CHT *black water* spills. Medical department personnel must also supervise cleanup and sanitation operations in spill areas.

For further information on sanitation systems, refer to *Hull Maintenance Technician 3 & 2*, volume I, NAVEDTRA 10571 (series), chapter 15, and *NSTM*, chapter 593.

## SUMMARY

This chapter introduced you to environmental hazards and control. Remember, pollution takes many shapes and forms. Pollution attacks the environment and directly or indirectly affects each of us. Consequently, we must protect the environment by preventing pollution.

On board ship, certain forms of pollution are sometimes difficult to control, such as heat and noise. In these cases, the first line of defense is PROTECTION. In all other cases, we must be concerned with PREVENTION. Keep in mind that prevention of pollution, in any form, is everybody's business. Pollute your environment, and your environment will pollute you.



# APPENDIX I

## GLOSSARY

- AUTOMATIC COMBUSTION CONTROL (ACC) SYSTEM**—A system that automatically controls the fuel and air mixture in a boiler.
- AUXILIARY MACHINERY**—Any system or unit of machinery that supports the main propulsion units or helps support the ship and the crew; for example, pump, evaporator, steering engine, air-conditioning and refrigeration equipment, laundry and galley equipment, and deck winch.
- BACK PRESSURE**—The pressure exerted on the exhaust side of a pump or engine.
- BALLASTING**—The process of filling empty tanks with seawater to protect the ship from underwater damage and to increase its stability See DEBALLAST-ING.
- BLOW TUBES**—Use of steam to remove soot and carbon from the tubes of steaming boilers.
- BLUEPRINT**—Reproduced copy of a drawing (usually having white lines on a blue background).
- BOTTOM DEAD CENTER (BCD)**—The position of a reciprocating piston at its lowest point of travel.
- BOILER**—A strong metal tank or vessel, composed of tubes, drums, and headers, in which water is heated.
- BOILER CENTRAL CONTROL STATION**—A centrally located station for directing the control of all boilers in the fireroom.
- BOILER DESIGN PRESSURE**—Pressure specified by the manufacturer, usually about 103 percent of normal steam drum operating pressure.
- BOILER INTERNAL FITTINGS**—All parts inside the boiler that control the flow of steam and water.
- BOILER OPERATING PRESSURE**—The pressure at which a boiler is maintained while in service.
- BOILER OPERATING STATION**—A location from which a boiler is operated.
- BOILER RECORD SHEET**—A NAVSHIPS form maintained for each boiler, which serves as a monthly summary of operation.
- BOILER REFRACTORIES**—Materials used in the boiler furnace to protect the boiler from heat.
- BOILER ROOM**—A compartment containing boilers but not containing a station for operating or firing the boilers Refers specifically to bulkhead-enclosed boiler installations.
- BOILER TUBE CLEANER**—A cylindrical brush that is used to clean the insides of boiler tubes.
- BOILER WATER**—The water actually contained in the boiler.
- BOTTOM DEAD CENTER (BCD)**—The position of a reciprocating piston at its lowest point of travel.
- BOURDON TUBE**—A thin-walled tube bent into the shape of a letter C, which tends to straighten out when pressure is exerted. As the tube straightens, it moves a pointer around a gauge dial.
- BRAZING**—A method of joining two metals at high temperature with a molten alloy.
- BRINE**—A highly concentrated solution of salt in water, normally associated with the overboard discharge of distilling plants.
- BRITTLENESS**—A property of a material that causes it to break or snap suddenly with little or no prior sign of deformation.
- BULL GEAR**—The largest gear in a reduction gear train The main gear, as in a geared turbine drive.
- BURNERMAN**—Person in the fireroom who tends the burners in the boilers.
- BUSHING**—A renewable lining for a hole through which a moving part passes.
- BYPASS**—To divert the flow of gas or liquid Also, the line that diverts the flow.
- CALIBRATION**—The comparison of any measuring instrument with a set standard of a greater accuracy.
- CANTILEVER**—A projecting arm or beam supported only at one end.
- CAPILLARY TUBE**—A slender, thin-walled, small-bored tube used with remote-reading indicators.

**CARBON DIOXIDE**—A colorless, colorless gas used as a fire-extinguishing agent and for inflating life rafts and life jackets.

**CARBON PACKING**—Pressed segments of graphite used to prevent steam leakage around shafts.

**CASUALTY POWER SYSTEM**—Portable cables that are rigged to transmit power to vital equipment in an emergency.

**CENTRAL CONTROL STATION (CCS)**—The CCS is the main operating station from which a majority of the engineering plant machinery can be controlled and monitored on modern naval ships.

**CHECK VALVE**—A valve that permits the flow of a liquid in one direction only.

**CIRCUIT BREAKER**—An electrical device that provides circuit overload protection.

**CLUTCH**—A form of coupling designed to connect or disconnect a driving or driven member.

**COLD IRON**—The condition of an idle engineering plant when all port services are received from an external source such as shore or tender.

**CONDENSATE**—Water produced in the cooling system, of the steam cycle, from steam that has returned from the turbine or from steam that has returned from various heat exchangers.

**CONDENSER**—A heat-transfer device in which steam or vapor is condensed to water.

**CONDUCTION**—A method of heat transfer from one body to another when the two bodies are in physical contact.

**CONSTANT PRESSURE GOVERNOR**—A device that maintains a constant pump discharge pressure under varying loads.

**CONTROLLABLE REVERSIBLE-PITCH PROPELLER (CRPP)**—A propeller whose blade pitch can be varied to control the amount of thrust in both ahead and astern directions.

**CONTROLLER**—A device used to stop, start, and protect motors from overloads while the motors are running.

**COOLER**—Any device that removes heat.

**CORROSION**—The process of being eaten away gradually by chemical action, such as rusting.

**COUNTERSINK**—A cone-shaped tool used to enlarge and bevel one end of a drilled hole.

**CREEP-RESISTANT ALLOY**—A metal that resists the slow plastic deformation that occurs at high temperatures when the material is under constant stress.

**CROSS-CONNECTED PLANT**—A method of operating two or more systems as one unit.

**CURTIS STAGE**—A velocity-compounded impulse turbine stage that has one pressure drop in the nozzles and two velocity drops in the blading.

**DEAERATING FEED TANK (DFT or DA tank)**—A device used in the waste-heat boiler system to remove dissolved oxygen and noncondensable gases from the feedwater.

**DEBALLASTING**—The process by which seawater is emptied from tanks to protect the ship from underwater damage and to increase its stabilitySee BALLASTING.

**DEGREE OF SUPERHEAT**—The amount by which the temperature of steam exceeds the saturation temperature.

**DIESEL FUEL MARINE**—A fuel oil.

**DIRECT CURRENT (dc)**—current that moves in one direction only.

**DIRECT DRIVE**—One in which the drive mechanism is coupled directly to the driven member.

**DISTILLATE**—Water produced in distilling plants.

**DISTILLING PLANT**—A system that converts seawater into fresh water commonly called evaporators (evaps).

**DRAWING**—An illustrated plan that shows fabrication and assembly details.

**DRUM, STEAM**—The large tank at the top of the boiler in which the steam collects.

**DRUM, WATER**—A tank at the bottom of a boiler.

**DUCTILITY**—The property possessed by metals that allows them to be drawn or stretched.

**ECONOMIZER**—A heat-transfer device on a boiler that uses the gases of combustion to preheat the feedwater.

**EDUCTOR**—A jet pump that uses water to empty flooded spaces.

**EFFICIENCY**—The ratio of the output to the input.

**ELASTICITY**—The ability of a material to return to its original size and shape.



**ELECTRODE**—A metallic rod (welding rod) used in electric welding. It melts when current is passed through it.

**ELECTROHYDRAULIC STEERING**—A system having a motor-driven hydraulic pump that creates the force needed to position the ship's rudder.

**ELECTROLYSIS**—A chemical action that takes place between unlike metals in systems using salt water.

**ELECTROMOTIVE FORCE (emf)**—A force that causes electrons to move through a closed circuit, expressed in volts.

**ELEMENT**—A substance that consists of chemically united atoms of one kind.

**ENERGY**—The capacity for doing work.

**ENGINE ORDER TELEGRAPH (EOT)**—A device on the ship's bridge that is used to give orders to the engine room. Also called annunciator.

**ENGINEER'S BELL BOOK**—A legal record of all ordered main engine speed changes.

**ENGINEERING OFFICER OF THE WATCH (EOOW)**—officer on duty in the engineering spaces.

**ENGINEERING OPERATING STATION (EOS)**—

**EQUIVALENTS PER MILLION (EPM)**—The number of equivalent parts of a substance per million parts of another substance. The word equivalent refers to the equivalent chemical weight of a substance.

**EROSION**—A gradual wearing away, such as a gully that is eroded by water.

**EVAPORATOR**—A distilling device that produces fresh water from seawater.

**EXPANSION JOINT**—A junction that allows for expansion and contraction.

**FATIGUE**—The tendency of a material to break under repeated strain.

**FEED HEATER**—A heat-transfer device that heats the feedwater before it goes to the boiler.

**FEEDWATER**—Water of the highest possible level of purity made in evaporators for use in boilers.

**FERROUS METAL**—Metal with a high iron content.

**FIREBOX**—The section of a ship's boiler where fuel oil combustion takes place.

**FIRE MAIN**—The saltwater line that provides fire-fighting water and flushing water throughout the ship.

**FIRE TUBE BOILER**—A boiler in which the gases of combustion pass through the tubes and heat the water surrounding them.

**FLAREBACK**—A backfire of flame and hot gases into a ship's fireroom from the firebox. Caused by a fuel oil explosion in the firebox.

**FLASH POINT OF OIL**—The temperature at which oil vapor will flash into fire, although the main body of the oil will not ignite.

**FLEXIBLE I-BEAM**—An I-shaped steel beam on which the forward end of a turbine is mounted; it allows for longitudinal expansion and contraction.

**FLOOR (DECK) PLATES**—The removable deck plating of a fireroom or engine room aboard ship.

**FLUID**—A substance that tends to flow or conform to the shape of a container.

**FLUX**—A chemical agent that retards oxidation of the surface, removes oxides already present, and aids fusion.

**FORCE**—Anything that tends to produce or modify motion.

**FORCED DRAFT**—Air under pressure supplied to the burners in a ship's boiler.

**FORCED-DRAFT BLOWERS**—Turbine-driven fans that supply air to the boiler furnace.

**FORCED-FEED LUBRICATION**—A lubrication system that uses a pump to maintain pressure.

**FORGING**—The forming of metal by heating and hammering.

**FRESHWATER SYSTEM**—A piping system that supplies fresh water throughout the ship.

**FUEL OIL MICROMETER VALVE**—A valve, installed at the burner manifold, that controls the fuel oil pressure to the burners.

**FUEL OIL SERVICE TANKS**—Tanks that provide suction to the fuel oil service pumps for use in the fuel oil service system.

**FUSE**—A protective device that will open a circuit if the current flow exceeds a predetermined value.

**GALLONS PER MINUTE (GPM or gpm)**—A unit of measurement.

- GAS FREE**—A term used to describe a space that has been tested and found safe for hot work (welding and cutting).
- GAS GENERATION (GG)**—The high-pressure section of the main propulsion gas turbine. It includes the compressor, combustor, high-pressure turbine, front frame, compressor rear frame, turbine mid frame, transfer gearbox, and the controls and accessories.
- GAUGE (SIGHT) GLASS**—A device that indicates the liquid level in a tank.
- GEARED-TURBINE DRIVE**—A turbine that drives a pump, generator, or other machinery through reduction gears.
- GROUNDING PLUG**—A three-pronged electrical plug used to ground portable tools to the ship's structure. It is a safety device that must always be checked before portable electrical tools are used.
- HALIDE LEAK DETECTOR**—A device used to locate leaks in refrigeration systems.
- HANDHOLE**—An opening large enough for the hand and arm to enter for making slight repairs and for inspection purposes.
- HARDENING**—The heating and rapid cooling (quenching) of metal to induce hardness.
- HEADER**—A large pipe to which smaller pipes are connected so that the liquid may pass freely from one pipe to the other(s).
- HEAT EXCHANGER**—Any device that allows the transfer of heat from one fluid (liquid or gas) to another.
- HERTZ**—A unit of frequency that equals 1 cycle per second.
- HYDROGEN**—A highly explosive, light, invisible, nonpoisonous gas.
- HYDROMETER**—An instrument used to determine the specific gravity of liquids.
- HYDROSTATIC TEST**—A pressure test that uses water to detect leaks in closed systems.
- IGNITION, COMPRESSION**—The heat generated by compression in an internal combustion engine that ignites the fuel (as in a diesel engine).
- IGNITION SPARK**—The electric spark that ignites the mixture of air and fuel in an internal combustion engine (as in a gasoline engine).
- IMPELLER**—An encased, rotating element provided with vanes that draws in fluid at the center and expels it at a high velocity at the outer edge.
- IMPULSE TURBINE**—A turbine in which the major part of the driving force is received from the impulse of incoming steam. See REACTION TURBINE.
- INDIRECT DRIVE**—A drive mechanism coupled to the driven member by gears or belts.
- INERT**—Inactive.
- INJECTOR**—A device that forces a fluid into an area. Injectors are used in the diesel engine to deliver fuel into the cylinders and in boilers to force water into the boilers.
- INSULATION**—A material used to retard heat transfer.
- INTERCOOLER**—An intermediate heat transfer unit between two successive stages, as in an air compressor.
- JACKBOX**—A receptacle, usually secured to a bulkhead, into which telephone plugs or jacks are inserted.
- JOB ORDER**—An order issued by a repair activity to its own subdivision to perform a repair job in response to a work request.
- JP5**—A fuel oil similar to DFM.
- JUMPER**—Any connecting pipe, hose, or wire normally used in emergencies aboard ship to bypass damaged sections of a pipe, a hose, or a wire. See BYPASS.
- JURY RIG**—Any temporary or makeshift device.
- LABYRINTH PACKING**—Rows of metallic strips or fins that minimize steam leakage along the shaft of a turbine.
- LAGGING**—A protective and confining cover placed over insulating material.
- LIGHT OFF**—To start a tire, as in light off a boiler.
- LINE UP**—To align a system for operation.
- LOGBOOK**—Any chronological record of events, such as an engineering watch log.
- LOG, ENGINEERING**—A legal record of important events and data concerning the machinery of a ship.
- LOGROOM**—The engineer's office aboard ship.
- LUBE OIL PURIFIER**—A unit that removes waste and sediment from lubricating oil by centrifugal force.

**MACHINABILITY**–The ease with which a metal may be turned, planed, milled, or otherwise shaped.

**MAIN CONDENSER**–A heat exchanger that converts exhaust steam to feedwater.

**MAIN DRAIN SYSTEM**–A system used for pumping bilges; consists of pumps and associated piping.

**MAIN INJECTION (SCOOP INJECTION)**–An opening in the skin of a ship through which cooling water is delivered to the main condenser and main lube oil cooler by the forward motion of the ship.

**MAKEUP FEED**–Water of required purity for use in ship's boilers This water is needed to replace water lost in the steam cycle.

**MALLEABILITY**–That property of a material that enables it to be stamped, hammered, or rolled into thin sheets.

**MANIFOLD**–A fitting with numerous branches that directs fluids between a large pipe and several smaller pipes.

**MANUAL BUS TRANSFER (MBT)**–A device that will transfer electrical power from the normal power supply to an alternate power supply, manually.

**MECHANICAL ADVANTAGE (MA)**–The advantage (leverage) gained by the use of devices, such as a wheel to open a large valve, chain falls and block and tackle to lift heavy weights, and wrenches to tighten nuts on bolts.

**MECHANICAL CLEANING**–A method of cleaning the fire sides of boilers by scraping and wire brushing.

**MICROMHOS**–Electrical units used with salinity indicators to measure the conductivity of water.

**MICRON**–A unit of length equal to 1 millionth of a meter.

**MOTOR GENERATOR SET**–A machine that consists of a motor mechanically coupled to a generator and usually mounted on the same base.

**NIGHT ORDER BOOK**–A notebook containing standing and special instructions from the engineering officer to the night engineering officers of the watch.

**NITROGEN**–An inert gas that will not support life or combustion.

**NONFERROUS METALS**–Metals that are composed primarily of some element or elements other than iron (usually nonmagnetic).

**OIL KING**–A petty officer who receives, transfers, discharges, and tests fuel oil and maintains fuel oil records; certified to test and treat boiler water and feedwater.

**OIL POLLUTION ACTS**–The Oil Pollution Act of 1924 (as amended), the Oil Pollution Act of 1961, and the Federal Water Pollution Control Act of 1970 prohibit the overboard discharge of oil or water that contains oil, in port, in any sea area within 50 miles of land, and in special prohibited zones.

**ORIFICE**–A small opening that restricts flow, such as an orifice plate in a water piping system.

**OVERLOAD RELAY**–An electrical protective device that automatically trips when a circuit draws excessive current.

**OXIDATION**–The process of various elements and compounds combining with oxygenThe corrosion of metals is generally a form of oxidation; for example, rust on iron is due to oxidation.

**PANT, PANTING**–A series of pulsations caused by minor, recurrent explosions in the firebox of a ship's boilerUsually caused by a shortage of air.

**PARTS PER MILLION (PPM)**–Comparison of the number of parts of a substance with a million parts of another substanceUsed to measure the salt content of water.

**PITOMETER LOG**–Device that indicates the speed of a ship and the distance traveled by measuring water pressure on a tube projected outside the ship's hull.

**PLASTICITY**–A property that enables a material to be excessively and permanently deformed without breaking.

**PREHEATING**–The application of heat to the base metal before it is welded or cut.

**PRIME MOVER**–The source of motion, such as a turbine or an automobile engine.

**PUNCHING TUBES**–Process of cleaning the interiors of tubes.

**PURPLE-K POWDER (PKP)**–A fire - extinguishing agent.

**PYROMETER**–An instrument used for measuring temperatures.

**RADIATION, HEAT**–Heat emitted in the form of heat waves.

**REACH RODS**–A length of pipe used as an extension on valve stems.

**REACTION TURBINE**–A turbine in which the major part of the driving force is received from the reactive force of steam as it leaves the blading. See **IMPULSE TURBINE**.

**REDUCE**–Any coupling or fitting that connects a large opening to a smaller pipe or hose.

**REDUCING VALVES**–Automatic valves that provide a steady pressure lower than the supply pressure.

**REDUCTION GEAR**–A set of gears that transmit the rotation of one shaft to another at a slower speed.

**REEFER**–A refrigerated compartment. Authorized abbreviation for refrigerator.

**REFRACTORY**–Various types of heat-resistant, insulating material used to line the insides of boiler furnaces.

**REFRIGERANT 12 (R-12)**–A nonpoisonous gas used in air-conditioning and refrigeration systems.

**REGULATOR (GAS)**–An instrument that controls the flow of gases from compressed gas cylinders.

**REMOTE OPERATING GEAR**–Flexible cables attached to valve wheels so that the valves can be operated from another compartment.

**RISER**–A vertical pipe leading off a large horizontal pipe; for example, a fire main riser.

**ROTARY SWITCH**–An electrical switch that closes or opens the circuit by a rotating motion.

**ROTOR**–The rotating part of a turbine, pump, electric motor, or generator.

**SAE**–Abbreviation for the Society of Automotive Engineers.

**SAFETY VALVE**–An automatic, quick opening and closing valve that has a reset pressure lower than the lift pressure.

**SALINITY**–Relative salt content of water.

**SALINOMETER**–A hydrometer that measures the concentration of salt in a solution (brine density).

**SATURATION PRESSURE**–The pressure corresponding to the saturation temperature.

**SATURATION TEMPERATURE**–The temperature at which a liquid boils under a given pressure. For any given saturation temperature, there is a corresponding saturation pressure.

**SCALE**–An undesirable deposit, mostly calcium sulfate, that forms in the tubes of boilers and distilling plants.

**SECURE**–To make fast or safe—the order given on completion of a drill or exercise. The procedure followed when any piece of equipment is to be shut down.

**SENTINEL VALVES**–Small relief valves used primarily as a warning device.

**SHAFT ALLEY**–The compartment of a ship that propeller shafts pass through.

**SKETCH**–A rough drawing indicating major features of an object.

**SLIDING FEET**–A mounting for turbines and boilers that allows for expansion and contraction.

**SLUDGE**–The sediment left in fuel oil tanks, lube oil sumps, and boiler water drums.

**SOLID COUPLING**–A device that joins two shafts rigidly.

**SOOT BLOWER**–A soot removal device that uses a steam jet to clean the fire sides of a boiler.

**SPECIFIC HEAT**–The amount of heat required to raise the temperature of 1 pound of a substance 1°F. All substances are compared to water that has a specific heat of 1 Btu/lb/°F.

**SPEED-LIMITING GOVERNOR**–A device that limits the rotational speed of a prime mover.

**SPEED-REGULATING GOVERNOR**–A device that maintains a constant speed on a piece of machinery that is operating under varying load conditions.

**SPLIT PLANT**–A method of operating an electrical or propulsion plant so that it is divided into two or more separate and complete units.

**SPRING BEARINGS**–Bearings positioned at varying intervals along a propulsion shaft to help keep it in alignment and to support its weight.

**STANDBY EQUIPMENT**–Two identical auxiliaries that perform one function. When one auxiliary is running, the standby is connected so that it may be started if the first fails.

**STATIC**–A force exerted by reason of weight alone as related to bodies at rest or in balance.

**STEAMING WATCH**—Watches stood when the main engines are in use and the ship is underway.

**STEAM LANCE**—A device that uses low-pressure steam to remove soot from inside boilers and to remove carbon from boiler tubes.

**STEERING ENGINE**—The machinery that turns the rudder.

**STERN TUBE**—A watertight enclosure for the propeller shaft.

**STRAIN**—The deformation, or change in shape, of a material that results from the weight of an applied load.

**STRENGTH**—The ability of a material to resist strain.

**STRESS**—A force that produces or tends to produce deformation in a metal.

**STUFFING BOX**—A cavity in which packing is placed to prevent leakage between a moving shaft and a fixed part of a valve or pump.

**STUFFING TUBE**—A packed tube that makes a watertight fitting for a cable or small pipe passing through a bulkhead.

**SUMP**—A container, compartment, or reservoir used as a drain or receptacle for fluids.

**SUPERHEATER**—A unit in the boiler that dries the steam and raises its temperature.

**SWASHPLATES**—Metal plates in the lower part of the steam drum that prevent the surging of boiler water with the motion of the ship.

**SWITCHBOARD**—A panel or group of panels that distribute electrical power throughout the ship, normally with automatic protective devices.

**TAKE LEADS**—A method of determining bearing clearance.

**TANK TOP**—The top side of tank section or double bottom of a ship.

**TOP DEAD CENTER (TDC)**—The position of a reciprocating piston at its uppermost point of travel.

**TEMPERING**—The heating and controlled cooling of a metal to produce the desired hardness.

**THIEF SAMPLE**—A sample of oil or water taken for analysis.

**THROTTLEMAN**—The person in the engine room who operates the throttles to control the main engines.

**THRUST BEARING**—A bearing that limits the end play and absorbs the axial thrust of a shaft.

**TOP OFF**—To fill up a tankA ship tops off its tanks with fuel oil before leaving port.

**TORQUE**—The force that produces or tends to produce rotation.

**TOUGHNESS**—The property of a material that enables it to withstand shock as well as to be deformed without breaking.

**TRANSFORMER**—An electrical device used to step up or step down an ac voltage.

**TRICK WHEEL**—A steering wheel in the steering engine room or emergency steering station of a ship.

**TUBE EXPANDER**—A tool that expands replacement tubes into their seats in boiler drums and headers.

**TURBINE**—A multibladed rotor driven by steam, hot gas, or water.

**TURBINE STAGE**—One set of nozzles and the succeeding row or rows of moving blades.

**TURBINE TURNING GEAR**—A motor-driven gear arrangement that slowly rotates idle propulsion shafts, reduction gears, and turbines.

**UPTAKES (EXHAUST TRUNKS)**—Large enclosed passages that direct the flow of exhaust gases to the stacks.

**VACUUM**—A space that has less than atmospheric pressure in it.

**VENT**—A valve in a tank or compartment that primarily permits air to escape.

**VISCOSITY**—A liquids resistance to flow.

**VOID**—An empty, watertight compartment separating other compartments.

**VOLATILE**—The term that describes a liquid that vaporizes quickly.

**VOLTAGE**—Electric potential (emf).

**VOLTAGE TESTER**—A portable instrument that detects electricity.

**WATER TUBE BOILER**—Boilers in which the water flows through the tubes and is heated by the gases of combustion.

**WATER WASHING**—A method of cleaning to remove contaminants.

**WELDING LEAD**—The conductor through which electrical current is transmitted from the power source to the electrode holder and welding rod.

**WIPE BEARINGS**—A bearing in which the babbitt has melted because of excess heat.

**WIREWAYS**—Passageways between decks and on the overheads of compartments that contain electric cables.

**WORK REQUEST**—Request issued to a naval shipyard, tender, or repair ship for repairs.

**ZERK FITTING**—A small fitting that can be applied to a grease gun to force lubricating grease into bearings or moving parts of machinery.

**ZINC**—A cheap, renewable metal placed in saltwater systems so that electrolysis will act upon the zinc rather than the ship's structure.

## APPENDIX II

# REFERENCES

### Chapter 1

*Fireman*, NAVEDTRA 10520-H, Naval Education and Training Program Development Center, Pensacola, Florida, 1987.

*Standard Organization and Regulations of the U.S. Navy*, OPNAVINST 3120.32B, Department of the Navy, Office of the Chief of Naval Operations, Washington, D.C., 1986.

### Chapter 2

*Fireman*, NAVEDTRA 10520-H, Naval Education and Training Program Development Center, Pensacola, Florida, 1987.

*Hull Maintenance Technician 3 & 2*, Vol. 1, NAVEDTRA 10571-1, Naval Education and Training Program Development Center, Pensacola, Florida, 1984.

### Chapter 3

*Fireman*, NAVEDTRA 10520-H, Naval Education and Training Program Development Center, Pensacola, Florida, 1987.

### Chapter 4

*Fireman*, NAVEDTRA 10520-H, Naval Education and Training Program Development Center, Pensacola, Florida, 1987.

*Naval Ships' Technical Manual*, S9086-HY-STM-000, Chapter 254, "Condensers, Heat Exchangers, and Air Ejectors," Naval Sea Systems Command, Washington, D.C., 1979.

### Chapter 5

*Fireman*, NAVEDTRA 10520-H, Naval Education and Training Program Development Center, Pensacola, Florida, 1987.

*Naval Ships' Technical Manual*, S9086-GY-STM-008, Chapter 221, "Boilers," Naval Sea Systems Command, Washington, D. C., 1977.

### Chapter 6

*Naval Ships' Technical Manual*, S9086-G9-STM-000, Chapter 231, "Propulsion Turbine (Steam)," Naval Sea Systems Command, Washington, D. C., 1982.

*Naval Ships' Technical Manual*, S9086-HY-STM-000, Chapter 254, "Condensers, Heat Exchangers, and Air Ejectors," Naval Sea Systems Command, Washington, D.C., 1979.

*Fireman*, NAVEDTRA 10520-H, Naval Education and Training Program Development Center, Pensacola, Florida, 1987.

## **Chapter 7**

*Fireman*, NAVEDTRA 10520-H, Naval Education and Training Program Development Center, Pensacola, Florida, 1987.

## **Chapter 8**

*Fireman*, NAVEDTRA 10520-H, Naval Education and Training Program Development Center, Pensacola, Florida, 1987.

*Naval Ships' Technical Manual*, S9086-H7-STM-000, Chapter 262, "Lubricating Oil, Greases, Hydraulic Fluids, and Lubrication Systems," Naval Sea Systems Command, Washington, D.C., 1983.

*Naval Ships' Technical Manual*, S9086-SN-STM-000, Chapter 541, "Petroleum Fuel, Storage, Use and Testing," Naval Sea Systems Command, Washington, D.C., 1982.

## **Chapter 9**

*Fireman*, NAVEDTRA 10520-H, Naval Education and Training Program Development Center, Pensacola, Florida, 1987.

*Naval Ships' Technical Manual*, S9086-RH-STM-000, Chapter 503, "Pumps," Naval Sea Systems Command, Washington, D.C., 1981.

## **Chapter 10**

*Fireman*, NAVEDTRA 10520-H, Naval Education and Training Program Development Center, Pensacola, Florida, 1987.

*Naval Ships' Technical Manual*, S9086-RH-STM-000, Chapter 503, "Pumps," Naval Sea Systems Command, Washington, D. C., 1981.

*Naval Ships' Technical Manual*, 0901-LP-480-0001, Chapter 9480, "Piping Systems," Naval Sea Systems Command, Washington, D.C., 1973.

## **Chapter 11**

*Fireman*, NAVEDTRA 10520-H, Naval Education and Training Program Development Center, Pensacola, Florida, 1987.

*Standard Organization and Regulations of the U.S. Navy*, OPNAVINST 3120.32B, Department of the Navy, Office of the Chief of Naval Operations, Washington, D.C., 1986.

*Navy Occupational Safety and Health (NAVOSH) Program*, OPNAVINST 5100.23B, Department of the Navy, Office of the Chief of Naval Operations, Washington, D. C., 1983.

## **Chapter 12**

*Fireman*, NAVEDTRA 10520-H, Naval Education and Training Program Development Center, Pensacola, Florida, 1987.



*Naval Ships' Technical Manual, S9086-H7-STM-000, Chapter 262, "Lubricating Oil, Greases, Hydraulic Fluids, and Lubrication Systems," Naval Sea Systems Command, Washington, D C., 1983.*

*Naval Ships Technical Manual, S9086-RJ-STM-000, Chapter 504, "Pressure, Temperature, and Other Mechanical and Electromechanical Measuring Instruments," Naval Sea Systems Command, Washington, D.C., 1980.*

### Chapter 13

*Fireman, NAVEDTRA 10520-H, Naval Education and Training Program Development Center, Pensacola, Florida, 1987.*



# INDEX

## A

- AC generators, 12-2
- Accessories, 10-9 to 10-12
  - dehydrator, 10-9
  - evaporator pressure regulating valve, 10-10
  - high-pressure cutout switch, 10-11
  - low-pressure cutout switch, 10-10
  - moisture indicator, 10-9
  - pressure gauges and thermometers, 10-12
  - solenoid valve and thermostatic control switch, 10-9
  - strainer, 10-11
  - water failure switch, 10-11
  - water regulating valve, 10-11
- Air compressors, 10-24 to 10-31
  - classification of, 10-25
  - high-pressure, 10-29
  - low-pressure (ship's service), 10-25
  - safely precautions, 10-31
- Air conditioning, 10-13 to 10-17
  - air motion, 10-16
  - body heat, 10-15
  - comfort, 10-17
  - heat of air, 10-14
- Ammeters, 11-10
- Anchor windlasses, 10-43
- Asbestos pollution and control, 13-4
- Atoms, 2-2
- Auxiliary boiler, 4-15
- Auxiliary machinery and equipment, 10-1 to 10-54
  - air compressors, 10-24
  - air conditioning, 10-13
  - characteristics of, 10-12
  - dehydrators, 10-31

## Auxiliary machinery and equipment-Continued

- distilling plants, 10-34
- electrohydraulic drive machinery, 10-40
- galley and laundry equipment, 10-50
- lubricating systems, 10-48
- mechanical cooling equipment, 10-19
- purifiers, 10-35
- refrigeration, 10-1
- ventilation equipment, 10-17

## Auxiliary steam system, 3-5

## B

- Basic gas turbine engine theory, 6-3
  - operating principles, 6-3
  - theoretical cycles, 6-5
- Basic steam cycle, 3-1 to 3-6
  - auxiliary steam system, 3-5
  - main steam system, 3-1
- Batteries, 12-12
- Battle lanterns, 12-12
- Bellows gauge, 11-4
- Body heat balance, 10-45
- Boilers, 4-1 to 4-15
  - auxiliary, 4-15
  - classification, 4-2
  - components, 4-4
  - terminology, 4-15
  - waste-heat, 4-15
- Boilers, classification of, 4-2
  - steam and water spaces, arrangement of, 4-3
  - burner location, 4-4
  - superheat, control of, 4-4
  - furnace pressure, 4-4
  - intended service, 4-2

Boilers, classification of—Continued  
    fire and water spaces, location of, 4-3  
    operating pressure, 4-4  
    circulation, types of, 4-3  
    superheaters, types of, 4-4

Boilers, components of, 4-4  
    downcomer tubes, 4-6  
    furnace, 4-11  
    generating tubes, 4-6  
    internal fittings, 4-7  
    steam drum, 4-5  
    water drum, 4-6

Bourdon-tube gauges, 11-1  
    vacuum, compound, and differential, 11-2  
    duplex, 11-2  
    simplex, 11-2

Burner location, 4-4

Burnerman, 1-20

**C**

Capstans, 10-44

Central control console, 6-19

Centrifugal compressor, 6-6

Centrifugal fans, 10-17

Centrifugal pumps, 9-1

Checkman/upper-level watch, 1-20

Chilled water circulating systems, 10-19  
    fan-coil assemblies, 10-24  
    lithium bromide absorption unit, 10-22  
    vapor compression units, 10-20

Clutches and reverse gears, 8-4  
    airflex clutch and gear assembly, 8-7  
    hydraulic clutches or couplings, 8-7  
    twin-disk clutch and gear mechanism, 8-7

Cold-iron watch, 1-20

Constant-pressure pump governors, 9-12

Contact level sensors, 11-12

Converting power to drive, 8-3  
    reduction gears, 8-3

Cooling system, 7-11

Cranes, 10-46

## **D**

Damage control central watch, 1-19

DC generators and exciters, 12-2

Dehydrators, 10-31 to 10-34

    type I, 10-32

    type II, 10-33

    type III, 10-33

Diaphragm gauges, 11-4

Diesel-driven generators, 12-5

Diesel gear drive, 8-2

Distilling plants, 10-34

Downcomer tubes, 4-6

## **E**

Electrical indicating instruments, 11-9

    ammeters, 11-10

    contact level sensors, 11-12

    frequency meters, 11-10

    kilowatt meters, 11-10

    liquid-level indicators, 11-11

    phase-sequence indicators, 11-11

    synchrosopes, 11-11

    tank level indicators, 11-12

    voltmeters, 11-9

Electrical temperature measuring devices, 11-7

    resistance temperature detectors, 11-8

    resistance temperature elements, 11-7

Electric current, 12-1

Electric motors, 12-10

Electricity, 2-3, 12-1

Electrohydraulic drive machinery, 10-40 to 10-48

    anchor windlasses, 10-43

Electrohydraulic drive machinery—Continued

- capstans, 10-44
- cranes, 10-46
- elevators, 10-47, 10-48
- speed gear, 10-40
- steering gear, 10-40
- winches, 10-44

Electrohydraulic elevators, 10-47

Electrohydraulic speed gear, 10-40

Electrohydraulic steering gear, 10-40

- power unit, 10-41
- ram unit, 10-41

Electrohydraulic elevators, 10-47

Electromechanical elevators, 10-48

Electromotive force, 12-1

Elements and compounds, 2-1

Engine construction, 6-9

- accessories, 6-14
- combustion chambers, 6-11
- compressor, 6-11
- turbines, 6-12

Energy, 2-6 to 2-14

- energy transformations, 2-9
- mechanical, 2-7
- thermal, 2-8

Energy transformations, 2-9

- combustion, 2-12
- conservation of energy, 2-9
- sensible heat and latent heat, 2-12
- transformation of heat to work, 2-10
- units of heat measurement, 2-12
- steam, 2-11

Engineering administration , 1-1 to 1-23

- engineering department, 1-1
- engineering department ratings, 1-6
- EOSS 1-12

Engineering administration—Continued

- safety program, 1-8
- tag-out program, 1-10
- 3-M systems, 1-9
- watch standing, 1-18
- watch, quarter, and station bills, 1-23

Engineering department organization, 1-1

- engineer officer, 1-1
- enlisted personnel, 1-5

Engineering department ratings, 1-6

- marine engineering occupational field, 1-6
- ship maintenance occupational field, 1-7

Engineering fundamentals, 2-1 to 2-20

- energy, 2-6
- hydraulics, principles of, 2-17
- magnetism, 2-3
- mass, weight, force, and inertia, 2-6
- matter, 2-1
- metal, 2-17
- pneumatics, principles of, 2-18
- pressure, 2-15
- speed, velocity, and acceleration, 2-5
- temperature, 2-1

Engineering officer of the watch, 1-19

Engineer officer, 1-1

- assistants, 1-2
- division officer, 1-4

Engine room lower-level watch, 1-21

Engine room upper-level watch, 1-21

Engine strokes, basic, 7-3

- compression ignition system, 7-8
- cooling system, 7-10
- fuel system, 7-9
- lubrication system, 7-10
- starting systems, 7-10

- Engine strokes, basic–Continued
  - valve mechanism, 7-7
- Enlisted personnel, 1-5
  - oil and water king, 1-5
  - small boat engineer, 1-6
- Environmental controls, 13-1 to 13-7
  - heat stress, 13-1
  - pollution, 13-3
  - refrigerants, 13-5
  - sewage System, 13-6
- Exhausts, 10-18
- F**
- Fasteners, 9-45 to 9-47
  - locknuts, 9-45
  - lockwashers, 9-47
  - threaded locking devices, 9-45
- Filter/strainer location, 9-28
- Filter/strainer materials, 9-29
- Filters and strainers, 9-26 to 9-32
  - construction of, 9-29
  - location of, 9-28
  - materials, 9-29
  - maintenance of, 9-32
  - mesh and micron ratings, 9-27
  - types of, 9-30
- Fire and water spaces, location of, 4-3
- Fittings, 9-37
  - bolted flange joints, 9-37
  - flared fittings, 9-39
  - flareless fittings, 9-39
  - silver-brazed joints, 9-38
  - threaded joints, 9-37
  - unions, 9-38
  - welded joints, 9-38
- Fixed joints, packing of, 9-43
- Flange safety shields, 9-40
- Flexible hose assemblies, 9-33
  - air test, 9-35
  - configurations of, 9-33
  - fitting identification, 9-34
  - hose identification, 9-34
  - hydrostatic test, 9-35
  - installation of, 9-35
  - inspection by ship's force of, 9-36
  - service life of rubber hose, 9-37
  - servicing, 9-37
  - shelf life, 9-37
  - storage, 9-37
  - visual inspection of, 9-34
- Frequency meters, 11-10
- Fuel system, 7-9
- Furnace, 4-11
  - combustion air, 4-13
  - fire, 4-14
- G**
- Galley and laundry equipment, 10-50 to 10-54
  - galley equipment, 10-50
  - laundry equipment, 10-54
- Galley equipment, 10-50
- Gasoline engines, 7-13
- Gas turbines, 6-1 to 6-20
  - advantages and disadvantages of, 6-19
  - American development, 6-2
  - basic engine theory, 6-3
  - types and construction of, 6-6
  - operation of, 6-15
  - history and background, 6-1
  - marine gas turbines, 6-2
  - twentieth-century development, 6-2
- Gas turbine drive, 8-3
- Gas turbine engine, types and construction of, 6-6
  - axial-flow compression, 6-7

Continued

centrifugal compressor, 6-6

classification by power usage, 6-9

engine construction, 6-19

Gas turbine operation, 6-15

central control console, 6-19

console operation overview, 6-19

general description of, 6-16

local control console, 6-17

ship control console, 6-19

Generating tubes, 4-6

Generator and distribution system, 12-7

Generator types and drives, 12-1

ac generators, 12-2

dc generators and exciters, 12-2

diesel-driven generators, 12-5

motor generators, 12-5

ship's service turbine-driven generators, 12-3

static frequency changers, 12-7

**H**

Halocarbons, 10-12

Heat cramps, 13-1

Heat exhaustion, 13-1

Heat stress, 13-1

Heatstroke, 13-1

Hydraulics, principles of, 2-17

**I**

Inspections and maintenance, 9-22, 9-25, 9-32, 9-34, 9-36

Instruments, 11-1 to 11-15

electrical indicating, 11-9

pressure gauges, 11-1

revolution counters and indicators, 11-13

salinity indicators, 11-14

temperature measuring devices, 11-5

Instruments-Continued

torque wrenches, 11-14

Insulation, 9-47

Internal-combustion engines, 7-1 to 7-14

basic engine strokes, 7-3

development of power, 7-3

gasoline engines, 7-13

gasoline versus diesel engines, 7-1

reciprocating engines, 7-1

Internal-combustion engine, starting systems of, 7-11

air-starting, 7-12

electronic, 7-12

hydraulic, 7-12

**K**

Kilowatt meters, 11-10

**L**

Laundry equipment, 10-54

Lighting distribution systems, 12-14

Liquid-level indicators, 11-11

Local control console, 6-17

Locknuts, 9-45

Lockwashers, 9-47

Lubricating systems, 10-48 to 10-50, 7-11

functions of, 10-49

lubricating oils and greases, 10-49

**M**

Magnetism, 2-1 to 2-3

electricity, 2-3

Ohm's law, 2-4

Main steam system, 3-1

condensation, 3-4

expansion, 3-4

feed, 34

generation, 3-1

Manometers, 11-5  
 Marine gas turbines, 6-2  
 Mass, weight, force, and inertia, 2-6  
 Matter, 2-1 to 2-3  
     atoms, 2-2  
     elements and compounds, 2-1  
     molecules, 2-1  
 Mechanical cooling equipment, 10-19 to 10-24  
     chilled water circulating systems, 10-19  
     self-contained air conditioners, 10-24  
 Mechanical energy, 2-7  
 Mechanical refrigeration systems, 10-1  
 Mesh and micron ratings, 9-27  
 Messenger of the watch, 1-19  
 Metals, 2-19  
 Molecules, 2-1  
 Motor controllers, 12-11  
 Motor generators, 11-5  
 Moving joints, packing of, 9-41  
  
**N**  
  
 Noise pollution, 13-4  
  
**O**  
  
 Ohm's law, 2-4  
 Oil and chemical pollution, 13-3  
     oil spill prevention, 13-3  
     oil spill removal, 13-4  
 O-rings, 9-44  
  
 Packing and gasket material, 9-41 to 9-45  
 Packing and gasket selection, 9-41  
 Packing and gasket material, 9-41  
     selection of, 9-41  
     fixed joints, 9-43  
     moving joints, 9-41  
  
 Phase-sequence indicators, 11-11  
 Piping, 9-32 to 9-41  
     fittings, 9-37  
     flange safety shields, 9-40  
     flexible hose assemblies, 9-33  
     identification of, 9-32,9-40  
     inspections and maintenance of, 9-40  
     materials of, 9-32  
     O-rings, 9-44  
     pipe hangers, 9-40  
 Pipe hangers, 9-40  
 Piping identification marking, 9-32  
 Piping, materials, 9-32  
 Pneumatics, principles of, 2-18  
 Pollution, 13-3  
     asbestos pollution and control, 13-4  
     noise pollution and control, 13-4  
     oil and chemical pollution, 13-3  
 Portable fans, 10-19  
 Portable electric equipment, 12-12  
     battle lanterns, 12-12  
     sealed-beam lights, 12-13  
 Power, development of, 7-3  
 Power distribution systems, 12-14  
 Pressure, definitions of, 2-15  
 Pressure gauges, 11-1  
     bellows gauge, 11-4  
     Bourdon-tube gauges, 11-1  
     diaphragm gauges, 11-4  
     manometers, 11-5  
 Propeller, 8-8  
 Propeller indicators, 11-13  
 Propulsion units, 8-1  
     diesel gear drive, 8-1  
     gas turbine drive, 8-2  
     steam turbine gear drive, 8-2



- Pumps, 9-1 to 9-12
  - alignment of shaft and coupling, 9-10
  - classification of, 9-10
  - centrifugal pumps, 9-1
  - jet pumps, 9-10
  - rotary pumps, 9-7
- Pumps, valves, and piping, 9-1 to 9-49
  - constant-pressure pump governors, 9-12
  - fasteners, 9-45
  - filters and strainers, 9-26
  - insulation, 9-47
  - packing and gasket material, 9-41
  - piping, 9-32
  - pumps, 9-1
  - steam traps, 9-25
  - valves, 9-13
- Purifiers, 10-35 to 10-40
  - operation of, 10-36, 10-38
  - types of, 10-37
- Pyrometers, 11-7
- R**
- Reciprocating engines, 7-1
- Reduction gears, 8-3
- R-12 system, 10-3
  - capacity control system, 10-6
  - compressor, 10-5
  - condenser, 10-8
  - evaporator, 10-5
  - receiver, 10-8
  - thermostatic expansion valve (TXV), 10-3
- Refrigerants, 10-12, 13-5
  - halocarbons, 10-12
  - cylinders, handling of, 10-13
  - safety, 10-13
- Refrigeration, 10-1 to 10-12
  - accessories, 10-9
- Refrigeration-Continued
  - fundamentals of, 10-1
  - mechanical systems, 10-1
  - refrigeration ton, 10-1
  - R-12 system, 10-3
  - Refrigeration air dehydrator (type I), 10-32
  - Refrigeration and desiccant air dehydrator (type III), 10-33
  - Refrigeration ton, 10-1
  - Resistance, 12-1
  - Revolution counters and indicators, 11-13
- S**
- Safety Program, 1-8
- Salinity indicators, 11-11
- Self-contained air conditioners, 10-24
- Sealed-beam lights, 12-13
- Sewage system, 13-6
- Shaft alley watch, 1-22
- Shaft and coupling, alignment of, 9-10
- Ship control console, 6-19
- Shipboard electrical equipment, 12-1 to 12-13
  - batteries, 12-12
  - electric motors, 12-10
  - electrical safety precautions, 12-14
  - generator and distribution system, 12-7
  - generator types and drives, 12-1
  - introduction to, 12-1
  - motor controllers, 12-11
  - portable electric equipment, 12-12
  - shipboard electrical systems and connections, 12-15
  - shipboard power distribution, 12-7
- Shipboard electrical systems and connections, 12-14
- Shipboard power distribution, 12-7
- Ship maintenance occupational field, 1-7
- Ships' Maintenance and Material Management (3-M) Systems, 1-9

Shore power connections, 12-14  
Ship propulsion, 8-1 to 8-8

- converting power to drive, 8-1
- principles of, 8-1
- propulsion units, 8-3

Ship propulsion, principles of, 8-1  
Ship's service turbine-driven generators, 12-3  
Sounding and security, 1-19  
Speed, velocity, and acceleration, 2-5  
Standard ship organization, 1-1  
Static frequency changers, 12-7  
Steam and water spaces, arrangement of, 4-3  
Steam drum, 4-5  
Steam traps, 9-25  
Steam turbines, 5-1 to 5-7

- classification of, 54
- theory of, 5-1

Steam turbine gear drive, 8-2  
Switchboard, components of, 12-7  
Superheat, control of, 4-4  
Synchrosopes, 11-11

## T

Tags, types of, 1-11

- caution tag, 1-11
- danger tag, 1-11
- out-of-commission labels, 1-11
- out-of-calibration labels, 1-12

Tank level indicators, 11-12  
Temperature, 2-1, 10-14  
Temperature-measuring devices, 11-5

- thermometers (mechanical), 11-5
  - electrical, 11-17
  - filled-system thermometers, 11-6
  - pyrometers, 11-7

Thermometers (mechanical), 11-5

- bimetallic expansion thermometers, 11-6

Thermometers (mechanical)-Continued

- liquid-in-glass thermometers, 11-5
- filled system, 11-6

Thermal energy, 2-8  
Threaded locking devices, 9-45  
Throttle watch, 1-21  
Torque wrenches, 11-14  
Tube-axial fans, 10-17  
Turbines, construction of, 5-4

- bearings, 5-6
- casings, 5-5
- foundations, 5-5
- nozzles, 5-6
- rotors, 5-6
- shaft packing glands, 5-6

Turbine theory, 5-1

- impulse principle, 5-2
- reaction principle, 5-2

## V

Valve construction, 9-13  
Valve handwheel identification and color coding, 9-21  
Valve manifolds, 9-21  
Valves, types of, 9-13

- check valves, 9-16
- special-purpose valves, 9-16
- stop valves, 9-13

Valves, 9-13 to 9-25

- construction of, 9-1
- handwheel identification and color coding of, 9-21
- maintenance of, 9-22
- manifolds of, 9-21
- types of, 9-13

Vane-axial fans, 10-17  
Ventilation equipment, 10-17 to 10-24  
Voltmeters, 11-9

**W**

Waste-heat boilers, 4-15

Watch, quarter, and station bills, 1-23

Watch-standing duties and responsibilities, 1-18 to 1-23

burnerman, 1-20

checkman/upper level watch, 1-20

cold-iron watch, 1-20

damage control central watch, 1-19

engineering officer of the watch, 1-19

engine room lower-level watch, 1-21

Watch-standing duties and responsibilities-Continued

engine room upper-level watch, 1-21

evaporator watch, 1-23

fireroom lower-level, 1-20

messenger of the watch, 1-19

shaft alley watch, 1-22

sounding and security, 1-19

throttle watch, 1-21

Watt, 12-1

Winches, 10-44



---

---

# *Assignment Questions*

---

---

**Information:** The text pages that you are to study are provided at the beginning of the assignment questions.



# A S S I G N M E N T    1

Textbook Assignment: "Engineering Administration," Chapter 1, pages 1-2 through 1-23.

---

IN ANSWERING QUESTIONS 1-1 THROUGH 1-7, SELECT FROM COLUMN B THE ENGINEERING DEPARTMENT OFFICERS RESPONSIBLE FOR THE DUTIES IN COLUMN A. RESPONSES FROM COLUMN B MAY BE USED MORE THAN ONE TIME.

<u>A. DUTIES</u>	<u>B. OFFICERS</u>
1-1. Directs the division through work center supervisors	1. Engineer officer 2. Training officer
1-2. Responsible for the completion of all repairs within the capacity of the shops in the engineering department	3. Electrical officer 4. Division officer
1-3. Administers and executes the ship's electrical safety program	
1-4. Responsible for developing a department training program in support of the training objectives of the ship	
1-5. Responsible for the operation, care, and maintenance of all propulsion and auxiliary machinery	
1-6. Maintains the department's training records and training reports	
1-7. Assigns watches and duties within the division	

1-8. The three main assistants to the engineer officer are the main propulsion assistant, the electrical officer, and the

1. damage control assistant
2. training officer
3. division chief petty officer
4. small boat engineer

1-9. Which of the following personnel is responsible for screening the engineering department's incoming correspondence and initiating the required action?

1. The administrative assistant
2. The training officer
3. The damage control assistant
4. The division chief petty officer

1-10. A list of all Navy schools and their requirements can be found in which of the following publication?

1. NSTM, chapter 541
2. NAVEDTRA 10120-J
3. NAVEDTRA 10500
4. NAVEDTRA 10054-F

1-11. The duties and responsibilities of the gas-free engineer are described in what chapter of the Naval Ships' Technical Manual?

1. 221
2. 074
3. 262
4. 504

1-12. What division operates the boilers and fireroom auxiliary machinery?

1. B division
2. M division
3. E division
4. R division

- 1-13. What division is responsible for keeping the ship watertight?
1. A division
  2. B division
  3. M division
  4. R division
- 1-14. On steam-driven ships, the oil and water king is either a BT or a/an
1. ML
  2. MM
  3. EM
  4. IC
- 1-15. What instruction describes the 3-M Systems in detail?
1. OPNAVINST 5100.20-C
  2. SECNAVINST 5215.1C
  3. OPNAVINST 3120.32B
  4. OPNAVINST 4790.4
- 1-16. What rating is responsible for making wooden, plastic, plaster, and metal patterns?
1. MR
  2. IM
  3. OM
  4. PM
- 1-17. What is OPNAVINST 5100.19?
1. The 3-M Manual
  2. The SORM
  3. The NSTM
  4. Navy Safety Precautions for Forces Afloat
- 1-18. Firemen, Enginemen, or Machinist's Mates are detailed as boat engineers from what division?
1. B division
  2. A division
  3. M division
  4. R division
- 1-19. Which of the following ratings is responsible for operating, maintaining, and repairing reciprocating engines?
1. EN
  2. IC
  3. MR
  4. OM
- 1-20. What officer is responsible for the safety of the entire command?
1. The engineering officer of the watch
  2. The engineer officer
  3. The executive officer
  4. The commanding officer
- 1-21. DANGER tags are what color?
1. Orange
  2. Black
  3. Red
  4. Yellow
- 1-22. CAUTION tags are what color?
1. Green
  2. Yellow
  3. Red
  4. Purple
- 1-23. OUT-OF-CALIBRATION labels are what color?
1. Orange
  2. Red
  3. Yellow
  4. Brown
- 1-24. OUT-OF-COMMISSION labels are what color?
1. Orange
  2. Yellow
  3. White
  4. Red
- 1-25. When a Ship is in port, an audit of the tag-out log should be conducted by the EDO at least how often?
1. Every week
  2. Every 2 weeks
  3. Every 3 weeks
  4. Every month



- 1-26. When a ship is in the yards, an audit of the tag-out log should be conducted by the EDO at least how often?
1. Every week
  2. Every 2 weeks
  3. Every 3 weeks
  4. Every month
- 1-27. The EOSS was developed by which of the following commands?
1. OPNAV
  2. NMPC
  3. NAVSEA
  4. CNET
- 1-28. The EOSS involves the participation of which of the following personnel?
1. Department heads only
  2. Watch standers only
  3. Enginemen only
  4. All personnel from the department head to the watch stander
- 1-29. The EOSS was designed for which of the following purposes?
1. To improve the operational readiness of the ship's engineering plant
  2. To increase operational efficiency and provide better engineering plant control
  3. To reduce operational casualties and extend equipment life
  4. All of the above
- 1-30. The EOSS is composed of which of the following parts?
1. The User's Guide
  2. The engineering operational procedures
  3. The engineering operational casualty control
  4. All of the above
- 1-31. The administrative organization for all types of ships is prescribed in which of the following instruction?
1. OPNAVINST 5100.23B
  2. OPNAVINST 3120.32B
  3. OPNAVINST 4790.4B
  4. SECNAVINST 5216.5C
- 1-32. The ultimate responsibility for organization of the officers and crew of a ship belongs to which of the following officers?
1. The administrative officer
  2. The engineer officer
  3. The executive officer
  4. The commanding officer
- 1-33. Which of the following ratings is responsible for operating, maintaining, and repairing gyrocompasses, alarms, and voice interior communication systems?
1. EM
  2. EN
  3. IC
  4. IM
- 1-34. The GS rating is divided into how many groups?
1. One
  2. Two
  3. Three
  4. Four
- 1-35. Which of the following ratings is responsible for performing preventive and corrective maintenance on Navy timepieces?
1. IM
  2. IC
  3. EM
  4. OM

---

IN ANSWERING QUESTIONS 1-36 THROUGH 1-42, SELECT FROM COLUMN B THE PERSONNEL RESPONSIBLE FOR THE DUTIES IN COLUMN A. RESPONSES FROM COLUMN B MAY BE USED MORE THAN ONE TIME.

<u>A. DUTIES</u>	<u>B. PERSONNEL RESPONSIBLE</u>
1-36. Assists the division officer in coordinating and administering the division	1. Damage control assistant 2. Administrative assistant 3. Main propulsion assistant 4. Division CPO
1-37. Functions as an aid to the engineer officer in the details of administration	
1-38. Responsible for control of the ship's stability, list, and trim	
1-39. In charge of the A and R division shops	
1-40. Responsible for the preparation and care of the Engineering Log and Engineer's Bell Book	
1-41. Responsible for the care, stowage, and use of fuels and lubricating oils	
1-42. Supervises the maintenance of department records and maintains a tickler file on all required reports	

---

- 1-43. The planned maintenance system was established for which of the following purposes?
1. To describe the methods and tools to be used on a job
  2. To plan and schedule maintenance tasks
  3. To estimate and evaluate material readiness
  4. All of the above
- 1-44. What is the primary objective of the Ships' 3-M Systems?
1. To provide for managing maintenance and maintenance support in a way to ensure maximum equipment operational readiness
  2. To ensure that hazardous conditions do not exist in a working area
  3. To ensure 100% availability of all shipboard systems
  4. To ensure that all ships are properly manned with the appropriate ratings
- 1-45. The use of DANGER or CAUTION tags is NOT a substitute for other safety measures, such as locking valves or pulling fuses.
1. True
  2. False
- 1-46. Normally, which of the following personnel fills out and signs the record sheet and prepares the tags?
1. The commanding officer
  2. The executive officer
  3. The petty officer in charge of the work
  4. The engineer officer
- 1-47. What type of tag or label is used to prohibit the operation of equipment that could jeopardize the safety of personnel or endanger equipment?
1. A red DANGER tag
  2. A yellow CAUTION tag
  3. An OUT-OF-CALIBRATION label
  4. An OUT-OF-COMMISSION label

1-48. As a Fireman, you will NOT be required to stand watches in engineering spaces.

1. True
2. False

1-49. Which of the following watches is in charge of the main propulsion plant and associated auxiliaries?

1. The throttle watch
2. The EOWW
3. The DCC watch
4. The cold-iron watch

1-50. A burnerman is responsible for all EXCEPT which of the following duties?

1. Cutting burners in and out as directed by the BTOW
2. Changing atomizers when authorized by the BTOW
3. Lighting fires or cutting in additional burners
4. Changing the speed of the ship's propellers

1-51. Which of the following watches constantly checks the pressures, temperatures, vacuum, and salt content of the distilled water aboard the ship?

1. The evaporator watch
2. The shaft alley watch
3. The cold-iron watch
4. The messenger of the watch

1-52. Who is responsible for preparing the watch, quarter, and station bill for a division?

1. The commanding officer
2. The executive officer
3. The command duty officer
4. The division officer

---

IN ANSWERING QUESTIONS 1-53 THROUGH 1-58, SELECT FROM COLUMN B THE ENGINEERING WATCHES RESPONSIBLE FOR THE DUTIES IN COLUMN A. RESPONSES FROM COLUMN B MAY BE USED MORE THAN ONE TIME.

<u>A. DUTIES</u>	<u>B. ENGINEERING WATCHES</u>
1-53. Checks all sea valves after working hours when the ship is in dry dock	1. Throttle watch 2. Sounding and security watch 3. Messenger of the watch
1-54. Usually assigned as the sound-powered telephone talker when the ship is undergoing close maneuvering conditions with other ships, entering or leaving port, or refueling or replenishing from another ship	4. Cold-iron watch
1-55. Functions as the ship's first line of defense in maintaining watertight integrity while on watch	
1-56. Complies with orders from the bridge concerning the movement of the ship's propellers	
1-57. Primary mission is to look for fire and flooding hazards	
1-58. Ensures that weights, such as fuel oil or feedwater, are NOT shifted without permission of the engineer officer or DCA	

---

1-59. Which of the following publications will provide you with information about the watch, quarter, and station bill?

1. Naval Ships' Technical Manual, chapter 541
2. Catalog of Training Courses
3. Basic Military Requirements
4. The Advancement Handbook for Petty Officers

1-60. You will generally find which of the following information on the watch, quarter, and station bill?

1. Watch assignments for each person under various conditions of readiness
2. The station and job each person will have in emergency situations
3. A listing of each person as to billet number, locker number, bunk number, compartment number, name, rating, and rate
4. All of the above

## ASSIGNMENT 2

Textbook Assignment: "Engineering Fundamentals," chapter 2, pages 2-1 through 2-20, and "Basic Steam Cycle," chapter 3, pages 3-1 through 3-6.

---

- 2-1. Matter is defined as anything that occupies space and has
1. color
  2. weight
  3. motion
  4. electrical energy
- 2-2. Which of the following substances CANNOT be reduced to a simpler substance by chemical means?
1. An element
  2. A compound
  3. A gas
  4. A molecule
- 2-3. When two or more elements are chemically combined, what is the resulting substance called?
1. An atom
  2. A solid
  3. A mixture
  4. A compound
- 2-4. A combination of elements and compounds that are not chemically combined and can be separated by physical means is known as a
1. compound
  2. molecule
  3. mixture
  4. gas
- 2-5. A molecule is a chemical combination of which of the following parts?
1. Two or more atoms
  2. Two or more compounds
  3. A liquid and a solid
  4. An element and a compound
- 2-6. The smallest particle of an element that retains the characteristic of that element is known by what term?
1. A compound
  2. A molecule
  3. A mixture
  4. An atom
- 2-7. The electron and proton each have the same quantity of charge, although the mass of the proton is about how many times that of the electron?
1. 1028
  2. 1500
  3. 1837
  4. 3000
- 2-8. An atom of hydrogen, which contains one proton and one electron, has what atomic number?
1. One
  2. Two
  3. Three
  4. Four
- 2-9. Which of the following equipment use(s) magnetic tape?
1. Computers
  2. Tape recorders
  3. Video reproduction equipment
  4. All of the above
- 2-10. Electric motors use magnets to convert mechanical energy into what other type of energy?
1. Heat energy
  2. Solar energy
  3. Electrical energy
  4. Chemical energy

- 2-11. Which of the following materials is magnetic?
1. Cobalt
  2. Tin
  3. Glass
  4. Wood
- 2-12. On the Fahrenheit scale, what is the boiling point of pure water?
1. 32°F
  2. 100°F
  3. 102°F
  4. 212°F
- 2-13. On the Celsius scale, what is the freezing point of pure water?
1. 0°C
  2. 32°C
  3. 100°C
  4. 212°C
- 2-14. What Celsius temperature is equivalent to 212°F?
1. 32°C
  2. 100°C
  3. 180°C
  4. 212°C
- 2-15. On the Celsius scale, what is absolute zero?
1. -100°C
  2. -212°C
  3. -213°C
  4. -300°C
- 2-16. What type of pressure is actually shown on the dial of a gauge that registers pressure relative to atmospheric pressure?
1. Absolute pressure
  2. Barometric pressure
  3. Atmospheric pressure
  4. Gauge pressure
- 2-17. At sea level, what is the average atmospheric pressure in inches of mercury?
1. 29.92 in.Hg
  2. 30.00 in.Hg
  3. 39.92 in.Hg
  4. 40.12 in.Hg
- 2-18. What term is used to describe the actual atmospheric pressure that exists at any given moment?
1. Absolute pressure
  2. Positive pressure
  3. Gauge pressure
  4. Barometric pressure
- 2-19. Which of the following vacuum gauge readings would indicate a nearly perfect vacuum?
1. 28.92 in.Hg
  2. 29.92 in.Hg
  3. 30.00 in.Hg
  4. 31.92 in.Hg
- 2-20. What is absolute pressure?
1. Atmospheric pressure minus gauge pressure
  2. Atmospheric pressure plus gauge pressure
  3. Absolute pressure plus vacuum
  4. Gauge pressure plus vacuum
- 2-21. A gauge pressure of 300 psig equals approximately what absolute pressure?
1. 314.7 psia
  2. 324.7 psia
  3. 330.7 psia
  4. 344.7 psia
- 2-22. What term refers to the property of a metal that allows it to shatter easily?
1. Toughness
  2. Brittleness
  3. Strength
  4. Hardness

- 2-23. What term refers to the property of a metal that will NOT permit it to tear or shear easily?
1. Toughness
  2. Brittleness
  3. Strength
  4. Hardness
- 2-24. What term refers to the ability of a metal to stretch or bend without breaking?
1. Toughness
  2. Brittleness
  3. Strength
  4. Ductility
- 2-25. What term refers to the ability of a metal to maintain heavy loads without breaking?
1. Toughness
  2. Strength
  3. Hardness
  4. Ductility
- 2-26. What term refers to the property of a metal that allows it to be rolled, forged, hammered, or shaped without cracking or breaking?
1. Malleability
  2. Ductility
  3. Strength
  4. Toughness
- 2-27. Metals and alloys are divided into which of the following general classes?
1. Light and heavy
  2. Hard and soft
  3. Smooth and rough
  4. Ferrous and nonferrous
- 2-28. What are the two systems used by the Navy to identify metals?
1. The color marking system and the weight system
  2. The numbering system and the weight system
  3. The continuous identification marking system and the color marking system
  4. The continuous identification marking system and the weight system
- 2-29. Which of the following references contains information on the metals used aboard ship, their properties, and their identification systems?
1. NAVEDTRA 10571-1
  2. NAVEDTRA 12061
  3. NAVEDTRA 10792-E
  4. NAVEDTRA 10925
- 2-30. Electricity is a combination of a force called voltage and the movement of invisible particles known as
1. resistance
  2. friction
  3. mass
  4. current
- 2-31. In reference to current, which of the following statements is NOT true?
1. Current is the movement of invisible particles
  2. Current causes electrical devices to operate
  3. Current cannot be seen
  4. Current can flow out of a broken wire
- 2-32. Ohm's law is stated as  $I = E/R$ , What does I refer to?
1. Voltage in volts
  2. Current in amperes
  3. Resistance in ohms
  4. Pressure in pounds

- 2-33. Who is the formulator of the basic laws of modern philosophy concerning gravity and motion?
1. Sir Isaac Newton
  2. Blaise Pascal
  3. George Simon Ohm
  4. Jacques Bernoulli
- 2-34. What does Newton's third law state?
1. For every action there is an equal and opposite reaction
  2. An imbalance of force on a body tends to produce an acceleration in the direction of force
  3. A body in motion tends to remain in motion
  4. Work is done when an object is moved through a distance against a resisting force
- 2-35. What term refers to the rate at which velocity increases?
1. Speed
  2. Inertia
  3. Acceleration
  4. Potential energy
- 2-36. Frictional forces can cause which of the following problems?
1. Waste power
  2. Create heat
  3. Cause wear
  4. All of the above
- 2-37. Mechanical energy in transition is called
1. heat
  2. work
  3. motion
  4. potential energy
- 2-38. A sled that is being held at the top of an icy hill has what form of energy?
1. Mechanical potential energy
  2. Chemical energy
  3. Thermal energy
  4. Mechanical kinetic energy
- 2-39. Which of the following formulas is used to calculate work?
1.  $P E = W X D$
  2.  $I = E/R$
  3.  $W = F X D$
  4.  $F = W X D$
- 2-40. In reference to energy, which of the following statements is true?
1. Energy can be destroyed
  2. Energy can be created
  3. Energy can be transformed
  4. The total amount of energy input does not always equal the total amount of energy output
- 2-41. Steam hotter than the boiling temperature of water is known by which of the following terms?
1. Wet steam
  2. Superheated steam
  3. Saturated steam
  4. Latent heat of fusion
- 2-42. Thermal energy in transition is called
1. work
  2. motion
  3. potential energy
  4. heat
- 2-43. What does 32°F equal in Celsius?
1. 0°C
  2. 20°C
  3. 30°C
  4. 32°C
- 2-44. When the mercury level is at the +10° mark on the Celsius thermometer, it will be at what mark on the Fahrenheit thermometer?
1. +50°
  2. +20°
  3. +30°
  4. +40°



- 2-45. Whose law, simply stated, is interpreted as pressure exerted at any point upon an enclosed liquid is transmitted undiminished in all directions?
1. Charles's law
  2. Pascal's law
  3. Boyle's law
  4. Newton's law
- 2-46. What branch of mechanics deals with the mechanical properties of gases?
1. Hydraulics
  2. Thermal flow
  3. Pneumatics
  4. Mechanical potential energy
- 2-41. What are the four areas of operation in a main steam system?
1. Generation, expansion, condensation, and feed
  2. Expansion, condensation, power, and exhaust
  3. Generation, expansion, rotation, and feed
  4. Condensation, expansion, feed, and pressure
- 2-48. By the process of combustion in a boiler furnace, the chemical energy stored in the fuel oil is transformed into what other type of energy?
1. Mechanical energy
  2. Electrical energy
  3. Steam energy
  4. Thermal energy
- 2-49. In the basic steam cycle, when steam enters the turbines and expands, the thermal energy of the steam converts to what other type of energy?
1. Steam energy
  2. Mechanical energy
  3. Electrical energy
  4. Potential energy
- 2-50. The temperature at which a liquid boils under a given pressure is known by which of the following terms?
1. Saturation pressure
  2. Equilibrium contact
  3. Saturation temperature
  4. Critical point
- 2-51. The amount by which the temperature of superheated steam exceeds the temperature of saturated steam at the same pressure is known by which of the following terms?
1. Degree of saturated vapor
  2. Degree of superheat
  3. Degree of saturated pressure
  4. Degree of expansion
- 2-52. As the steam leaves or exhausts from the LP turbine, what system does it enter?
1. The auxiliary exhaust system
  2. The condensate system
  3. The HP turbine system
  4. The main steam system
- 2-53. The main condenser, the main condensate pump, the main air ejector condenser, and the top half of the DFT are components of what system?
1. The HP turbine system
  2. The LP turbine system
  3. The condensate system
  4. The auxiliary steam system
- 2-54. The main condenser receives steam from the
1. LP turbine
  2. HP turbine
  3. main feed pump
  4. economizer
- 2-55. The main feed pump receives the water (delivered from the booster pump) and discharges it into what system?
1. The condensate system
  2. The saturated steam system
  3. The auxiliary steam system
  4. The main feed piping system

- 2-56. The temperature at which a boiling liquid and its vapors may exist in equilibrium contact depends on which of the following factors?
1. The pressure under which the process takes place
  2. The time of day the process takes place
  3. The type of container used to hold the boiling liquid
  4. The percent of humidity in the air
- 2-57. Naval boilers produce which of the following types of steam?
1. Saturated steam
  2. Superheated steam
  3. Both 1 and 2 above
  4. Contaminated steam
- 2-58. The economizer is positioned on a boiler to perform what basic function?
1. It acts as a cooler
  2. It reverses the flow of water
  3. It acts as a preheater
  4. It converts the HP steam into LP steam
- 2-59. The expansion area of the main steam system is that part of the basic steam cycle in which steam from the boilers to the main turbines is
1. expanded
  2. cooled
  3. reversed in direction
  4. condensed
- 2-60. The DFT serves which of the following functions?
1. It removes dissolved oxygen and noncondensable gases from the condensate
  2. It preheats the water
  3. It acts as a reservoir to store feedwater to take care of fluctuations in feedwater demand or condensate supply
  4. All of the above

## ASSIGNMENT 3

Textbook Assignment: "Boilers," chapter 4, pages 4-1 through 4-15, and "Steam Turbines," chapter 5, pages 5-1 through 5-1.

---

- 3-1. What is the function of a boiler in the steam cycle?
1. To convert water into steam
  2. To convert steam into water
  3. To convert thermal energy into chemical energy
  4. To convert mechanical energy into thermal energy
- 3-2. Which of the following NSTM chapters contains information on boilers?
1. Chap 079
  2. Chap 090
  3. Chap 221
  4. Chap 554
- 3-3. What compartment contains the boilers, the station for firing or operating the boilers, and the main propulsion engines?
1. The boiler room
  2. The main machinery room
  3. The fireroom
  4. The boiler operating station
- 3-4. What term refers to the time during which the boilers have fires lighted until the fires are secured?
1. Steam drum pressure
  2. Design temperature
  3. Superheater outlet pressure
  4. Steaming hours
- 3-5. Boiler overload capacity is usually what percent of boiler full-power capacity?
1. 100%
  2. 110%
  3. 120%
  4. 130%
- 3-6. Which of the following terms refers to the actual temperature at the superheater outlet?
1. Design temperature
  2. Operating temperature
  3. Total heating surface temperature
  4. Economizer surface temperature
- 3-7. As far as boilers are concerned, what is the only distinction between a drum and a header?
1. Size
  2. Color
  3. Headers may be entered by a person
  4. Drums may not be entered by a person
- 3-8. Which of the following components can be found on boilers used onboard naval ships?
1. Steam and water drums
  2. Generating and circulating tubes
  3. Superheaters and economizers
  4. All of the above
- 3-9. During normal operation, the water in the steam drum is kept at approximately what level?
1. Full
  2. 1/2 full
  3. 1/3 full
  4. 1/4 full

- 3-10. In reference to the water drum, which of the following statements is accurate?
1. The water drum is the same size as the header
  2. The water drum is larger than the steam drum
  3. The water drum is smaller than the header
  4. The water drum is larger than the header
- 3-11. Downcomers range in diameter from 3 inches to
1. 9 inches
  2. 8 inches
  3. 6 inches
  4. 4 inches
- 3-12. Generating tubes are made of what type of metal?
1. Steel
  2. Copper
  3. Brass
  4. Tin
- 3-13. The surface blow pipe is used for which of the following purposes?
1. To remove suspended solid matter that floats on top of the water
  2. To lower the steam drum water level
  3. To blow water out to lower the chemical level in the boiler when it becomes too high
  4. All of the above
- 3-14. How many people are required during boiler light off?
1. One
  2. Two
  3. Three
  4. Four
- 3-15. In reference to boiler design pressure, which of the following statements is accurate?
1. Design pressure is the same as operating pressure
  2. Design pressure is lower than operating pressure
  3. Design pressure is not given in the manufacturer's technical manual for a particular boiler
  4. Design pressure is the maximum pressure specified by the boiler manufacturer as a criterion for boiler design
- 3-16. Why are single-furnace boilers often referred to as D-type boilers?
1. They are manufactured by the Delta Manufacturing Company
  2. The tubes form a shape that looks like the letter D
  3. The steam and water always flow down
  4. The D indicates a double boiler-wall thickness
- 3-17. In naval propulsion plants, where are the burners usually located?
1. At the front of the boiler
  2. At the back of the boiler
  3. On the right side of the boiler
  4. On the left side of the boiler
- 3-18. On almost all boilers used in the propulsion plants of naval ships, what protects the superheater tubes from radiant heat?
1. Water screen baffles
  2. Insulating block
  3. Air tubes
  4. Water screen tubes
- 3-1. What is the approximate operating pressure range for header-type boilers?
1. 300 to 425 psi
  2. 435 to 700 pal
  3. 700 to 825 pal
  4. 825 to 925 psi

- 3-20. What tubes lead from the water drum to the steam drum?
1. Generating tubes
  2. Sidewall tubes
  3. Superheater tubes
  4. Water wall tubes
- 3-21. Which of the following are used to reduce the swirling motion of the water as it enters the downcomers?
1. Scrubbers
  2. Screen plates
  3. Vortex eliminators
  4. Steam separators
- 3-22. Where does the steam go after it leaves the scrubbers?
1. To the cyclone steam separator
  2. To the front vortex eliminator
  3. To the surface blow pipe
  4. To the dry pipe
- 3-23. Which of the following devices break up the fuel into very fine particles?
1. Atomizers
  2. Diffuser plates
  3. Air foils
  4. Baffles
- 3-24. Hero designed and built which of the following types of engines?
1. Gas-powered
  2. Electric-powered
  3. Steam-powered
  4. Solar-powered
- 3-25. Hero's turbine (aeolipile) consists of a hollow sphere with a total of how many canted nozzles?
1. One
  2. Two
  3. Three
  4. Four
- 3-26. The water wheel that was used to operate the flour mills in colonial times and the common windmill used to pump water are examples of what principle?
1. The turbine principle
  2. The reciprocating engine principle
  3. The solar energy principle
  4. The gravity flow principle
- 3-27. What two methods are used in turbine design and construction to get the desired results from a turbine?
1. Steam and rotary principles
  2. Rotary and reciprocating
  3. Impulse and reaction principles
  4. Reaction and rotary principles
- 3-28. The energy to rotate an impulse turbine is derived from what source?
1. The potential energy of the heat flowing through the nozzles
  2. The kinetic energy of the steam flowing through the turbine shaft
  3. The mechanical energy of the turbine shaft derived from the atomizers
  4. The kinetic energy of the steam flowing through the nozzles
- 3-29. As the steam passes through a nozzle, potential energy is converted into what other type of energy?
1. Mechanical potential energy
  2. Kinetic energy
  3. Thermal energy
  4. Chemical energy
- 3-30. Impulse turbines may be used to drive which of the following equipment?
1. Forced draft blowers
  2. Pumps
  3. Main propulsion turbines
  4. All of the above

- 3-31. Hero's turbine was invented long before Newton's time, but it was a working model of Newton's
1. first law of motion
  2. second law of motion
  3. third law of motion
  4. fourth law of motion
- 3-32. What does a reaction turbine use to drive the rotor?
1. The reaction of a steam jet
  2. The reaction of a gas when converted to a solid
  3. The reaction of a water jet
  4. The reaction of a rapid change in steam temperature
- 3-33. What is generally stated in Newton's third law of motion?
1. For every action there must be an equal and opposite reaction
  2. Matter can be neither created nor destroyed
  3. The total quantity of energy in the universe is always the same
  4. At the molecular or submolecular level, heat transfer takes place through both the processes of conduction and radiation
- 3-34. In a reaction turbine, the stationary blades attached to the turbine casing act as nozzles and direct the steam to the
1. shaft
  2. bearings
  3. baffles
  4. moving blades
- 3-35. When you let the air escape through the small opening in a balloon, what energy transformation is taking place?
1. Kinetic energy to potential energy
  2. Potential energy to kinetic energy
  3. Thermal energy to chemical energy
  4. Mechanical energy to kinetic energy
- 3-36. A reaction turbine has all the advantages of an impulse-type turbine, plus which of the following features?
1. A slower operating speed
  2. Greater efficiency
  3. Both 1 and 2 above
  4. A faster operating speed
- 3-37. For nonsuperheated applications, turbine casings are made from which of the following materials?
1. Cast carbon steel
  2. Brass
  3. Tin
  4. Plastic
- 3-38. For superheated applications, turbine casings are made from which of the following materials?
1. Carbon molybdenum steel
  2. Cast carbon steel
  3. Brass
  4. Cast iron
- 3-39. What is the primary purpose of a turbine rotor?
1. To carry the moving blades that convert the steam's kinetic energy to rotating mechanical energy
  2. To convert mechanical energy to potential energy
  3. To carry the stationary blades that convert the steam's kinetic energy to chemical energy
  4. To convert kinetic energy to hydraulic energy
- 3-40. The rotor of every turbine must be positioned radially and axially by what means?
1. Brushes
  2. Wedges
  3. Spacers
  4. Bearings

- 3-41. Bearings are generally classified in which of the following ways?
1. Rotating or stationary
  2. Stationary surface or rotating
  3. Sliding surface or rolling contact
  4. Hard or soft
- 3-42. Which of the following devices are used to prevent the leaking of steam out of or air into the turbine casing where the turbine rotor shaft extends through the turbine casing?
1. Rubber gaskets
  2. Baffles
  3. Steam deflectors
  4. Shaft packing glands
- 3-43. Carbon packing rings mount around the turbine shaft and are held in place by which of the following devices?
1. Springs
  2. Spacers
  3. Washers
  4. Bolts
- 3-44. Normally, what does the term "superheat control boiler" identify?
1. A single-furnace boiler
  2. A double-furnace boiler
  3. An auxiliary boiler
  4. A natural-circulation boiler
- 3-45. The steam drum is a cylinder located at what boiler position?
1. At the top of the boiler
  2. At the bottom of the boiler
  3. On the left side of the boiler
  4. On the right side of the boiler
- 3-46. How are headers on a boiler identified?
1. By their shape
  2. By their size
  3. By their location
  4. By their color
- 3-47. The bottom blowdown valves should never be opened on a steaming boiler for which of the following reasons?
1. The circulation of the steam cycle will be interrupted
  2. The insulating firebrick will be damaged
  3. The baffle material will warp
  4. The air casing will crack
- 3-48. At each end of the steam drum are a number of large tubes that lead to the water drum and sidewall header. What are these tubes called?
1. Sidewall tubes
  2. Generating tubes
  3. Bottom blow tubes
  4. Downcomers
- 3-49. The sidewall (water wall) tubes in a boiler serve what function?
1. They heat the side wall of the furnace
  2. They cool and protect the side wall of the furnace
  3. They cool and protect the soot blower
  4. They heat the plastic chrome ore
- 3-50. The cyclone steam separators remove moisture from the steam, how is this accomplished?
1. By the steam flowing in a straight path
  2. By an internal fan or blower
  3. By the up and down movement of the separators
  4. By the steam spinning or changing direction
- 3-51. In some boilers, the superheater headers are installed parallel with the water drum and the tubes are installed vertically, What are these superheaters called?
1. Parallel superheaters
  2. Horizontal superheaters
  3. Vertical superheater
  4. Modified superheaters

- 3-52. As steam passes through the desuperheater, it is cooled for use in which of the following systems?
1. The economizer
  2. The auxiliary steam systems
  3. The main steam system
  4. The water wall tubes
- 3-53. The desuperheater may be located either in the steam drum or what other location?
1. The water drum
  2. The economizer
  3. The registers
  4. The ductwork
- 3-54. The furnace, or firebox, is the large space where air and fuel are mixed for the fire that heats the water in which of the following components?
1. Drums
  2. Tubes
  3. Headers
  4. All of the above
- 3-55. A forced draft blower is a large volume fan that can be powered by an electric motor or what other source?
1. A gas-driven engine
  2. A two-stage hydraulic motor
  3. A steam turbine
  4. An auxiliary
- 3-56. The return-flow atomizer provides a constant supply of fuel-oil pressure. Any fuel oil not needed to meet steam demand is returned to what location?
1. The whirling chamber
  2. The fuel-oil service tank
  3. The economizer
  4. The desuperheater
- 3-57. The vented-plunger atomizer is unique in that it is the only atomizer in use in the Navy that has which of the following features?
1. Moving parts
  2. Stationary parts
  3. A steam supply
  4. An oil supply
- 3-58. In most boilers, what is used to light fires?
1. A firing cap
  2. Flint
  3. A torch
  4. Friction igniters
- 3-59. For specific instructions on boiler light-off procedures, what should you refer to?
1. NSTM, Chap 555
  2. Your ship's EOSS
  3. NSTM, Chap 505
  4. NAVOSH Program Manual
- 3-60. For information on auxiliary boilers, you should refer to which of the following publications?
1. NSTM, Chap 555
  2. NSTM, Chap 505
  3. NSTM, Chap 254
  4. NSTM, Chap 221



## ASSIGNMENT

## 4

Textbook Assignment: "Gas Turbines," chapter 6, pages 6-1 through 6-20, and "Internal Combustion Engines," chapter 7, pages 7-1 through 7-14.

---

- 4-1. The patent application for the gas turbine, as we know it today, was submitted in 1930 by what person?
1. Sir Frank Whittle
  2. Christian Huygens
  3. Thomas Young
  4. Augustin Fresnel
- 4-2. The United States entered the gas turbine field in what year?
1. 1910
  2. 1941
  3. 1953
  4. 1961
- 4-3. The first jet aircraft was flown in the United States in what year?
1. 1910
  2. 1920
  3. 1931
  4. 1942
- 4-4. The U.S. Navy entered the marine gas turbine field with which of the following types of ships?
1. Aircraft carriers
  2. Battleships
  3. Patrol gunboats
  4. Destroyers
- 4-5. What is basically stated in Newton's third law of motion?
1. For every reaction there is an equal and opposite action
  2. For every action there is an unequal and opposite reaction
  3. For every unequal action there is an unequal reaction
  4. For every action there is an equal and opposite reaction
- 4-6. The Otto cycle consists of how many basic events?
1. One
  2. Two
  3. Three
  4. Four
- 4-7. What are the two primary means of classifying gas turbine engines?
1. By the type of compressor used and how the power is used
  2. By the type of pistons used and how the power is used
  3. By the type of fuel used and the weight
  4. By the length of the engines and their rated horsepower
- 4-8. Most gas turbines of modern design use what type of compressor?
1. Single-entry
  2. Dual-entry
  3. Triple-entry
  4. Single-stage
- 4-9. In the axial-flow engine, where is the compressor located?
1. On the side of the engine
  2. At the rear of the engine
  3. At the front of the engine
  4. On top of the engine
- 4-10. What are the three basic types of gas turbines in use?
1. Dual shaft, twin spool, and split end
  2. Single spool, common shaft, and split shaft
  3. Single shaft, split end, and twin spool
  4. Single shaft, split shaft, and twin spool

- 4-11. In current U.S. Navy service, the single-shaft turbine engine is used primarily for what purpose?
1. Driving ship's service generator
  2. Propelling aircraft carrier
  3. Driving auxiliary steam compressors
  4. Propelling small boats
- 4-12. What are the four major sections of a gas turbine engine?
1. Compressor, igniter, turbine, and hydraulic
  2. Compressor, auxiliary, combustor, and turbine
  3. Compressor, combustor, turbine, and accessory
  4. Turbine, auxiliary, hydraulic, and compressor
- 4-13. What are the three types of combustion chambers?
1. Hot air, forced draft, and stationary
  2. Can, annular, and can-annular
  3. Closed, open, and stationary
  4. Dual shaft, twin spool, and annular
- 4-14. The annular combustion liner is usually found on what type of engines?
1. Dual-compressor
  2. Axial-flow
  3. Single-stage
  4. Dual-stage
- 4-15. In theory, design, and operating characteristics, the turbines used in gas turbine engines are quite similar to the turbines used in
1. an electrical power generating system
  2. a reciprocating power plant
  3. an emergency generator
  4. a steam plant
- 4-16. The ship's propulsion plant can be operated from which of the following stations?
1. The local control console
  2. The central control console
  3. The ship control console
  4. All of the above
- 4-17. When compared to other engines, what is the gas turbine's greatest asset?
1. Its low fuel consumption
  2. Its high power-to-weight ratios
  3. Its low maintenance cost
  4. Its ability to resist corrosion
- 4-18. Internal combustion engines convert heat energy into what other type of energy?
1. Mechanical energy
  2. Hydraulic energy
  3. Electrical energy
  4. Potential energy
- 4-19. The back-and-forth motion of the pistons in an engine is known as
1. combustion motion
  2. mechanical motion
  3. reciprocating motion
  4. rotary motion
- 4-20. In the internal combustion engine, what changes reciprocating motion to rotary motion?
1. A crankshaft
  2. A connecting rod
  3. Both 1 and 2 above
  4. A piston
- 4-21. Which of the following parts will NOT be found on a diesel engine?
1. Pistons
  2. Valves
  3. Spark plugs
  4. Connecting rods
- 4-22. In the internal combustion engine, what are the four basic strokes?
1. Intake, extension, power, and exhaust
  2. Intake, compression, power, and exhaust
  3. Intake, reduction, expansion, and exhaust
  4. Compression, expansion, extension, and power

- 4-23. On a four-stroke engine, the camshaft turns at one-half
1. piston speed
  2. push rod speed
  3. timing gear speed
  4. crankshaft speed
- 4-24. In a four-stroke engine, how many crankshaft revolutions are required to complete one cycle?
1. One
  2. Two
  3. Three
  4. Four
- 4-25. In a four-stroke engine, how many piston strokes are required to complete one cycle?
1. One
  2. Two
  3. Three
  4. Four
- 4-26. In a four-stroke engine, each piston makes one power stroke for each
1. revolution of the crankshaft
  2. two revolutions of the crankshaft
  3. three revolutions of the crankshaft
  4. four revolutions of the crankshaft
- 4-27. In a four-stroke engine, the intake valve is open and the exhaust valve is closed during what piston stroke?
1. Intake
  2. Compression
  3. Power
  4. Exhaust
- 4-28. In a diesel engine, a charge of fuel is forced into the cylinder when the piston nears the top of what stroke?
1. Intake
  2. Compression
  3. Power
  4. Exhaust
- 4-29. In a gasoline engine, the fuel air mixture is ignited by a spark plug near the top of what piston stroke?
1. Intake
  2. Compression
  3. Power
  4. Exhaust
- 4-30. In a two-stroke diesel engine, how often in the cycle does the power stroke occur?
1. Every stroke
  2. Every second stroke
  3. Every third stroke
  4. Every fourth stroke
- 4-31. Which of the following parts will NOT be found in a two-stroke engine?
1. Pistons
  2. Exhaust valves
  3. Intake valves
  4. Cylinders
- 4-32. In a four-stroke engine, how fast does the camshaft turn in relation to the crankshaft?
1. 1/2 as fast as the crankshaft
  2. 1/3 as fast as the crankshaft
  3. 1/4 as fast as the crankshaft
  4. 1/8 as fast as the crankshaft
- 4-33. The relation between the volume of the cylinder with the piston at the bottom of its stroke and the cylinder volume with the piston at the top of its stroke is called the
1. displacement ratio
  2. travel ratio
  3. stroke length
  4. compression ratio
- 4-34. As the compression ratio is increased, what, if anything, happens to the temperature of the air in the cylinder?
1. It decreases
  2. It increases
  3. It decreases rapidly, then increases
  4. Nothing

- 4-35. Current gasoline engines operate at which of the following compression ratios?
1. Between 6:1 and 11:1
  2. Between 11:1 and 12:5
  3. Between 12:5 and 13:1
  4. Between 13:1 and 14:5
- 4-36. Current diesel engines operate at which of the following compression ratios?
1. Between 10:1 and 11:1
  2. Between 11:1 and 12:1
  3. Between 12:1 and 19:1
  4. Between 19:1 and 20:5
- 4-37. The lubricating system of an engine delivers oil to the moving parts for which of the following purposes?
1. To reduce friction
  2. To assist in keeping the parts cool
  3. To prevent serious damage to engine parts
  4. All of the above
- 4-38. Most diesel and gasoline engines are equipped with what type of lubricating system?
1. Splash
  2. Pressure
  3. Gravity feed
  4. Immersion
- 4-39. To carry away the excess heat produced in the engine cylinders, marine engines are equipped with what type of cooling system?
1. Oil
  2. Water
  3. Alcohol
  4. Air
- 4-40. Which of the following types of starting systems are used in internal combustion engines?
1. Electric
  2. Hydraulic
  3. Compressed air
  4. All of the above
- 4-41. Electric starting systems in internal combustion engines use which of the following types of current?
1. Direct current
  2. Alternating current
  3. Magnetic current
  4. All of the above
- 4-42. What are the two distinct circuits in the ignition system of a gasoline engine?
1. Alternating and direct
  2. Mechanical and electric
  3. Primary and secondary
  4. Hot and cold
- 4-43. Which of the following events happens at the exact instant that a cylinder is due to fire in a gasoline engine?
1. The ignition breaker points open
  2. The ignition breaker points close
  3. Fuel is injected directly into the cylinder
  4. The intake valve closes
- 4-44. On a gasoline engine, the distributor is connected to what circuit?
1. Primary
  2. Secondary
  3. Low-voltage
  4. Mechanical
- 4-45. In a gasoline engine, the high voltage that jumps the gap in the spark plugs comes from what source?
1. The battery
  2. The generator
  3. The starter
  4. The ignition coil
- 4-46. In an operating gasoline engine system, which of the following happens when the breaker points open?
1. High voltage is produced in the primary circuit
  2. Low voltage is produced in the secondary circuit
  3. High voltage is produced in the secondary circuit
  4. Low voltage is produced in the generator circuit

- 4-47. In a gasoline engine ignition circuit, what is the primary purpose of the condenser?
1. To protect the breaker points from being burned
  2. To produce high-voltage current
  3. To reduce the moisture content in the distributor
  4. To aid in producing a colder spark
- 4-48. In electronic ignition systems, what opens and closes the primary circuit?
1. Breaker points
  2. A can
  3. A mechanical switch
  4. An electronic control unit
- 4-49. What type of energy is contained in fuel for operating engines?
1. Kinetic
  2. Potential
  3. Pneumatic
  4. Hydraulic
- 4-50. In a diesel engine, which of the following is drawn into the cylinders on the intake stroke?
1. Fresh air
  2. Fuel
  3. Both 2 and 3 above
  4. Oil
- 4-51. Which of the following controls the speed of a diesel or gasoline engine?
1. The ignition timing
  2. The carburetor discharge pressure
  3. The valve overlap setting
  4. The amount of fuel and air mixture burned in the cylinders
- 4-52. The push or pressure created in an engine cylinder to move the piston is a result of what action?
1. The reciprocating motion of the connecting rod
  2. The rotary motion of the camshaft
  3. Burning of a mixture of fuel and air
  4. The governor drive assembly
- 4-53. As the piston nears the bottom of the power stroke in a two-stroke diesel engine, the exhaust valves open and the piston continues downward to
1. uncover the intake ports
  2. cover the intake ports
  3. uncover the fuel regulator valve
  4. cover the exhaust ports
- 4-54. In many respects, an ignition coil on a gasoline engine ignition system is similar to
1. a battery
  2. a condenser
  3. an electromagnet
  4. a spark plug
- 4-55. In a gasoline engine ignition system, what prevents arcing across the breaker points?
1. A high tension coil
  2. A low tension coil
  3. An insulated distributor cap
  4. A condenser
- 4-56. On the compression stroke in a diesel engine, the air is compressed and the temperature in the cylinder will rise to what maximum temperature?
1. 1,200°F
  2. 1,100°F
  3. 1,000°F
  4. 700°F
- 4-57. Each movement of the piston in an engine from top to bottom or from bottom to top is known by what term?
1. Event
  2. Stroke
  3. Cycle
  4. Transaction

4-58. On some types of engines, the camshaft is located near the crankshaft. In these designs, the action of the cam roller is transmitted to the rocker arm by what means?

1. A spring
2. A lever
3. A push rod
4. A crankshaft

4-59. In the two-stroke engine, the camshaft rotates at what speed in relation to the crankshaft?

1. The camshaft rotates at one-half the speed of the crankshaft
2. The camshaft rotates at twice the speed of the crankshaft
3. The camshaft rotates at four times the speed of the crankshaft
4. The camshaft rotates at the same speed as the crankshaft

4-60. You can find detailed information on compression ignition systems in which of the following publications?

1. NSTM, chap 422
2. NAVEDTRA 10539
3. OPNAVINST 4790.4
4. OPNAVINST 1500.22

## ASSIGNMENT 5

Textbook Assignment: "Ship Propulsion," chapter 8, pages 8-1 through 8-8, "Pump, Valves, and Piping," chapter 9, pages 9-1 through 9-49, and "Auxiliary Machinery and Equipment," chapter 10, pages 10-1 through 10-54.

---

- 5-1. The primary function of any marine engineering plant is to convert the chemical energy of a fuel into useful work and use that work for what purpose?
1. Propulsion of the ship
  2. Decontamination of the ship
  3. Operation of hydraulic clutches
  4. Production of steam
- 5-2. What type of propeller is used in most naval ships?
1. Gear
  2. Paddle
  3. Thrust
  4. Screw
- 5-3. Steam propulsion-type ships built since 1935 have what type of propulsion gears?
1. Single reduction
  2. Double reaction
  3. Double reduction
  4. High-speed reaction
- 5-4. Pneumatic clutches with a cylindrical friction surface are used with engines up to what maximum horsepower?
1. 1,000 hp
  2. 2,000 hp
  3. 3,000 hp
  4. 4,000 hp
- 5-5. What are the two general styles of friction clutches?
1. hydraulic and mechanical
  2. Disk and band
  3. Hard and soft
  4. Gear and rod
- 5-6. What are the two general types of friction clutches?
1. Dry and wet
  2. Hard and soft
  3. Disk and band
  4. Air and hydraulic
- 5-7. A screw propeller may be broadly classified by which of the following terms?
1. Single pitch or double pitch
  2. Stationary angle or variable angle
  3. Fixed pitch or controllable pitch
  4. Stationary pitch or variable rotation
- 5-8. Classification of centrifugal pumps is based on which of the following factors?
1. Self-priming ability
  2. Positive displacement
  3. Number of impellers
  4. Position of moving vanes
- 5-9. The sidewalls of a closed impeller extend from what point to what other point?
1. (a) The eye  
(b) outer edge of vane tips
  2. (a) Suction line  
(b) wearing rings
  3. (a) Stuffing box  
(b) the eye
  4. (a) The water seal  
(b) discharge line

- 5-10. High-speed impellers must be balanced to avoid vibration. What is the purpose of a close radial clearance between the outer hub and the pump casing?
1. To decrease friction
  2. To decrease axial thrust
  3. To minimize leakage from the suction side
  4. To minimize leakage from the discharge side
- 5-11. What is the function of mechanical seals and stuffing boxes?
1. To improve pump operation
  2. To seal between the shaft and the casing
  3. To clean bilges
  4. To prevent liquid from being pumped
- 5-12. What type of pump is considered to be nonpositive displacement?
1. Sliding vane
  2. Rotary
  3. Centrifugal
  4. Jet
- 5-13. A pump that does not develop enough discharge pressure could have which of the following problems?
1. Clogged impeller passages
  2. A bent shaft
  3. Excessive suction lift
  4. Insufficient pump speed
- 5-14. Which of the following statements about a centrifugal pump is true?
1. It is essentially self-priming
  2. It loses no energy
  3. It is a positive-displacement pump
  4. It requires a relief valve
- 5-15. What type of pump has no moving parts?
1. Screw
  2. Jet
  3. Gear
  4. Sliding vane
- 5-16. What device uses feedback to provide automatic control of speed, pressure, or temperature?
1. Regulating valve
  2. Flange coupling
  3. Proportional-flow filter
  4. Governor
- 5-17. What is the purpose of a valve in a closed system?
1. To sample fluids
  2. To control fluids
  3. To increase fluid pressure
  4. To decrease fluid pressure
- 5-18. Brass and bronze valves are never used in systems that exceed what maximum temperature?
1. 450°F
  2. 550°F
  3. 650°F
  4. 750°F
- 5-19. There are many different types of valves that can be used to control fluid flow. What are the two basic groups of valves?
1. Globe and check
  2. Check and gate
  3. Stop and check
  4. Gate and globe
- 5-20. Due to valve design, gate valves are not used for throttling purposes for which of the following reasons?
1. They make it difficult to control fluid flow and can damage valves
  2. They make it difficult to control fluid flow and are too lightweight
  3. They can damage valves and are too lightweight
  4. They make it difficult to control fluid flow and are excessively expensive



5-21. In how many directions will a check valve allow fluid to flow?

1. One
2. Two
3. Three
4. Four

5-22. What type of valve requires a 90-degree turn to operate the valve in either the completely open or closed position?

1. Check valve
2. Gate valve
3. Ball valve
4. Butterfly valve

5-23. If a constant-pressure pump governor is attached to a gear pump, to which of the following parts is the governor connected?

1. The driving gear
2. The driven gear
3. The suction line
4. The discharge line

5-24. You can close a butterfly valve by using which of the following procedures?

1. Depress a push button
2. Lift up on a handle
3. Turn the handle one-fourth turn
4. Turn the handle one-half turn

5-25. Whether a stop-check valve acts as a stop valve or as a check valve is determined by which of the following factors?

1. The position of the control lever
2. The direction of the flow
3. The type of disk installed
4. The position of the valve stem

5-26. In a piping system, relief valves automatically open when what factor has been exceeded?

1. The temperature
2. The pressure
3. The flow
4. The circulation

5-27. Reducing valves in reduced pressure systems are designed to be used for which of the following purposes?

1. To prevent damage to the lines due to excessive pressure
2. To provide a steady pressure lower than the supply pressure
3. To vary the operating pressure and the supply pressure
4. Each of the above

5-28. Fuel oil suction may be taken from one of many sources and discharged to another unit or units of the same group by what device?

1. Priority valve
2. Globe valve
3. Valve manifold
4. Operating lever

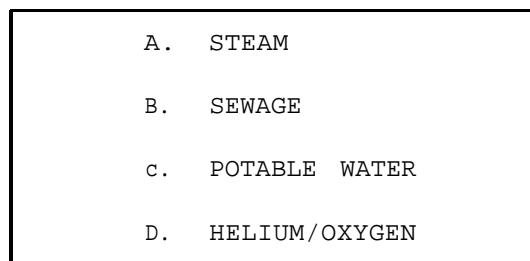

**Figure 5A**

IN ANSWERING QUESTIONS 5-29 THROUGH 5-31, REFER TO FIGURE 51 AND SELECT THE FLUID THAT CORRESPONDS TO THE COLOR CODE FOR VALVE HANDWHEELS AND OPERATING LEVERS .

5-29. Gold.

1. A
2. B
3. C
4. D

5-30. Striped buff/green.

1. A
2. B
3. C
4. D

- 5-31. Dark blue.
1. A
  2. B
  3. C
  4. D
- 5-32. What method is used to visually determine whether the seat and the disk of a valve make good contact?
1. Seating-in
  2. Spotting-in
  3. Grinding-in
  4. Lapping
- 5-33. What manual process should you use to remove small valve seat and disk irregularities?
1. Seating-in
  2. Spotting-in
  3. Grinding-in
  4. Lapping
- 5-34. Which of the following devices are designed to drain condensate from steam lines without allowing steam to escape?
1. Steam stops
  2. Condensate drain valves
  3. Filters and strainers
  4. Steam traps
- 5-35. What device has the function of retaining insoluble contaminants by use of some porous medium?
1. A strainer
  2. A filter
  3. A trap
  4. An element
- 5-36. To determine the size of tubing, which of the following measurements is used?
1. The actual inside diameter
  2. The nominal outside diameter
  3. The nominal outside circumference
  4. The nominal inside circumference
- 5-37. Resistance to corrosion and the ability to withstand high pressure and temperature are important factors in choosing a material for a piping system. Which of the following types of tubing should be used?
1. Steel alloy
  2. Copper alloy
  3. Aluminum alloy
  4. Brass alloy
- 5-38. Flexible hose is identified by the manufacturer's part number and the size or dash number. Which of the following is the best description of the dash number?
1. The outside diameter in eighth-inch increments
  2. The inside diameter in sixteenth-inch increments
  3. The outside circumference in eighth-inch increments
  4. The inside circumference in sixteenth-inch increments
- 5-39. Gaskets in flange joints of a pipe are used for what purpose?
1. To allow for misalignment
  2. To allow for expansion
  3. To serve as a spacer
  4. To prevent leakage
- 5-40. Packing material used for sealing is placed in or on which of the following areas?
1. In the stuffing box
  2. On the outside of the stuffing box
  3. In the revolving shaft
  4. On top of the valve stem

- 5-41. Upon completion of visual inspection of a flexible hose assembly, a hydrostatic test is done to ensure what allowable maximum pressure?
1. Rated pressure for 1 hour
  2. Twice the rated pressure for 1 hour
  3. Rated pressure for not less than 1 minute
  4. Twice the rated pressure for not less than 1 minute
- 5-42. Hose assemblies intended for gas or air service must be tested with
1. compressed air at 1 psi
  2. hydrogen at 10 psi
  3. nitrogen at 100 psi
  4. oxygen at 1,000 psi
- 5-43. Fittings are used to connect pipe, tube, or hose to system components. One type of fitting is the bolted flange joint, which is used in systems operating at which of the following pressures?
1. 100 psi
  2. 1,000 psi
  3. 10,000 psi
  4. All pressures now in use
- 5-44. The use of flange safety shields reduces the possibility of which of the following problems?
1. Fuel oil leaks
  2. MER flooding
  3. AMR fuel fires
  4. Lube oil pooling
- 5-45. Many shipboard machinery casualties have resulted from fasteners that were not properly installed. Which of the following reasons can cause fasteners to loosen?
1. Machinery vibration
  2. Thermal expansion
  3. Thermal contraction
  4. Each of the above
- 5-46. When installed and tightened, male threaded fasteners protrude at least one thread length beyond the top of the nut or plastic locking ring. The number of threads should not exceed five and in no case should thread protrusion exceed ten threads. This is the 1 to 10 rule.
1. True
  2. False
- 5-47. Which of the following phrases best describe the refrigeration effect?
- A. Heat will flow from a colder to a warmer object or environment
  - B. Heat will flow from a warmer to a colder object or environment
  - C. An artificial way of lowering the temperature
  - D. A mechanical transformation of the surrounding atmosphere
1. A and D
  2. B and C
  3. A and D
  4. C and D
- 5-48. What is the unit of measurement for the amount of heat removed in a refrigeration system?
1. Btu
  2. SAE
  3. Latent heat
  4. Refrigeration ton
- 5-49. Which of the following is/are the main part(s) of the R-12 system?
1. TXV
  2. Capacity control system
  3. Receiver
  4. All of the above
- 5-50. What device maintains a constant refrigerant condensing pressure?
1. Evaporator
  2. Capacity control system
  3. Water regulating valve
  4. Compressor

- 5-51. At what temperature will R-12 boil at atmospheric pressure?
1. 12°F
  2. 0°F
  3. -12°F
  4. -21°F
- 5-52. Which of the following fans is generally preferred for exhaust systems that handle explosive or hot gases?
1. Centrifugal
  2. Vane-axial
  3. Tube axial
- 5-53. The vapor compression chilled water circulating system differs from a refrigerant circulating air-conditioning system in what way?
1. Method of evaporation
  2. Method of compression
  3. Method of condensing
- 5-54. Air compressors may be classified according to
1. make, model, and oil-free discharge
  2. pressure, oil-free discharge, and type of compressing element
  3. pressure, model, and oil-free discharge
  4. type of compressing element, make, and model
- 5-55. Which of the following prime movers is directly connected to the vertical, five-stage, reciprocating high-pressure air compressor?
1. Steam turbine
  2. Diesel engine
  3. Electric motor
  4. Pneumatic turbine
- 5-56. Medium-pressure air compressors have a discharge pressure range between
1. 51 and 100 psi
  2. 101 and 150 psi
  3. 151 and 1000 psi
  4. 1001 and 1200 psi
- 5-57. Dehydrators are used for which of the following purposes?
1. To compress air
  2. To cool compressed air
  3. To add moisture to compressed air
  4. To remove moisture from compressed air
- 5-58. Condensed vapor that is produced by a distilling plant is pumped to which of the following locations?
1. The firemain system
  2. The condensate system
  3. The ship's freshwater tank
  4. The overboard discharge tank
- 5-59. What is the purpose of the three wings on the tubular-type oil purifier?
1. They keep the oil rotating at the speed of the bowl
  2. They collect the sediment or other impurities
  3. They separate the oil into three layers
  4. They help accelerate the rotation of the bowl
- 5-60. The direction of fluid flow in the electrohydraulic steering gears depends on which of the following factors?
1. Hydraulic ram
  2. Tilt box angle
  3. Power unit
  4. Axial piston
- 5-61. What component is used for heaving in heavy mooring lines?
1. Winches
  2. Windlasses
  3. Wild cats
  4. Whelps

- 5-62. The gypsy head on an electro-hydraulic winch is connected to the shaft by what means?
1. By adjusting the stroke of its hydraulic pump
  2. By using a clutch
  3. By adjusting the clearance between the friction surfaces of its brake
  4. By regulating the operating voltage of its ac motor
- 5-63. If the hoisting cables should break on one side of an electro-hydraulic elevator, which of the following devices will prevent the elevator from falling?
1. The guide rails
  2. The special control valves
  3. The mechanical locks
  4. The serrated safety shoes
- 5-64. To prevent excessive pressure in the oil feed lines of a lube oil pump system, which of the following types of valves should be used?
1. Governor
  2. Relief
  3. Throttle
  4. Reducing
- 5-65. To get the desired temperature of oil leaving a tube-in-shell type of oil cooler, which of the following cooling actions is regulated?
1. The oil flow
  2. The airflow
  3. The seawater flow
  4. The freshwater flow
- 5-66. Under ideal conditions, what kind of friction, if any, occurs when a main shaft rotates in a properly lubricated main journal bearing?
1. Fluid
  2. Sliding
  3. Rolling
  4. None
- 5-67. Mineral lubricating oils can withstand the effects of high temperature and high speeds better than either animal or vegetable oils.
1. True
  2. False
- 5-68. Main propulsion turbines and reduction gears use which of the following types of oil lubrication?
1. 9110
  2. 3290
  3. 3190 TEP
  4. 2190 TEP

## ASSIGNMENT 6

Textbook Assignment: "Instruments," Shipboard Electrical Equipment," and "Environmental Controls," chapters 11, 12, and 13, pages 11-1 through 13-7.

---

- 6-1. In a shipboard engineering plant, the instruments let operating personnel perform which of the following tasks?
1. Determine if machinery is operating within a prescribed range
  2. Determine the operating efficiency of the plant
  3. Provide data for reports and records
  4. Each of the above
- 6-2. On a pressure gauge, the red hand (if installed) should be set at what point?
1. Zero
  2. Slightly above the maximum normal operating pressure only
  3. Slightly below the minimum normal operating pressure only
  4. Slightly above or slightly below the maximum or minimum normal operating pressure
- 6-3. A Bourdon-tube gauge operates on what principal?
1. Volume changes in a straight tube tend to expand the tube
  2. Volume changes in a coiled tube tend to collapse the tube
  3. Pressure in a straight tube tends to bend the tube
  4. Pressure in a curved tube tends to straighten the tube
- 6-4. If a curved Bourdon tube is used to measure pressure that exceeds 200 psi, it is made from what metal?
1. Copper
  2. Bronze
  3. Steel
  4. Lead
- 6-5. In a simplex gauge, the free end of the Bourdon tube is attached to the indicating mechanism by a
1. linkage assembly
  2. wire
  3. cam
  4. bellows assembly
- 6-6. You would use a simplex Bourdon-tube gauge if you were taking which of the following measurements?
1. The water depth in a freshwater tank
  2. The amount of fuel oil flowing through a valve
  3. The pressure in a compressed air system
  4. The pressure drop between the inlet and the outlet side of a lube oil strainer
- 6-7. Vacuum gauges, which are used to indicate pressures below atmospheric pressure, have which of the following units of measurement?
1. Inches of water
  2. Inches of mercury
  3. Pressure per inch
  4. Pressure per square inch
- 6-8. What Bourdon-tube gauge should you use to take pressure and vacuum measurements?
1. Duplex
  2. Simplex
  3. Compound
  4. Differential
- 6-9. What type of gauge should be installed to check the pressure between the inlet and outlet sides of lube oil strainers?
1. Duplex
  2. Simplex
  3. Compound
  4. Diaphragm

- 6-10. A bellows gauge can be used to take which of the following measurements?
1. Pressure up to 800 psig
  2. Low pressures
  3. Small pressure differentials
  4. Each of the above
- 6-11. To measure pressure in the space between the inner and outer boiler casings, which of the following types of gauges is generally used?
1. A compound Bourdon-tube gauge
  2. A duplex Bourdon-type gauge
  3. A diaphragm gauge
  4. A bellows gauge
- 6-12. A U-tube that is open to the atmosphere at one end and connected to a pressure source at the other end is known as a
1. bellows
  2. manometer
  3. diaphragm
  4. Bourdon tube
- 6-13. The liquid in the capillary bore of a liquid-in-glass thermometer responds to a change in temperature by expanding or contracting, which causes what type of change, if any, in the thermometer graduations?
1. Relatively large
  2. Relatively small
  3. Inversely proportional
  4. None
- 6-14. The element of a bimetallic expansion thermometer responds to a rise in temperature in what way?
1. By rising
  2. By contracting
  3. By changing colors
  4. By changing the curvature
- 6-15. Which of the following is NOT a component of a distant-reading thermometer?
1. Bulb
  2. Capillary tube
  3. Thermocouple
  4. Bourdon tube
- 6-16. Aboard ship, the exhaust temperature of diesel engines and heat-treatment furnaces is measured using what instrument?
1. A distant-reading thermometer
  2. A bimetallic thermometer
  3. A resistance thermometer
  4. A pyrometer
- 6-17. The metals that make up the actuating element of a pyrometer respond to a rise in temperature by producing a/an
1. chemical reaction
  2. electrical current
  3. mechanical change
- 6-18. In the newer propulsion plants, temperatures are remotely monitored. Thermocouple temperature detectors are used with what other components to provide indications and alarms to the various engineering consoles?
1. Signal conditioners
  2. Signal multipliers
  3. Signal processors
  4. Signal reversers
- 6-19. A resistive temperature detector (RTD) with a nickel element is used to measure temperatures in which of the following ranges?
1. 400° to 600°F
  2. 600° to 800 °F
  3. 800° to 1,000°F
  4. 1,000° to 1,200°F

- 6-20. The RTD elements designed for 600°F or greater service are made of what metal?
1. Copper
  2. Nickel
  3. Platinum
  4. Silver
- 6-21. As temperature increases around an RTD, what will happen to the corresponding resistance of the RTD?
1. It remains the same
  2. It increases by a proportional value
  3. It decreases by a proportional value
  4. It fluctuates erratically
- 6-22. You are troubleshooting an RTD circuit. What is indicated by a very low or zero meter reading?
1. A short circuit
  2. An open circuit
  3. An abnormal reading; but not an immediate problem condition
  4. A normal reading; circuit malfunction is not indicated
- 6-23. If the RTD of a 0° to 300°F meter were to open, you would expect to receive which of the following indications?
1. 100°F
  2. 200°F
  3. 300 °F
  4. 0°F
- 6-24. At the shipboard level, what corrective maintenance should you perform on a defective RTD?
1. Remove the RTD and repair it in the shop
  2. Remove the RTD and replace it with a new one
  3. Repair the RTD in place
- 6-25. Meters on control consoles display units of pressure or temperature; but, they are actually what type of meter?
1. Ohmmeter
  2. Ammeter
  3. Dc voltmeter
  4. Wattmeter
- 6-26. Voltmeters installed in switchboards (SWBD) and control consoles all have what type of resistive value?
1. Adjustable
  2. Variable
  3. Fixed
  4. Indefinite
- 6-27. To allow an ammeter to handle high SWBD current, what component is installed with it?
1. A current transformer
  2. A potential transformer
  3. A step-down transformer
  4. A step-up transformer
- 6-28. A failing generator is being operated in parallel with a good generator. Normally, the loss of which of the following outputs indicates this condition?
1. Voltage
  2. Amperage
  3. Frequency
  4. Kilowatt load
- 6-29. You are observing a synchroscope, and the output frequency of the oncoming generator and the on-line generator is the same. What indication will you receive from the moving element (pointer)?
1. It holds a fixed position
  2. It rotates slow in the fast direction
  3. It rotates fast in the slow direction
  4. It oscillates erratically between the fast and slow directions



- 6-30. What condition is indicated when the three neon lamps located on the face of the phase-sequence indicators are lit?
1. Three cables are connected to the bus
  2. The phase-sequence is correct
  3. All three phases are energized
  4. One of the three fuses has blown
- 6-31. Which of the following sensors is used to determine the specific level in a fuel tank at any given time ?
1. Tank level indicator (TLI)
  2. Liquid level indicator (LLI)
  3. Float level
  4. Contact level
- 6-32. A typical TLI transmitter section contains what type of voltage network?
1. Multiplier resistor
  2. Multiplier inductor
  3. Divider resistor
  4. Divider inductor
- 6-33. In a seawater-compensated fuel tank, the float of the TLI is designed to stay at what location?
1. At the top of the fuel
  2. At the seawater/fuel interface
  3. At the bottom of the seawater
  4. Between the seawater/full interface and the top of the tank
- 6-34. To measure the rotational speed of a shaft, what instrument is commonly used?
1. A hydrometer
  2. A tachometer
  3. A manometer
  4. A barometer
- 6-35. The propeller indicator mounted on the propulsion shaft can give which of the following information about the shaft rotation?
1. The direction of rotation
  2. The number of revolutions
  3. The speed of rotation
  4. All of the above
- 6-36. What tachometer has a flashing light that determines the speed of a rotating shaft?
1. Hand-held mechanical
  2. Resonant reed
  3. Stroboscope
  4. Chronometric
- 6-37. What instrument is used to indicate the salt content of the ship's distilled water?
1. A liquid level indicator
  2. A salinity indicator
  3. A pressure indicator
  4. A chemical indicator
- 6-38. To apply a specific, predetermined amount of torsion to a bolt on the main engine, you should use what type of wrench?
1. Torque
  2. Ratchet
  3. Crescent
  4. Combustion
- 6-39. While using a micrometer-setting torque wrench, the user knows the desired torque has been reached when
1. a predetermined setting initiates an audible click
  2. the needle reaches the desired torque on the dial indicator
  3. the deflecting beam reaches the desired torque
  4. the pointer reaches the torque indicator

- 6-40. Before using a torque wrench, you should check which of the following labels?
1. Safety
  2. Adjustment
  3. Collimation
  4. Calibration
- 6-41. Which of the following substances offers resistance to electric current?
1. Iron
  2. Copper
  3. Aluminum
  4. Mica
- 6-42. What term defines the rate at which current passes through a circuit?
1. Ampere
  2. volt
  3. ohm
  4. Watt
- 6-43. A unit of electrical resistance is known as a/an
1. watt
  2. ampere
  3. ohm
  4. volt
- 6-44. A soldering iron is rated at 100 watts. This statement provides which of the following information about the soldering iron?
1. The power consumed by the soldering iron
  2. The emf of the iron
  3. The resistance of the iron
  4. The rate at which current flows through the soldering iron
- 6-45. A shipboard generator operates at maximum efficiency under which of the following conditions?
1. At full-rated load
  2. With all batteries fully charged
  3. At periods of minimum power demand
  4. When in series with other generators of the same rated output
- 6-46. The rotating member of a dc generator is known as the
1. field winding
  2. armature
  3. rotor
  4. yoke
- 6-47. Most emergency generators installed on ships operate at what voltage and frequency, respectively?
1. 450 volts, 60 hertz
  2. 220 volts, 50 hertz
  3. 450 volts, 50 hertz
  4. 110 volts, 60 hertz
- 6-48. Revolving-field generators are superior to revolving-armature generators for which of the following reasons?
1. The load current from the stator is connected to the external circuit without the use of a commutator
  2. Only two slip rings are required to supply excitation
  3. The stator windings are not subjected to mechanical stresses
  4. All of the above

- 6-49. A high-speed, turbine-driven alternator is prevented from overheating by which of the following safety provisions?
1. An alternator used with other alternators that automatically goes off when it becomes warm
  2. A forced air ventilation system that circulates air through the stator and rotor
  3. A heat-limiting governor that controls the temperature
  4. A metal structure surrounded by cold water that encases the alternator parts
- 6-50. Turbines that drive the ships service generators receive their energy from what source?
1. Batteries
  2. Diesel engines
  3. Saturated steam
  4. Superheated steam
- 6-51. Ships generators supply electricity at a constant voltage and frequency. For this to happen, what condition must be met?
1. A high-frequency output
  2. A low-frequency output
  3. The turbines must operate at a variable speed to meet demands of variable loads
  4. The turbines must operate at a constant speed under variable loads
- 6-52. Emergency generators are driven by diesel power rather than steam turbine power because diesel engines have what advantage?
1. They generate more power than turbines
  2. They start faster than turbines
  3. They are easier to operate than turbines
  4. They are less of a fire hazard than turbines
- 6-53. Special, closely regulated electrical power used for specific loads is furnished by which of the following power suppliers?
1. Turbine generator
  2. Diesel generator
  3. Motor generator
  4. Ship's service switchboard
- 6-54. Ship's service-generating units and their associated distribution switchboards are interconnected to other distribution switchboards by what circuit?
1. Short
  2. Bypass
  3. Bus tie
  4. Alternator
- 6-55. During load changes, the automatic voltage regulator maintains a constant voltage by varying the
1. armature resistance
  2. field excitation
  3. generator speed
  4. governor speed
- 6-56. What device is used to isolate a faulty circuit?
1. A resistor
  2. A rectifier
  3. A circuit breaker
  4. A voltage regulator
- 6-57. What device maintains the generator voltage to within specified limits?
1. A voltmeter
  2. A voltage regulator
  3. A circuit generator
  4. A resistor regulator
- 6-58. An ac motor has which of the following advantages over a dc motor?
1. It is larger
  2. It is smaller
  3. It requires less power
  4. It rotates at a faster speed

- 6-59. Shipboard motor controllers are used for which of the following purposes?
1. To start and to stop motors
  2. To increase or decrease motor speed
  3. To reverse the direction of a rotating shaft
  4. Each of the above
- 6-60. Which of the following pieces of equipment may be equipped with electric brakes?
1. Anchor windlasses
  2. Auxiliary pumps
  3. Switchboards
  4. Generators
- 6-61. When supply voltage has been restored, what type of motor controller will (a) automatically restart the motor and (b) require manual startup?
1. (a) High-voltage release  
(b) low-voltage protection
  2. (a) High-voltage release  
(b) high-voltage protection
  3. (a) Low-voltage release  
(b) low-voltage protection
  4. (a) Low-voltage release  
(b) high-voltage protection
- 6-62. You should protect batteries from salt water for which of the following reasons?
1. To prevent release of poisonous gases
  2. To prevent the battery from being ruined
  3. Both 1 and 2 above
- 6-63. In which of the following ways are the power and lighting distribution systems different?
1. The systems have different power sources
  2. The power distribution system carries higher voltage
  3. The power distribution system's cables are more numerous
  4. The lighting distribution systems have larger cables
- 6-64. As required by shipboard electric safety programs, all personally owned electrical equipment must be checked before being used aboard ship.
1. True
  2. False
- 6-65. Before repairs can be made to an electric motor, which of the following precautions must be met?
1. The controller must be tagged out
  2. The circuit must be disconnected
  3. Both 1 and 2 above
  4. The pump end of the motor must be disconnected
- 6-66. Heat stress is the body's inability to cope with a high-temperature and high-humidity environment. The term "heat stress" is a general term used to describe which of the following physical problems?
1. Heat cramps
  2. Heatstroke
  3. Heat exhaustion
  4. All of the above
- 6-67. What type of heat stress is life threatening?
1. Heat exhaustion
  2. Heat cramps
  3. Heatstroke
- 6-68. When administering first aid to a heatstroke victim, what step should you take first?
1. Lower the victim's body temperature
  2. Administer a salty, cool liquid
  3. Cover the victim with a blanket and elevate the head
  4. Cover the victim with a blanket and elevate the feet

6-69. You should NOT take which of the following actions when working in conditions that could cause heat stress?

1. Drink commercially prepared electrolyte supplements
2. Wear starched clothes
3. Take salt tablets
4. Each of the above

6-70. The ships Oil Spill Containment and Cleanup Kit (O.S.C.C.K.) consists of which of the following materials?

1. Porous mats, grappling hooks, boat hooks, metal containers, and a fire retardant
2. Porous mats, a chemical fire retardant, grappling hooks, plastic bags, and an instruction book
3. Porous mats, grappling hooks, boat hooks, plastic bags, and an instruction book
4. A chemical fire retardant, grappling hooks, plastic bags, porous mats, and an instruction book

6-71. Continued exposure to impulse or impact noise greater than 140 decibels can cause which of the following hearing losses?

1. Normal
2. Severe
3. Slight
4. Intermittent

6-72. Personnel who work with asbestos and smoke should be aware that their chances of contracting lung cancer are increased by which of the following rates?

1. Tenfold
2. Twentyfold
3. Fiftyfold
4. Ninetyfold

6-73. When work is being done on refrigeration systems, the area should be monitored with which of the following devices?

1. A low-pressure gauge
2. A flame safety lamp
3. A halide monitor
4. A TLV detector

6-74. To alleviate the detrimental effects of shipboard sewage on the environment, which of the following devices are installed on Navy ships?

1. High-concentration sewage devices
2. Chemical sanitation devices
3. Marine sanitation devices
4. Pier-side devices

6-75. Zero liquid discharge is a design feature of which of the following MSD systems?

1. LHA
2. Jered
3. LPA
4. Jiffy

